



SuperServer[®] 1029GP-TR



USER'S MANUAL

Revision 1.0b

The information in this User's Manual has been carefully reviewed and is believed to be accurate. The vendor assumes no responsibility for any inaccuracies that may be contained in this document, and makes no commitment to update or to keep current the information in this manual, or to notify any person or organization of the updates. **Please Note: For the most up-to-date version of this manual, please see our website at www.supermicro.com.**

Super Micro Computer, Inc. ("Supermicro") reserves the right to make changes to the product described in this manual at any time and without notice. This product, including software and documentation, is the property of Supermicro and/or its licensors, and is supplied only under a license. Any use or reproduction of this product is not allowed, except as expressly permitted by the terms of said license.

IN NO EVENT WILL Super Micro Computer, Inc. BE LIABLE FOR DIRECT, INDIRECT, SPECIAL, INCIDENTAL, SPECULATIVE OR CONSEQUENTIAL DAMAGES ARISING FROM THE USE OR INABILITY TO USE THIS PRODUCT OR DOCUMENTATION, EVEN IF ADVISED OF THE POSSIBILITY OF SUCH DAMAGES. IN PARTICULAR, SUPER MICRO COMPUTER, INC. SHALL NOT HAVE LIABILITY FOR ANY HARDWARE, SOFTWARE, OR DATA STORED OR USED WITH THE PRODUCT, INCLUDING THE COSTS OF REPAIRING, REPLACING, INTEGRATING, INSTALLING OR RECOVERING SUCH HARDWARE, SOFTWARE, OR DATA.

Any disputes arising between manufacturer and customer shall be governed by the laws of Santa Clara County in the State of California, USA. The State of California, County of Santa Clara shall be the exclusive venue for the resolution of any such disputes. Supermicro's total liability for all claims will not exceed the price paid for the hardware product.

FCC Statement: This equipment has been tested and found to comply with the limits for a Class A digital device pursuant to Part 15 of the FCC Rules. These limits are designed to provide reasonable protection against harmful interference when the equipment is operated in an industrial environment. This equipment generates, uses, and can radiate radio frequency energy and, if not installed and used in accordance with the manufacturer's instruction manual, may cause harmful interference with radio communications. Operation of this equipment in a residential area is likely to cause harmful interference, in which case you will be required to correct the interference at your own expense.

California Best Management Practices Regulations for Perchlorate Materials: This Perchlorate warning applies only to products containing CR (Manganese Dioxide) Lithium coin cells. "Perchlorate Material-special handling may apply. See www.dtsc.ca.gov/hazardouswaste/perchlorate".



WARNING: This product can expose you to chemicals including lead, known to the State of California to cause cancer and birth defects or other reproductive harm. For more information, go to www.P65Warnings.ca.gov.

The products sold by Supermicro are not intended for and will not be used in life support systems, medical equipment, nuclear facilities or systems, aircraft, aircraft devices, aircraft/emergency communication devices or other critical systems whose failure to perform be reasonably expected to result in significant injury or loss of life or catastrophic property damage. Accordingly, Supermicro disclaims any and all liability, and should buyer use or sell such products for use in such ultra-hazardous applications, it does so entirely at its own risk. Furthermore, buyer agrees to fully indemnify, defend and hold Supermicro harmless for and against any and all claims, demands, actions, litigation, and proceedings of any kind arising out of or related to such ultra-hazardous use or sale.

Manual Revision 1.0b

Release Date: April 28, 2020

Unless you request and receive written permission from Super Micro Computer, Inc., you may not copy any part of this document. Information in this document is subject to change without notice. Other products and companies referred to herein are trademarks or registered trademarks of their respective companies or mark holders.

Copyright © 2020 by Super Micro Computer, Inc.
All rights reserved.

Printed in the United States of America

Preface

About this Manual

This manual is written for professional system integrators and PC technicians. It provides information for the installation and use of the SuperServer 1029GP-TR. Installation and maintenance should be performed by experienced technicians only.

Please refer to the 1029GP-TR server specifications page on our website for updates on supported memory, processors and operating systems (<http://www.supermicro.com>).

Notes

For your system to work properly, please follow the links below to download all necessary drivers/utilities and the user's manual for your server.

- Supermicro product manuals: <http://www.supermicro.com/support/manuals/>
- Product drivers and utilities: <https://www.supermicro.com/wftp/driver>
- Product safety info: http://www.supermicro.com/about/policies/safety_information.cfm

If you have any questions, please contact our support team at:
support@supermicro.com

This manual may be periodically updated without notice. Please check the Supermicro website for possible updates to the manual revision level.

Secure Data Deletion

A secure data deletion tool designed to fully erase all data from storage devices can be found at our website: https://www.supermicro.com/about/policies/disclaimer.cfm?url=/wftp/utility/Lot9_Secure_Data_Deletion_Utility/

Warnings

Special attention should be given to the following symbols used in this manual.



Warning! Indicates important information given to prevent equipment/property damage or personal injury.



Warning! Indicates high voltage may be encountered when performing a procedure.

Contents

Chapter 1 Introduction

1.1 Overview.....	8
1.2 Unpacking the System	8
1.3 System Features	9
1.4 Server Chassis Features.....	10
Control Panel	10
Front Features.....	11
GPU Configuration	12
Rear Features	12
1.5 Motherboard Layout	13
Quick Reference Table.....	14

Chapter 2 Server Installation

2.1 Overview.....	17
2.2 Preparing for Setup.....	17
Choosing a Setup Location.....	17
Rack Precautions	17
Server Precautions.....	18
Rack Mounting Considerations	18
Ambient Operating Temperature.....	18
Airflow	18
Mechanical Loading.....	18
Circuit Overloading	19
Reliable Ground.....	19
2.3 Installing the Rails.....	20
Identifying the Sections of the Rack Rails	20
Assembling the Outer Rails	21
Installing the Outer Rails onto the Rack.....	22
Installing and Removing the Chassis From a Rack	23
Installing the Server into a Telco Rack	24

Chapter 3 Maintenance and Component Installation

3.1 Removing Power	25
3.2 Accessing the System.....	25
3.3 Motherboard Components.....	26

Processor and Heatsink Installation.....	26
Assembling the Processor Package.....	27
Removing the Dust Cover from the CPU Socket.....	29
Installing the Processor Heatsink Module (PHM)	30
Removing the Processor Heatsink Module from the Motherboard	31
Memory Installation	32
Memory Support	32
Motherboard Battery	36
3.4 Chassis Components	37
Hard Drives	37
Externally Accessible Drives.....	37
Hot-Swap for NVMe Drives	38
Checking the Temperature of an NVMe Drive	39
Installing GPUs	40
Installing Expansion Cards	41
System Cooling	42
System Fan Failure	43
Installing the Air Shroud.....	44
Power Supply	45
Chapter 4 Motherboard Connections	
4.1 Power Connections	46
4.2 Headers and Connectors	47
Control Panel.....	49
4.3 Ports	52
Rear I/O Ports.....	52
4.4 Jumpers.....	54
Explanation of Jumpers	54
4.5 LED Indicators.....	57
Chapter 5 Software	
5.1 Microsoft Windows OS Installation.....	58
5.2 Driver Installation.....	60
5.3 SuperDoctor® 5.....	61
5.4 IPMI	62

Chapter 6 BIOS

6.1 Introduction	63
Starting the Setup Utility	63
6.2 Main Setup	64
6.3 Advanced Setup Configurations	66
6.4 Event Logs	91
6.5 IPMI	93
6.6 Security Settings	96
6.7 Boot Settings	99
6.8 Save & Exit.....	101

Appendix A BIOS Error Codes**Appendix B Standardized Warning Statements for AC Systems****Appendix C System Specifications****Appendix D CPU-Based RAID for NVMe**

Contacting Supermicro

Headquarters

Address: Super Micro Computer, Inc.
980 Rock Ave.
San Jose, CA 95131 U.S.A.

Tel: +1 (408) 503-8000

Fax: +1 (408) 503-8008

Email: marketing@supermicro.com (General Information)
support@supermicro.com (Technical Support)

Website: www.supermicro.com

Europe

Address: Super Micro Computer B.V.
Het Sterrenbeeld 28, 5215 ML
's-Hertogenbosch, The Netherlands

Tel: +31 (0) 73-6400390

Fax: +31 (0) 73-6416525

Email: sales@supermicro.nl (General Information)
support@supermicro.nl (Technical Support)
rma@supermicro.nl (Customer Support)

Website: www.supermicro.nl

Asia-Pacific

Address: Super Micro Computer, Inc.
3F, No. 150, Jian 1st Rd.
Zhonghe Dist., New Taipei City 235
Taiwan (R.O.C)

Tel: +886-(2) 8226-3990

Fax: +886-(2) 8226-3992

Email: support@supermicro.com.tw

Website: www.supermicro.com.tw

Chapter 1

Introduction

1.1 Overview

This chapter provides a brief outline of the functions and features of the SuperServer 1029GP-TR. The 1029GP-TR is a high-end GPU (graphics processing unit) system comprised of the X11DPG-SN motherboard and the SC118GHTS-R1K66BP2 chassis.

In addition to the motherboard and chassis, several important parts that are included with the system are listed below.

Main Parts List		
Description	Part Number	Quantity
Air Shroud	MCP-310-11810-0B	1
Heatsink (for CPU1)	SNK-P0067PS	1
Heatsink (for CPU2)	SNK-P0067PSMB	1
Fans (4-cm)	FAN-0141L4	10
Hot-swap Carriers (for 2.5" HDDs)	MCP-220-00047-0B	4
HDD Backplane	BPN-SAS3-118GH-N2	1
Rackmount Rail Kit	MCP-290-00054-0N	1 set

Riser Card Support		
Riser Card	Supports	Location
RSC-R1UG-E16-X9	Left GPU riser with one PCI-E x16 slot	Slot 1
RSC-R1UG-E16AR+II	Right GPU riser with one PCI-E x16 slot	Slot 2
RSC-G-A66-X	Rear GPU or AOC riser with two PCI-E x16 slots	Slot 3 & 4
RSC-R1UG-E16R+II	Low profile AOC riser with one PCI-E x8 slot (in a PCI-E x16 slot)	Slot 5

1.2 Unpacking the System

Inspect the box the SuperServer 1029GP-TR was shipped in and note if it was damaged in any way. If any equipment appears damaged, please file a damage claim with the carrier who delivered it.

Decide on a suitable location for the rack unit that will hold the server. It should be situated in a clean, dust-free area that is well ventilated. Avoid areas where heat, electrical noise and electromagnetic fields are generated. It will also require a grounded AC power outlet nearby. Be sure to read the precautions and considerations noted in Appendix B.

1.3 System Features

The following table provides you with an overview of the main features of the 1029GP-TR. Please refer to Appendix C for additional specifications.

System Features
Motherboard
X11DPG-SN
Chassis
SC118GHTS-R1K66BP2
CPU
Dual Intel Xeon 81xx/61xx/51xx/41xx/31xx series or 82xx/62xx/52xx/42xx/32xx series processors
Socket Type
Socket P
Memory
Up to 4TB of DDR4-2933/2666/2400/2133 3DS Load Reduced DIMM (3DS LRDIMM), Load Reduced DIMM (LRDIMM), Registered DIMM (RDIMM), or Non-Volatile DIMM (NVDIMM) in 16 DIMM slots
Chipset
Intel PCH C621
Expansion Slots
Up to five PCI-E 3.0 slots (see table on page 12 for details)
Drive Bays
Four bays support 2.5" SAS/SATA3 drives, two of these can also support NVMe drives (all are hot-swap)
Power
1600W redundant power supply modules (PWS-1K66P-1R)
Form Factor
1U rackmount
Dimensions
(WxHxD) 17.2 x 1.7 x 30.6 in. (437 x 43 x 777 mm)

1.4 Server Chassis Features

Control Panel

The switches and LEDs located on the control panel are described below. See Chapter 4 for details on the control panel connections.

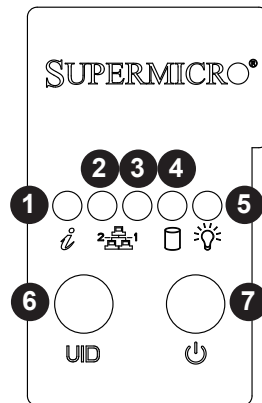

Figure 1-1. Control Panel View

Control Panel Features		
Item	Feature	Description
1	Information LED	See table below
2	NIC2 LED	Indicates network activity on the LAN2 port when flashing
3	NIC1 LED	Indicates network activity on the LAN1 port when flashing
4	HDD LED	Indicates activity on the hard drive when flashing
5	Power LED	Indicates power is being supplied to the system power supply units. This LED should normally be illuminated when the system is operating.
6	UID LED	The unit identification (UID) button turns on or off the blue light function of the Information LED and the blue LED on the rear of the chassis. These are used to locate the server in large racks and server banks.
7	Power Button	The main power button is used to apply or remove power from the power supply to the server. Turning off system power with this button removes the main power but maintains standby power. To perform many maintenance tasks, you must also unplug system before servicing

Information LED	
Status	Description
Continuously on and red	An overheat condition has occurred. (This may be caused by cable congestion.)
Blinking red (1Hz)	Fan failure, check for an inoperative fan.
Solid blue	UID has been activated locally to locate the server in a rack environment.
Blinking blue	UID has been activated using IPMI to locate the server in a rack environment.

Front Features

The SC118GHTS-R1K66BP2 is a 1U rackmount chassis. See the illustration below for the features included on the front of the chassis. The drive bays support SATA3, SAS or two NVMe drives. See the bottom figure for NVMe drive locations.



Front Chassis Features		
Item	Feature	Description
0* ~ 3*	Drive Bay	2.5" hot-swap drive bay (supports SATA3 or SAS drives with optional SAS HBA)
4	Control Panel	See previous page for details.

*Number indicates logical drive location.

Figure 1-2. Chassis Front View



NVMe Drive Bays		
Item	Feature	Description
0*	Drive Bay	2.5" hot-swap drive bay supports NVMe U.2 drives
1*	Drive Bay	2.5" hot-swap drive bay supports NVMe U.2 drives

*Number indicates logical drive location.

Figure 1-3. Chassis Front View (with NVMe Drives)

Rear Features

The illustration below shows the features included on the rear of the chassis.

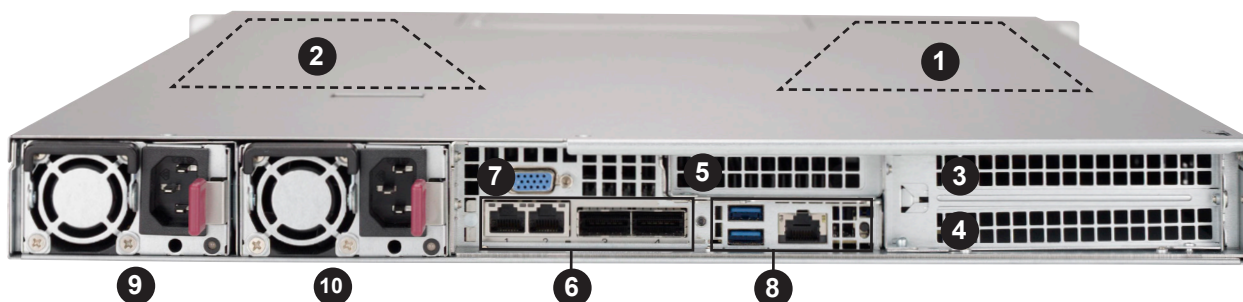

Figure 1-4. Chassis Rear View

Rear Chassis Features			
Item	Feature	Location	Description
1	GPU Slot	Slot 1 (internal)	Double-width passive GPU or single-width passive GPU (CPU1). RSC-R1UG-E16-X9 riser supports PCI-E Gen 3.0 x16
2	GPU Slot	Slot 2 (internal)	Double-width passive GPU or single-width passive GPU (CPU2). RSC-R1UG-E16AR+II riser supports PCI-E Gen 3.0 x16
3	GPU or AOC Slot	Slot 3 (upper)	Double-width passive GPU, single-width passive GPU, or FHFL AOC (CPU2). RSC-G-A66-X riser supports PCI-E Gen 3.0 x16 AOC.
4	GPU or AOC Slot	Slot 4 (lower)	Single-width passive GPU if slot 3 also single-width, or FHFL AOC (CPU1). RSC-G-A66-X riser supports PCI-E Gen 3.0 x16 AOC
5	AOC LP Slot	Slot 5	LP AOC (CPU2). RSC-R1UG-E16R+II riser supports Gen 3.0 x8 (in x16)
6	SIOM Networking	SIOM Slot	Directly attached to motherboard. There are many flexible options for this add-on card. Check Supermicro's website for more details. (CPU1)
7	VGA Port	n/a	See Section 4.3 for details.
8	I/O Ports	n/a	See Section 4.3 for details.
9	PSU1	n/a	Redundant 1600W power supply module (PWS-1K66P-1R)
10	PSU2	n/a	Redundant 1600W power supply module (PWS-1K66P-1R)

GPU: Graphics Processing Unit

AOC: Add-on Card

SIOM: Super I/O Module

GPU Configuration

The 1029GP-TR offers four PCI-E x16 slots and one LP PCI-E x8 (in a x16 slot). Two of the x16 slots located in the front can support two double-width passive GPUs. There are two PCI-E x16 and one PCI-E x8 slots in the rear that can support either a double-width passive GPU plus one standard LP AOC or three standard AOCs.

1.5 Motherboard Layout

Below is a layout of the X11DPG-SN with jumper, connector and LED locations shown. See the table on the following page for descriptions. For detailed descriptions, pinout information and jumper settings, refer to Chapter 4.

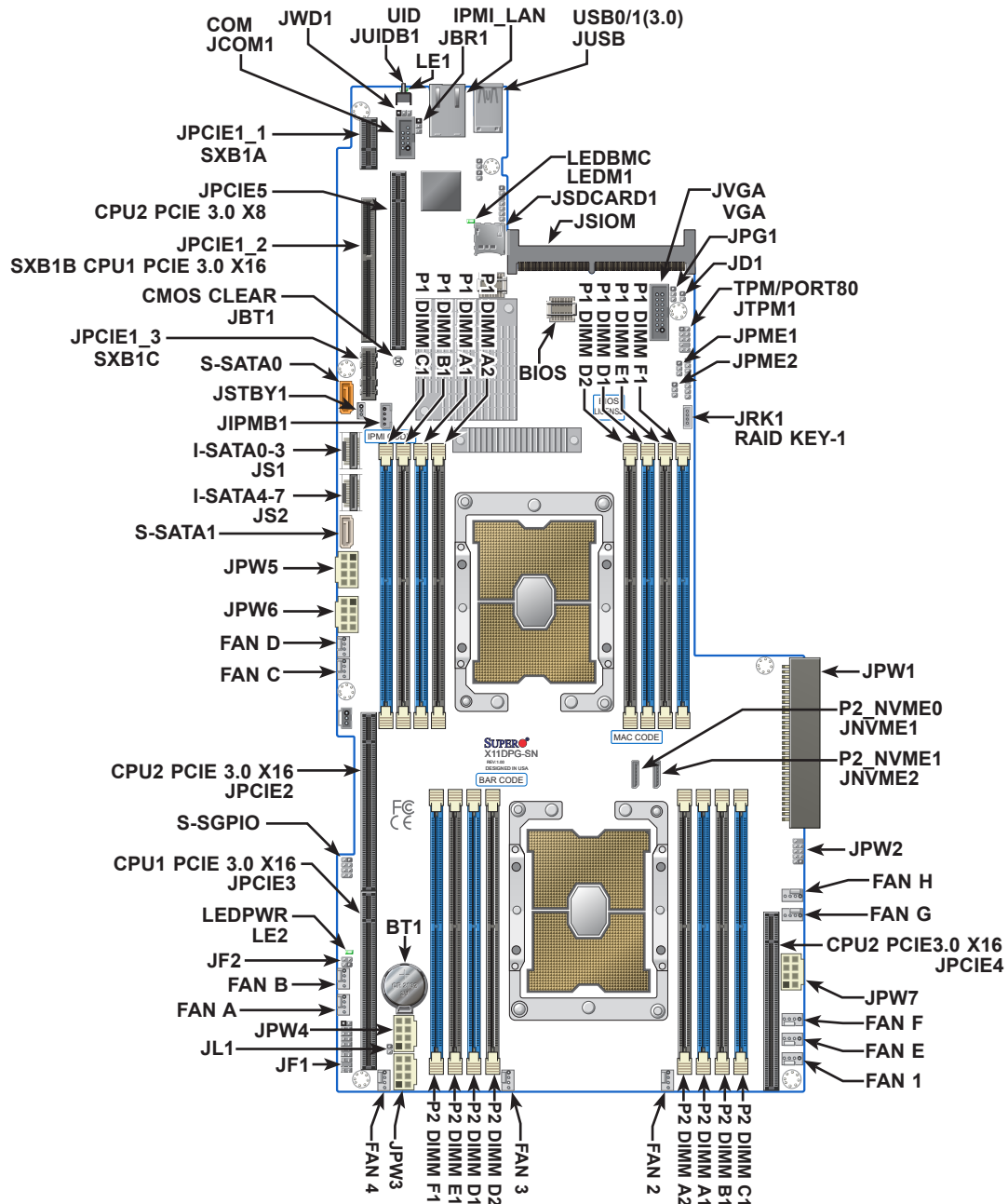

Figure 1-5. Motherboard Layout

Notes:

- Jumpers/LED indicators not indicated are used for testing only.
- "■" indicates the location of pin 1.

Quick Reference Table

Jumper	Description	Default Setting
JBT1	CMOS Clear	Open (Normal)
JPG1	VGA Enable/Disable	Pins 1-2 (Enabled)
JPME1	ME Recovery Mode	Pins 1-2 (Normal)
JPME2	ME Manufacturing Mode	Pins 1-2 (Normal)
JWD1	Watch Dog	Pins 1-2 (Reset)

LED	Description	Status
LE1	UID LED	Solid Blue: Unit Identified
LE2	Front Panel Power LED	Green: Power On
LEDM1	BMC Heartbeat LED	Blinking Green: BMC Normal

Connector	Description
BIOS	BIOS
BT1	Onboard Battery
FAN 1 ~ FAN 4	System/CPU Fan Headers (FAN1: CPU Fan)
FAN A ~ FAN H	System/CPU Fan Headers
IPMI_LAN	Dedicated IPMI LAN Port
I-SATA0~3 / JS1	Intel PCH SATA 3.0 Ports
I-SATA1~4 / JS2	Intel PCH SATA 3.0 Ports
JCOM1	COM Port
JD1	Speaker Header
JF1	Front Control Panel Header
JF2	Front Panel LAN3 and LAN4 Activity LEDs from SIOM
JIPMB1	System Management Bus Header for IPMI 2.0
JL1	Chassis Intrusion Header
JNVME1, JNVME2	P2_NVMe0, P2_NVMe1; Onboard NVMe 0 and 1 for high speed PCI-E storage devices on CPU2
JPCIE1_1 SXB1A	Supermicro Proprietary Slot1
JPCIE1_2 SXB1B	PCI-Express 3.0 x16 Slot from CPU1
JPCIE1_3 SXB1C	Supermicro Proprietary Slot1
JPCIE2	PCI-Express 3.0 x16 Slot from CPU2
JPCIE3	PCI-Express 3.0 x16 Slot from CPU1
JPCIE4	PCI-Express 3.0 x16 Slot from CPU2
JPCIE 5	PCI-Express 3.0 x8 Slot from CPU2
JPW1	Supermicro Proprietary Main Power Connector
JPW2	Power Supply Sideband Connector
JPW3 - JPW7	Backplane Power Connectors for HDDs and GPUs

Connector	Description
JRK1	Intel Raid Key Header
JSDCARD1	SD Card Socket
JSIOM	PCI-Express 3.0 x16 slot from CPU1 for Supermicro SIOM add-on Module Support
JSTBY1	Standby Power Connector
JTPM1 TPM/PORT80	Trusted Platform Module/Port 80 Connector
JUIDB1 / UID	Unit Identifier (UID) Switch
JUSB / USB0/1 (3.0)	Back Panel Universal Serial Bus (USB) 3.0 Port
JVGA / VGA	VGA Header
S-SATA0	Intel PCH SATA 3.0 Port
S-SATA1	Intel PCH SATA 3.0 Port
S-SGPIO1	Serial Link General Purpose Input/Output Header 1 for S-SATA ports

Chapter 2

Server Installation

2.1 Overview

This chapter provides advice and instructions for mounting your system in a server rack. If your system is not already fully integrated with processors, system memory etc., refer to Chapter 4 for details on installing those specific components.

Caution: Electrostatic Discharge (ESD) can damage electronic components. To prevent such damage to PCBs (printed circuit boards), it is important to use a grounded wrist strap, handle all PCBs by their edges and keep them in anti-static bags when not in use.

2.2 Preparing for Setup

The box in which the system was shipped should include the rackmount hardware needed to install it into the rack. Please read this section in its entirety before you begin the installation.

Choosing a Setup Location

- The system should be situated in a clean, dust-free area that is well ventilated. Avoid areas where heat, electrical noise and electromagnetic fields are generated.
- Leave enough clearance in front of the rack so that you can open the front door completely (~25 inches) and approximately 30 inches of clearance in the back of the rack to allow sufficient space for airflow and access when servicing.
- This product should be installed only in a Restricted Access Location (dedicated equipment rooms, service closets, etc.).
- This product is not suitable for use with visual display workplace devices according to §2 of the German Ordinance for Work with Visual Display Units.

Rack Precautions

- Ensure that the leveling jacks on the bottom of the rack are extended to the floor so that the full weight of the rack rests on them.

- In single rack installations, stabilizers should be attached to the rack. In multiple rack installations, the racks should be coupled together.
- Always make sure the rack is stable before extending a server or other component from the rack.
- You should extend only one server or component at a time - extending two or more simultaneously may cause the rack to become unstable.

Server Precautions

- Review the electrical and general safety precautions in Appendix B.
- Determine the placement of each component in the rack *before* you install the rails.
- Install the heaviest server components at the bottom of the rack first and then work your way up.
- Use a regulating uninterruptible power supply (UPS) to protect the server from power surges and voltage spikes and to keep your system operating in case of a power failure.
- Allow any drives and power supply modules to cool before touching them.
- When not servicing, always keep the front door of the rack and all covers/panels on the servers closed to maintain proper cooling.

Rack Mounting Considerations

Ambient Operating Temperature

If installed in a closed or multi-unit rack assembly, the ambient operating temperature of the rack environment may be greater than the room's ambient temperature. Therefore, consideration should be given to installing the equipment in an environment compatible with the manufacturer's maximum rated ambient temperature (TMRA).

Airflow

Equipment should be mounted into a rack so that the amount of airflow required for safe operation is not compromised.

Mechanical Loading

Equipment should be mounted into a rack so that a hazardous condition does not arise due to uneven mechanical loading.

Circuit Overloading

Consideration should be given to the connection of the equipment to the power supply circuitry and the effect that any possible overloading of circuits might have on overcurrent protection and power supply wiring. Appropriate consideration of equipment nameplate ratings should be used when addressing this concern.

Reliable Ground

A reliable ground must be maintained at all times. To ensure this, the rack itself should be grounded. Particular attention should be given to power supply connections other than the direct connections to the branch circuit (i.e. the use of power strips, etc.).



To prevent bodily injury when mounting or servicing this unit in a rack, you must take special precautions to ensure that the system remains stable. The following guidelines are provided to ensure your safety:

- This unit should be mounted at the bottom of the rack if it is the only unit in the rack.
- When mounting this unit in a partially filled rack, load the rack from the bottom to the top with the heaviest component at the bottom of the rack.
- If the rack is provided with stabilizing devices, install the stabilizers before mounting or servicing the unit in the rack.

2.3 Installing the Rails

This section provides information on installing the chassis into a rack unit with the rails provided. There are a variety of rack units on the market, which may mean that the assembly procedure will differ slightly from the instructions provided. You should also refer to the installation instructions that came with the rack unit you are using.

Note: This rail will fit a rack between 27" and 32" deep.

Identifying the Sections of the Rack Rails

The chassis package includes two sets of rack rails, one set for the right side of the chassis and one for the left.

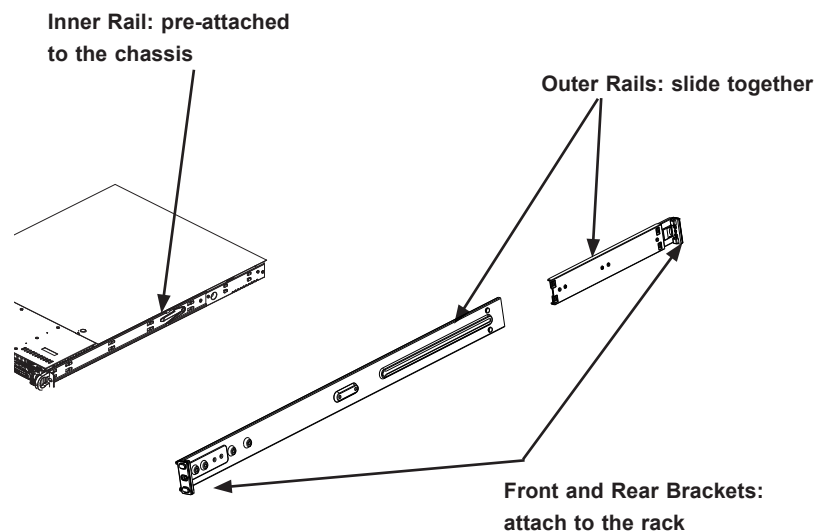

Figure 2-1. Identifying the Rail Sections



Warning: Stability hazard. The rack stabilizing mechanism must be in place, or the rack must be bolted to the floor before you slide the unit out for servicing. Failure to stabilize the rack can cause the rack to tip over.

Assembling the Outer Rails

Each outer rail comes in two sections that must be assembled before mounting onto the rack.

Assembling the Outer Rails

1. Identify the left and right outer rails by examining the ends, which bend outward. Match the left front outer rail with the left rear outer rail and the same for the right rails.
2. Align the round post in the rear rail (B) with the round hole at the end of the slot in the front rail (A), and slide the front section into the rear section.

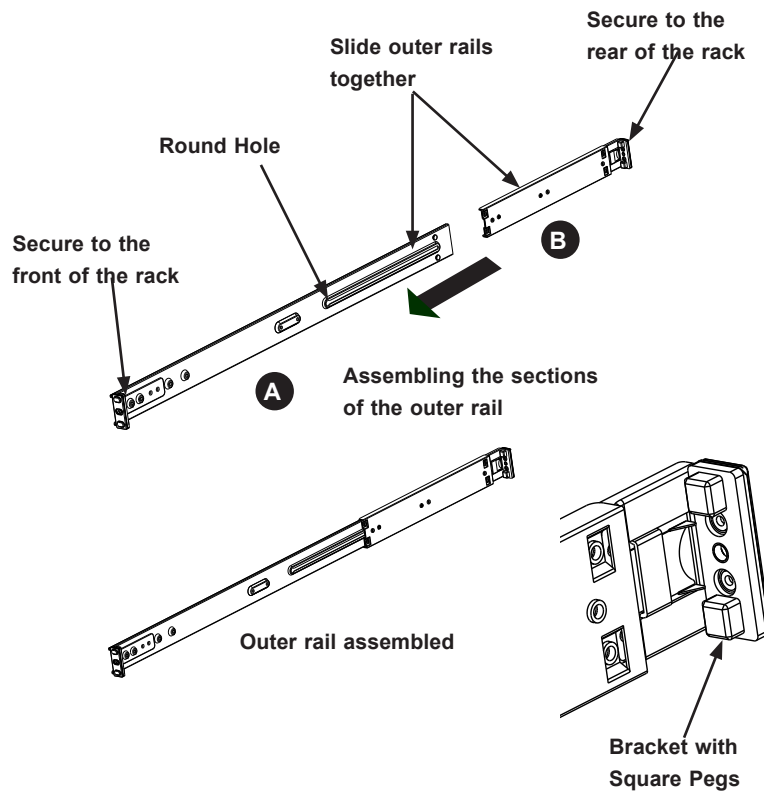

Figure 2-2. Assembling the Outer Rails



Slide rail mounted equipment is not to be used as a shelf or a work space.



Warning: do not pick up the server with the front handles. They are designed to pull the system from a rack only.

Installing the Outer Rails onto the Rack

Each end of the assembled outer rail includes a bracket with square pegs to fit into your rack holes. If you have an older rack with round holes, these brackets must be removed, and you must use screws to secure the rail to the rack.

Installing the Outer Rails

1. Align the square pegs on the front end of the rail with the square holes on the front of the rack (C). Push the rail into the rack until the quick release bracket snaps into place, securing the rail to the rack. Keep the rail horizontal.
2. Adjust the rail to reach just past the full depth of your rack.
3. Align the square pegs on the rear end of the rail to the holes on the rack (D) and push the rail into the rack until the quick release bracket snaps into place, securing the rail to the rack.
4. Repeat the procedure for the other outer rail assembly.

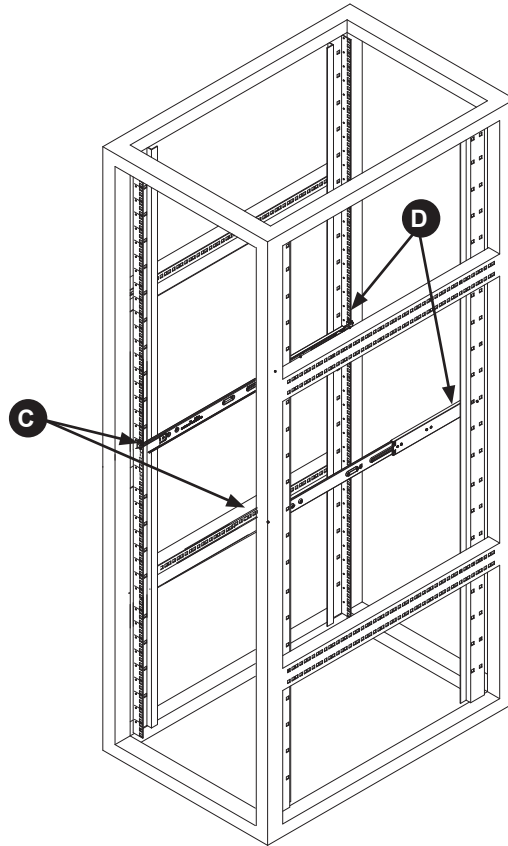

Figure 2-3. Installing the Outer Rails

Note: Figure is for illustrative purposes only. Always install servers to the bottom of a rack first.

Installing and Removing the Chassis From a Rack

Installing the Chassis into a Rack

1. Slide the inner rail into the front of the outer rails.
2. Push the chassis backward into the rack until it clicks into the locked position.

Removing the Chassis From a Rack

1. Press the outer rail latch to release the chassis.
2. Carefully slide the chassis forward, off the outer rails and out of the chassis.

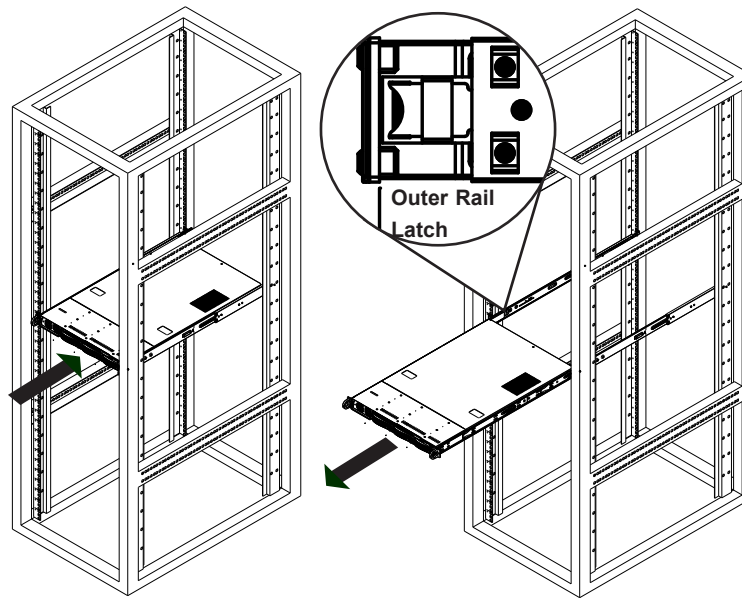

Figure 2-4. Installing and Removing the System from a Rack

Note: Figure is for illustrative purposes only. Always install servers to the bottom of a rack first.

Installing the Server into a Telco Rack

Optional brackets are needed to install the server to a telco (open type) rack.

To install the server into a Telco type rack, use the two L-shaped brackets on either side of the chassis (four total).

1. Determine how far forward the server will extend out the front of the rack. Larger chassis should be positioned to balance the weight between front and back.
2. If a bezel is included on your server, remove it.
3. Attach the two front brackets to each side of the chassis, then the two rear brackets positioned with just enough space to accommodate the width of the telco rack.
4. Finish by sliding the chassis into the rack and tightening the brackets to the rack.

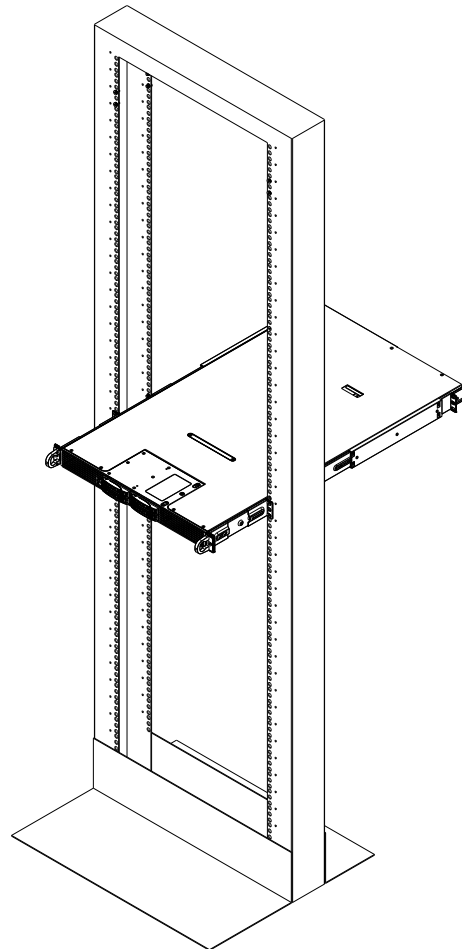

Figure 2-5. Installing the System into a Telco Rack

Note: Figure is for illustrative purposes only. Always install servers to the bottom of a rack first.

Chapter 3

Maintenance and Component Installation

This chapter provides instructions on installing and replacing main system components. To prevent compatibility issues, only use components that match the specifications and/or part numbers given.

Installation or replacement of most components require that power first be removed from the system. Please follow the procedures given in each section.

3.1 Removing Power

Use the following procedure to ensure that power has been removed from the system. This step is necessary when removing or installing non hot-swap components or when replacing a non-redundant power supply.

1. Use the operating system to power down the system.
2. After the system has completely shut-down, disconnect the AC power cord(s) from the power strip or outlet. (If your system has more than one power supply, remove the AC power cords from all power supply modules.)
3. Disconnect the power cord(s) from the power supply module(s).

3.2 Accessing the System

The SC118GHTS-R1K66BP2 features a removable top cover, which allows easy access to the inside of the chassis.

Removing the Top Cover

1. Begin by removing power from the system as described in Section 3.1.
2. Grasp the two handles on either side and pull the unit straight out until it locks (you will hear a "click").
3. Remove the screws securing the cover to the chassis.
4. Pull the cover towards the end of the chassis and off. See Figure 3-1.

Warning: Except for short periods of time, do not operate the server without the cover in place. The chassis cover must be in place to allow for proper airflow and to prevent overheating.

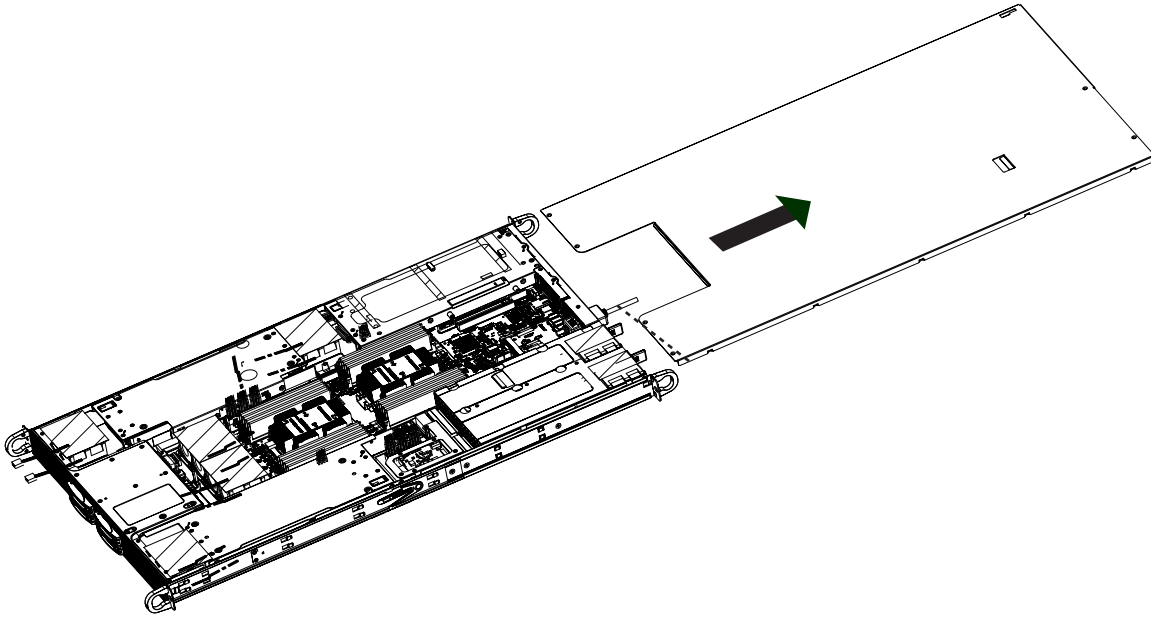

Figure 3-1. Removing the Chassis Cover

3.3 Motherboard Components

Processor and Heatsink Installation

The Intel Xeon 81xx/61xx/51xx/41xx/31xx/82xx/62xx/52xx/42xx/32xx series processors comes in two models: Fabric (F model) and Non-Fabric (Non-F model). Only the Non-Fabric model is supported for this system.

The processor (CPU) and heatsink should be assembled together first to form the processor heatsink module (PHM), and then install the PHM into the CPU socket.

Caution: Use ESD protection. Do not touch the underside of the CPU. Improper installation or socket misalignment can cause serious damage to the CPU or socket which may require manufacturer repairs.

Notes:

- All power should be off, as described in Section 3.1, before installing the processors.
- When handling the processor package, avoid placing direct pressure on the label area of the CPU or socket.
- Check that the plastic socket dust cover is in place and none of the socket pins are bent—otherwise, contact your retailer.
- Refer to the Supermicro website for updates on CPU support.
- Graphics in this manual are for illustration. Your components may look slightly different.

Assembling the Processor Package

Attach the processor to the thin processor clip to create the processor package.

1. On the top corner of the CPU, locate pin 1 (A), marked by a triangle. Also, locate notch B and notch C (and notch D for F models) on the CPU as shown below.
2. On the top of the processor clip, locate the corner marked by a hollow triangle as the position for pin 1. Also locate notch B and notch C (and D for F models) on the processor clip.
3. Align pin 1 of the CPU with its proper position on the processor clip and carefully insert the CPU into the processor clip. Slide notch B of the CPU into tab B of the processor clip, and slide notch C of the CPU into tab C of the processor clip (and D for F models) until the processor clip tabs snap onto the CPU.
4. Examine all corners to ensure that the CPU is properly seated and secure on the processor clip.

The processor package assembly is created.

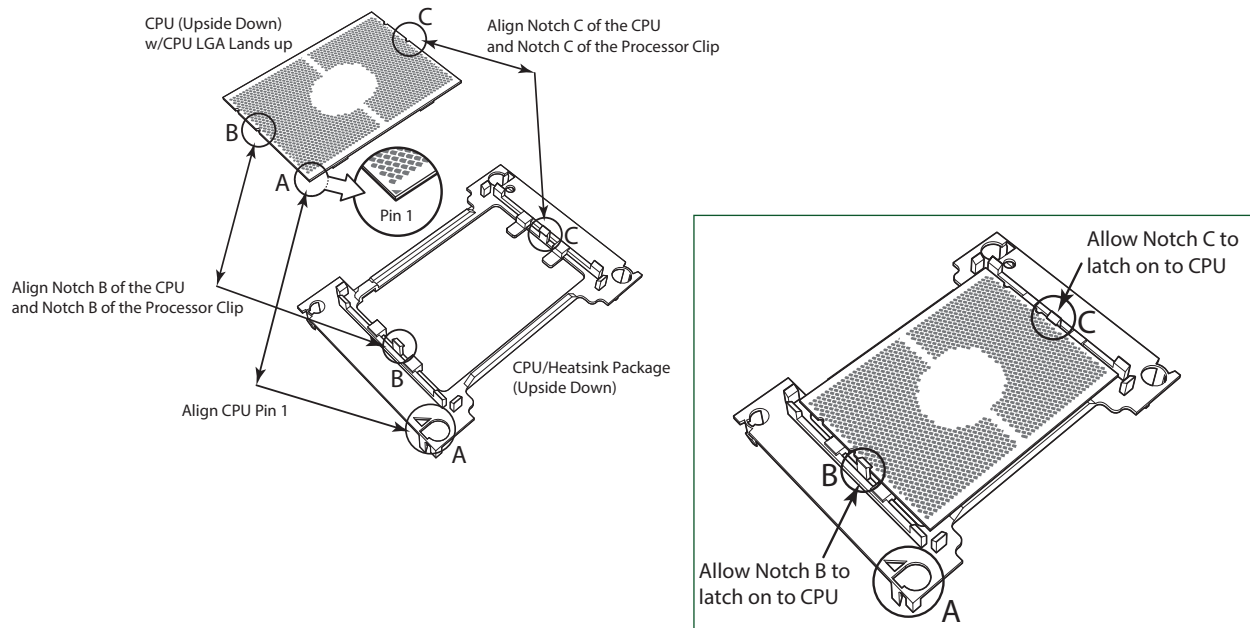

Figure 3-2. Processor Package Assembly for the Processors

After creating the processor package assembly, mount it onto the heatsink to create the processor heatsink module (PHM).

1. On the heatsink label, locate "1" and the corner next to it. Turn the heatsink upside down with the thermal grease side facing up, keeping track of the "1" corner.
2. Remove the protective thermal film if present. If this is a new heatsink, the necessary thermal grease has been pre-applied in the factory. If the heatsink is not new, apply the proper amount of the thermal grease.
3. In the plastic processor clip, locate the hollow triangle at the corner ("a" in the drawing below) next to a hole and plastic mounting clips. There is a similar hole and mounting clips at the diagonal corner of the of the processor clip ("b" in the drawing).
4. With the underside of heatsink and the underside of the processor package facing up, align the "1" corner on the heatsink ("A" in the drawing) against the mounting clips next to the hollow triangle ("a") on the processor package.
5. Also align the corner ("B") at the diagonal side of the heatsink with the corresponding clips on the processor package ("b").
6. Once aligned, press the processor package assembly onto the heatsink until the mounting clips (at a, b, c, and d) snap into place.

The processor heatsink module is assembled.

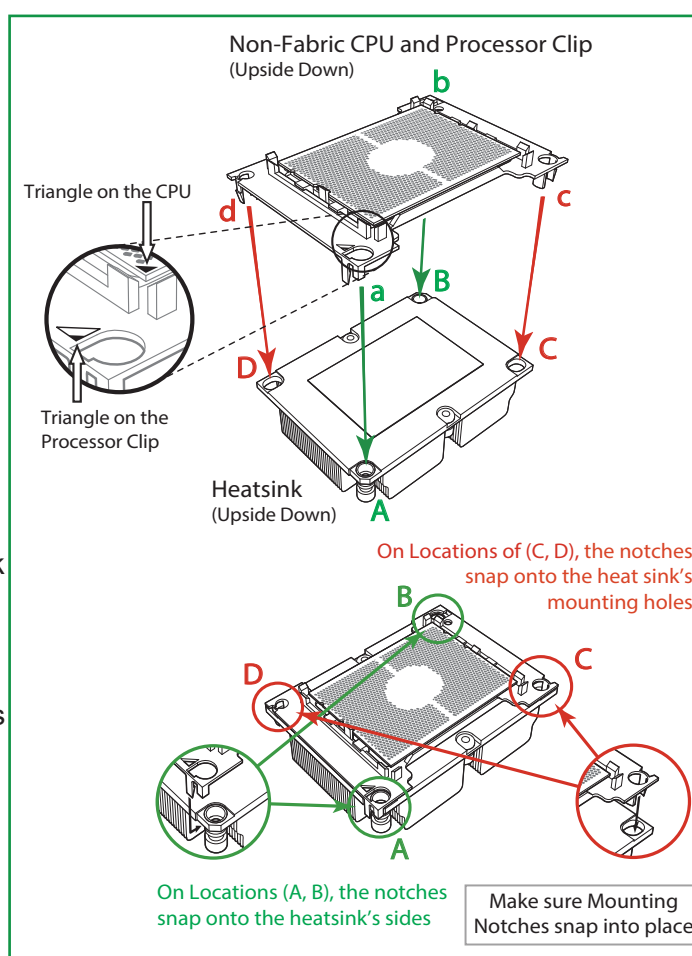

Figure 3-3. Assembling the Processor Heatsink Module

Removing the Dust Cover from the CPU Socket

Remove the dust cover from the CPU socket, exposing the socket pins as shown below.

Caution: Do not touch the socket pins.

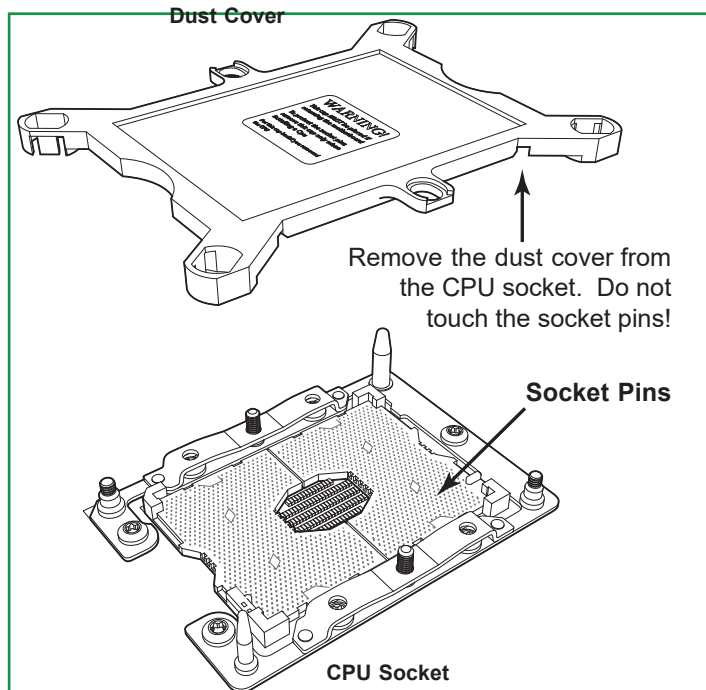

Figure 3-4. Removing the Socket Dust Cover

Installing the Processor Heatsink Module (PHM)

1. Locate the triangle (pin 1) on the CPU socket. Also locate the pin 1 corner of the PHM that is closest to "1" on the heatsink label. To confirm, look at the underside of the PHM and note the hollow triangle in the processor clip and printed triangle on the CPU located next to a screw at the corner.
2. Align the pin 1 corner of the PHM over the pin 1 corner on the CPU socket.
3. Align the two holes at diagonal corners of the PHM onto the two guide posts on the socket bracket and carefully lower the PHM onto the socket.
4. Use a T30 Torx-bit screwdriver to install four screws into the mounting holes on the socket to securely attach the PHM onto the motherboard in the sequence of 1, 2, 3, and 4, as marked on the heatsink label. Gradually tighten each to assure even pressure.

Note: Use only 12 foot-pounds of torque when tightening the screws to avoid damaging the processor or the socket.

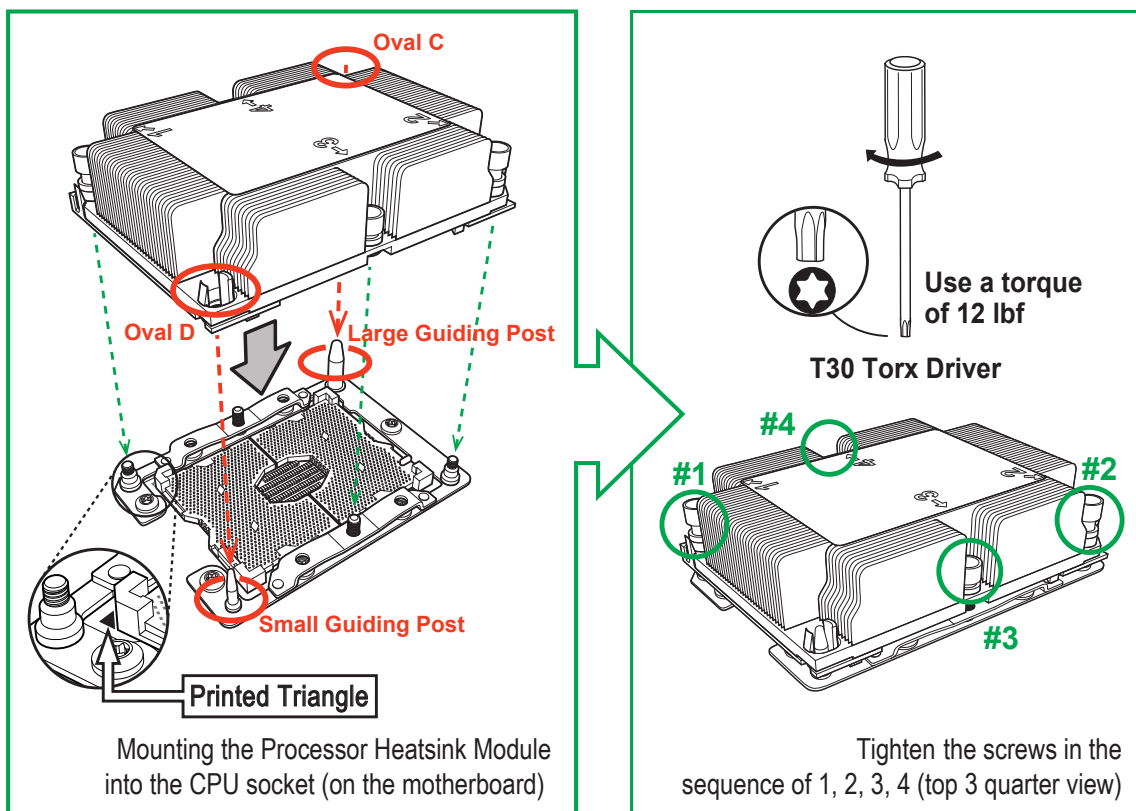

Figure 3-5. Installing the Processor Heatsink Module

Removing the Processor Heatsink Module from the Motherboard

Before removing the processor heatsink module (PHM), power down as described in Section 3.1.

1. Using a T30 Torx-bit screwdriver, loosen and remove the screws on the PHM from the socket, starting with the screw marked #4, in the sequence of 4, 3, 2, 1.
2. Pull up the PHM while releasing the small snap tabs on two corners of the socket.

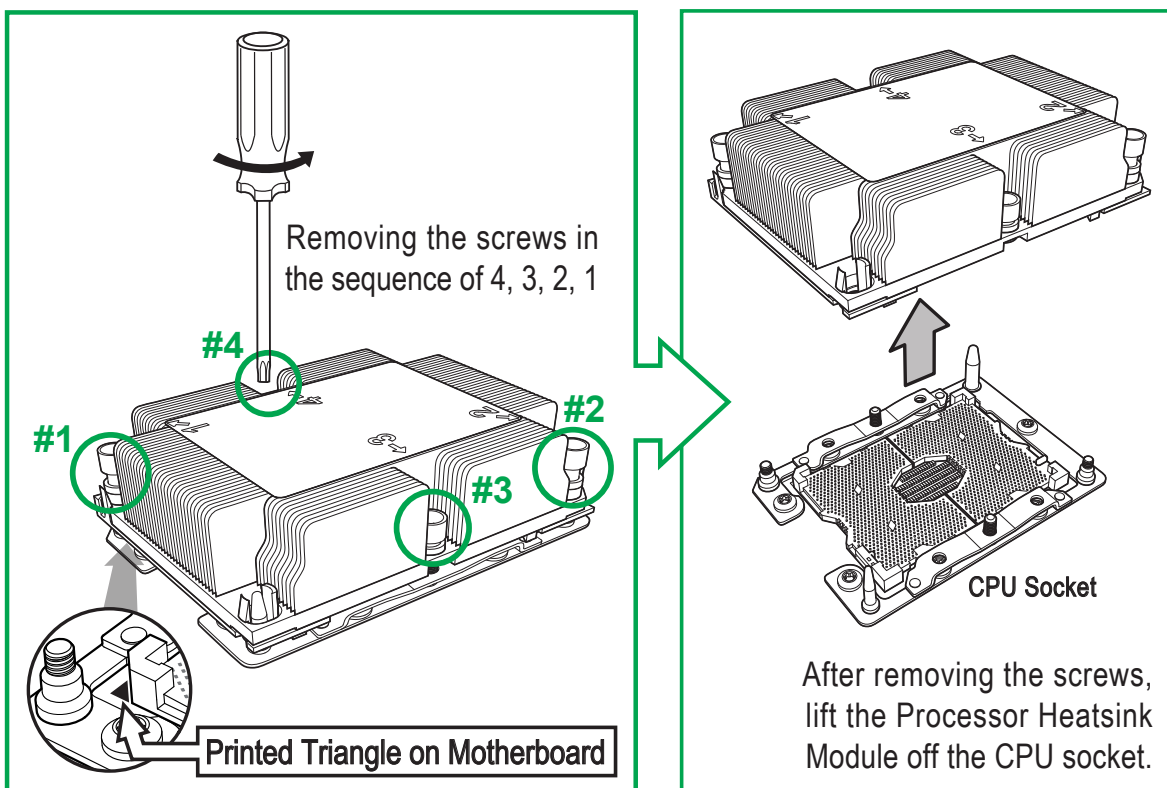

Figure 3-6. Removing the Processor Heatsink Module

Memory Installation

Memory Support

The X11DPG-SN supports up to 4TB of DDR4-2933/2666/2400/2133 3DS LRDIMM, LRDIMM, RDIMM, or NVDIMM in 16 DIMM slots. **Note:** 2933 MHz memory is supported by the 82xx/62xx platform only. Only Platinum-level and Gold-level processors support Intel Optane™ DC Persistent Memory Module (DCPMM).

Installing Memory

Begin by removing power from the system as described in Section 3.1.

1. Insert DIMM modules in the order as shown on the table on page 33. For the system to work properly, please use memory modules of the same type and speed.
2. Push the release tabs outwards on both ends of the DIMM slot to unlock it.
3. Align the key of the DIMM module with the receptive point on the memory slot.
4. Align the notches on both ends of the module against the receptive points on the ends of the slot.
5. Use two thumbs together to press both ends of the module straight down into the slot until the module snaps into place.
6. Press the release tabs to the lock positions to secure the DIMM module into the slot.

DIMM Removal

Reverse the steps above to remove the DIMM modules from the motherboard.

Caution: Exercise extreme caution when installing or removing memory modules to prevent any possible damage to the DIMMs or slots.

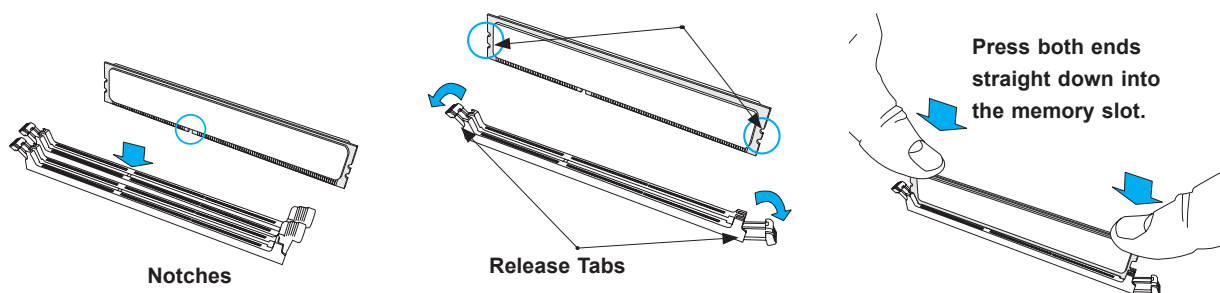

Figure 3-7. Installing DIMMs

Caution: In single-CPU configurations, memory must be installed in the DIMM slots associated with the installed CPU.

Note: Visit the product page on the Supermicro website for possible updates to memory support (www.supermicro.com).

Memory Population Table w/16 DIMM Slots Onboard	
CPUs/DIMMs	Memory Population Sequence
1 CPU & 1 DIMM	CPU1: P1-DIMMA1
1 CPU & 2 DIMMs	CPU1: P1-DIMMA1/P1-DIMMD1
1 CPU & 3 DIMMs	CPU1: P1-DIMMC1/P1-DIMMB1/P1-DIMMA1
1 CPU & 4 DIMMs	CPU1: P1-DIMMB1/P1-DIMMA1/P1-DIMMD1/P1-DIMME1
1 CPU & 5 DIMMs*	CPU1: P1-DIMMC1/P1-DIMMB1/P1-DIMMA1/P1-DIMMD1/P1-DIMME1
1 CPU & 6 DIMM	CPU1: P1-DIMMC1/P1-DIMMB1/P1-DIMMA1/P1-DIMMD1/P1-DIMME1/P1-DIMMF1
1 CPU & 7 DIMMs*	CPU1:P1-DIMMC1/P1-DIMMB1/P1-DIMMA1/P1-DIMMA2/P1-DIMMD1/P1-DIMME1/P1-DIMMF1
1 CPU & 8 DIMMs*	CPU1: P1-DIMMC1/P1-DIMMB1/P1-DIMMA1/P1-DIMMA2/P1-DIMMD2/P1-DIMMD1/P1-DIMME1/P1-DIMMF1
2 CPUs & 2 DIMMs	CPU1: P1-DIMMA1 CPU2: P2-DIMMA1
2 CPUs & 4 DIMMs	CPU1: P1-DIMMA1/P1-DIMMD1 CPU2: P2-DIMMA1/P2-DIMMD1
2 CPUs & 6 DIMMs	CPU1: P1-DIMMC1/P1-DIMMB1/P1-DIMMA1 CPU2: P2-DIMMC1/P2-DIMMB1/P2-DIMMA1
2 CPUs & 8 DIMMs	CPU1: P1-DIMMB1/P1-DIMMA1/P1-DIMMD1/P1-DIMME1 CPU2: P2-DIMMB1/P2-DIMMA1/P2-DIMMD1/P2-DIMME1
2 CPUs & 10 DIMMs	CPU1: P1-DIMMC1/P1-DIMMB1/P1-DIMMA1/P1-DIMMD1/P1-DIMME1/P1-DIMMF1 CPU2: P2-DIMMB1/P2-DIMMA1/P2-DIMMD1/P2-DIMME1
2 CPUs & 12 DIMMs	CPU1: P1-DIMMC1/P1-DIMMB1/P1-DIMMA1/P1-DIMMD1/P1-DIMME1/P1-DIMMF1 CPU2: P2-DIMMC1/P2-DIMMB1/P2-DIMMA1/P2-DIMMD1/P2-DIMME1/P2-DIMMF1
2 CPUs & 14 DIMMs*	CPU1: P1-DIMMC1/P1-DIMMB1/P1-DIMMA1/P1-DIMMA2/P1-DIMMD1/P1-DIMME1/P1-DIMMF1 CPU2: P2-DIMMC1/P2-DIMMB1/P2-DIMMA1/P2-DIMMA2/P2-DIMMD1/P2-DIMME1/P2-DIMMF1
2 CPUs & 16 DIMMs*	CPU1: P1-DIMMC1/P1-DIMMB1/P1-DIMMA1/P1-DIMMA2/P1-DIMMD2/P1-DIMMD1/P1-DIMME1/P1-DIMMF1 CPU2: P2-DIMMC1/P2-DIMMB1/P2-DIMMA1/P2-DIMMA2/P2-DIMMD2/P2-DIMMD1/P2-DIMME1/P2-DIMMF1

*Unbalanced, not recommended.

Symmetric Population within One CPU Socket									
Modes	P1/P2-DIMMF1	P1/P2-DIMME1	P1/P2-DIMMD1	P1/P2-DIMMD2	P1/P2-DIMMA2	P1/P2-DIMMA1	P1/P2-DIMMB1	P1/P2-DIMMC1	Channel Config.
AD	DRAM1	DRAM1	DRAM1	DCPMM	DCPMM	DRAM1	DRAM1	DRAM1	2-1-1
MM	DRAM2	DRAM2	DRAM2	DCPMM	DCPMM	DRAM2	DRAM2	DRAM2	2-1-1
AD + MM	DRAM3	DRAM3	DRAM3	DCPMM	DCPMM	DRAM3	DRAM3	DRAM3	2-1-1
AD	DCPMM	DRAM1	DRAM1			DRAM1	DRAM1	DCPMM	1-1-1
MM	DCPMM	DRAM1	DRAM1			DRAM1	DRAM1	DCPMM	1-1-1
AD + MM	DCPMM	DRAM3	DRAM3			DRAM3	DRAM3	DCPMM	1-1-1

AD: App Direct, MM: Memory Mode

Asymmetric Population within One CPU Socket									
Modes	P1/P2-DIMMF1	P1/P2-DIMME1	P1/P2-DIMMD1	P1/P2-DIMMD2	P1/P2-DIMMA2	P1/P2-DIMMA1	P1/P2-DIMMB1	P1/P2-DIMMC1	Channel Config.
AD	DRAM1	DRAM1	DRAM1	-	DCPMM	DRAM1	DRAM1	DRAM1	2-1-1
AD*	DRAM1	DRAM1	DRAM1	-	DCPMM	DRAM1	DRAM1	DRAM1	2-1-1

*Second socket has no DCPMM

Legend (for the tables above)					
DDR4 Type					Capacity
DRAM1	RDIMM	3DS RDIMM	LRDIMM	3DS LRDIMM	Any Capacity
DRAM2	RDIMM	-		-	Refer to Validation Matrix below.
DRAM3	RDIMM	3DS RDIMM	LRDIMM	-	

Note: DDR4 single rank x8 is not available for DCPMM Memory Mode or App-Direct Mode.

Validation Matrix (DDR4 DIMMs Validated with DCPMM)			
DIMM Type	Ranks Per DIMM & Data Width (Stack)	DIMM Capacity (GB)	
		DRAM Density	
		4Gb	8Gb
RDIMM	1Rx4	8GB	16GB
	2Rx8	8GB	16GB
	2Rx4	16GB	32GB
LRDIMM	4Rx4	N/A	64GB
LRDIMM 3DS	8Rx4 (4H)	N/A	128GB

- For MM, general NM/FM ratio is between 1:4 and 1:16. Excessive capacity for FM can be used for AD. (NM = Near Memory; FM = Far Memory)
- For each individual population, rearrangements between channels are allowed as long as the resulting population is compliant with the PDG rules for the 82xx/62xx/52xx/42xx platform.
- For each individual population, please use the same DDR4 DIMM in all slots.
- For each individual population, sockets are normally symmetric with exceptions for 1 DCPMM per socket and 1 DCPMM per node case. Currently, DCPMM modules operate at 2666 MHz.
- No mixing of DCPMM and NVMDIMMs within the same platform is allowed.
- This DCPMM population guide targets a balanced DCPMM-to-DRAM-cache ratio in MM and MM + AD modes.

When 1 CPU is used:	Memory Population Sequence
1 CPU & 1 DIMM	CPU1: P1-DIMMA1
1 CPU & 2 DIMMs	CPU1: P1-DIMMA1/P1-DIMMD1
1 CPU & 3 DIMMs	CPU1: P1-DIMMC1/P1-DIMMB1/P1-DIMMA1
1 CPU & 4 DIMMs	CPU1: P1-DIMMB1/P1-DIMMA1/P1-DIMMD1/P1-DIMME1
1 CPU & 5 DIMMs (Unbalanced: not recommended)	CPU1: P1-DIMMC1/P1-DIMMB1/P1-DIMMA1/P1-DIMMD1/P1-DIMME1
1 CPU & 6 DIMM	CPU1: P1-DIMMC1/P1-DIMMB1/P1-DIMMA1/P1-DIMMD1/P1-DIMME1/P1-DIMMF1
1 CPU & 7 DIMMs (Unbalanced: not recommended)	CPU1:P1-DIMMC1/P1-DIMMB1/P1-DIMMA1/P1-DIMMA2/P1-DIMMD1/P1-DIMME1/ P1-DIMMF1
1 CPU & 8 DIMMs (Unbalanced: not recommended)	CPU1: P1-DIMMC1/P1-DIMMB1/P1-DIMMA1/P1-DIMMA2/P1-DIMMD2/P1-DIMMD1/ P1-DIMME1/P1-DIMMF1
When 2 CPUs are used:	Memory Population Sequence
2 CPUs & 2 DIMMs	CPU1: P1-DIMMA1 CPU2: P2-DIMMA1
2 CPUs & 4 DIMMs	CPU1: P1-DIMMA1/P1-DIMMD1 CPU2: P2-DIMMA1/P2-DIMMD1
2 CPUs & 6 DIMMs	CPU1: P1-DIMMC1/P1-DIMMB1/P1-DIMMA1 CPU2: P2-DIMMC1/P2-DIMMB1/P2-DIMMA1
2 CPUs & 8 DIMMs	CPU1: P1-DIMMB1/P1-DIMMA1/P1-DIMMD1/P1-DIMME1 CPU2: P2-DIMMB1/P2-DIMMA1/P2-DIMMD1/P2-DIMME1
2 CPUs & 10 DIMMs	CPU1: P1-DIMMC1/P1-DIMMB1/P1-DIMMA1/P1-DIMMD1/P1-DIMME1/P1-DIMMF1 CPU2: P2-DIMMB1/P2-DIMMA1/P2-DIMMD1/P2-DIMME1
2 CPUs & 12 DIMMs	CPU1: P1-DIMMC1/P1-DIMMB1/P1-DIMMA1/P1-DIMMD1/P1-DIMME1/P1-DIMMF1 CPU2: P2-DIMMC1/P2-DIMMB1/P2-DIMMA1/P2-DIMMD1/P2-DIMME1/P2-DIMMF1
2 CPUs & 14 DIMMs (Unbalanced: not recommended)	CPU1: P1-DIMMC1/P1-DIMMB1/P1-DIMMA1/P1-DIMMA2/P1-DIMMD1/P1-DIMME1/ P1-DIMMF1 CPU2: P2-DIMMC1/P2-DIMMB1/P2-DIMMA1/P2-DIMMA2/P2-DIMMD1/P2-DIMME1/ P2-DIMMF1
2 CPUs & 16 DIMMs (Unbalanced: not recommended)	CPU1: P1-DIMMC1/P1-DIMMB1/P1-DIMMA1/P1-DIMMA2/P1-DIMMD2/P1-DIMMD1/ P1-DIMME1/P1-DIMMF1 CPU2: P2-DIMMC1/P2-DIMMB1/P2-DIMMA1/P2-DIMMA2/P2-DIMMD2/P2-DIMMD1/ P2-DIMME1/P2-DIMMF1

Motherboard Battery

The motherboard uses non-volatile memory to retain system information when system power is removed. This memory is powered by a lithium battery residing on the motherboard.

Replacing the Battery

Begin by removing power from the system as described in Section 3.1 and remove the cover as described in Section 3.2.

1. Push aside the small clamp that covers the edge of the battery. When the battery is released, lift it out of the holder.
2. To insert a new battery, slide one edge under the lip of the holder with the positive (+) side facing up. Then push the other side down until the clamp snaps over it.

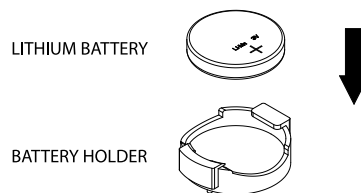

Figure 3-8. Installing the Onboard Battery

Warning: There is a danger of explosion if the onboard battery is installed upside down (which reverses its polarities). This battery must be replaced only with the same or an equivalent type recommended by the manufacturer (CR2032).

Note: Handle used batteries carefully. Do not damage the battery in any way; a damaged battery may release hazardous materials into the environment. Do not discard a used battery in the garbage or a public landfill. Please comply with the regulations set up by your local hazardous waste management agency to dispose of your used battery properly.

3.4 Chassis Components

Hard Drives

The SC118GHTS chassis supports four hot-swap 2.5" drive bays. The hard drives are mounted in drive carriers to simplify their installation and removal from the chassis. (Both procedures may be done without removing power from the system.)

Externally Accessible Drives

The hot-swap drives are mounted in drive carriers to simplify their installation and removal from the chassis. System power may remain on when removing carriers with drives installed. These carriers also help promote proper airflow for the drive bays. For this reason, even carriers without drives must remain in the chassis.

Removing a Hot-Swap Drive Carrier

1. Push the release button on the carrier. This extends the carrier handle.
2. Swing the handle fully out.
3. Grasp the handle and use it to pull the drive carrier out of its bay.

Mounting a Drive in a Drive Carrier

1. To add a new drive, install it into the carrier with the printed circuit board side facing down so that the mounting holes align with those in the carrier.
2. Secure the drive to the carrier with the screws provided, then push the carrier completely into the drive bay. You should hear a *click* when the drive is fully inserted. This indicates that the carrier has been fully seated and connected to the midplane, which automatically makes the power and logic connections to the hard drive.

Removing a Drive from a Drive Carrier

1. Remove the screws that secure the hard drive to the carrier and separate the hard drive from the carrier.
2. Replace the carrier back into the drive bay.

Note: Enterprise level hard disk drives are recommended for use in Supermicro chassis and servers. For information on recommended HDDs, visit the Supermicro website at <http://www.supermicro.com/products/nfo/files/storage/SBB-HDDCompList.pdf>

Hot-Swap for NVMe Drives

An NVMe drive can be inserted and replaced using IPMI.

Note: If you are using VROC, see the VROC appendix in this manual instead.

Ejecting a Drive

1. IPMI > Server Health > NVMe SSD

2. Select Device, Group and Slot, and click **Eject**. After ejecting, the drive Status LED indicator turns green.
3. Remove the drive.

Note that *Device* and *Group* are categorized by the CPLD design architecture. The 1029GP-TR server has one Device and one Group.

Slot is the slot number on which the NVMe drives are mounted.

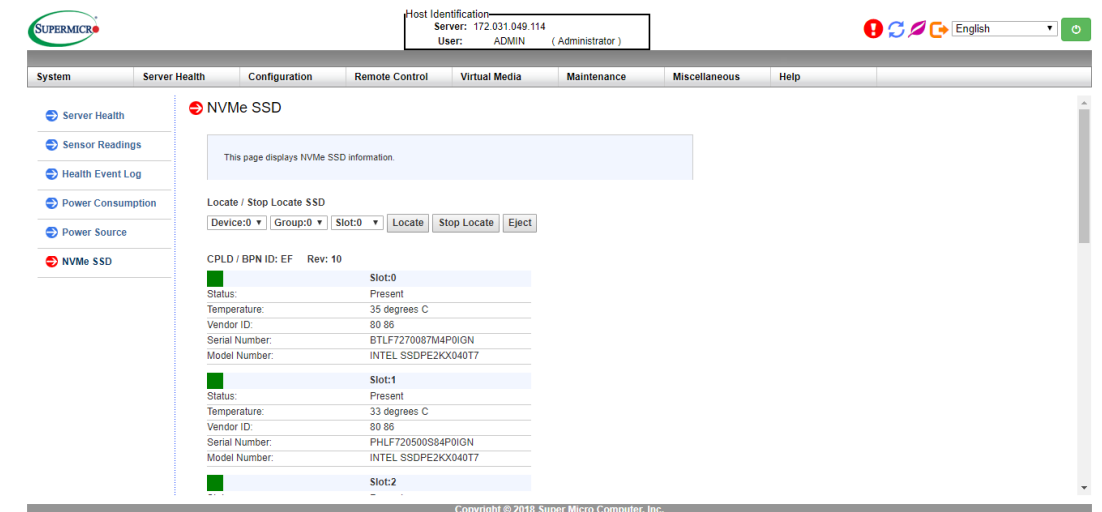

Figure 3-9. IPMI Screenshot

Replacing the Drive

1. Insert the replacement drive.
2. **IPMI > Server Health > NVMe SSD**
3. Select Device, Group and slot and click **Insert**. The drive Status LED indicator flashes red, then turns off. The Activity LED turns blue.

Checking the Temperature of an NVMe Drive

There are two ways to check using IPMI.

Checking a Drive

- **IPMI > Server Health > NVMe SSD** – Shows the temperatures of all NVMe drives, as in Figure 3-4.
- **IPMI > Server Health > Sensor Reading > NVME_SSD** – Shows the single highest temperature among all the NVMe drives.

Installing GPUs

The system supports up to three double-width graphics processor unit (GPU) cards, which are mounted in brackets to fit into the PCI-E slots (two in the front, one in the rear of the chassis). NVIDIA P40/P100/V100/coprocessor GPUs are supported. The GPUs may be already preinstalled. Use the procedure below if a GPU card must be replaced. See the NVIDIA website for more details on the GPU specifications.

Installing Graphics Cards

1. Remove power from the system as described in Section 3.1 and remove the cover as described in Section 3.2.
2. Identify the left and right brackets and graphics cards as illustrated below.
3. Insert the graphics cards into the brackets, aligning the mounting holes in the cards with those in the brackets, as shown in the figure below. The NVIDIA universal bracket (MCP-240-11803-0N) supports all NVIDIA GPU cards.
4. Secure each card to the bracket using the screws that are included for this purpose. Keplers: Remove the bracket on the end of the GPU, add a washer (included in kit) between the plate and the PCB for each screw, then attach the GPU to the bracket.
5. Carefully position each bracket in the chassis, aligning the four mounting holes in the top and side of each bracket with the corresponding mounting holes in the chassis. Pay attention to the airflow arrows to install each card into the correct side of the chassis.
6. Secure the bracket to the chassis by using the screws provided.
7. After a GPU card is installed, you must connect it to one of the following power headers on the motherboard: JPW3, JPW4, JPW6, or JPW7.

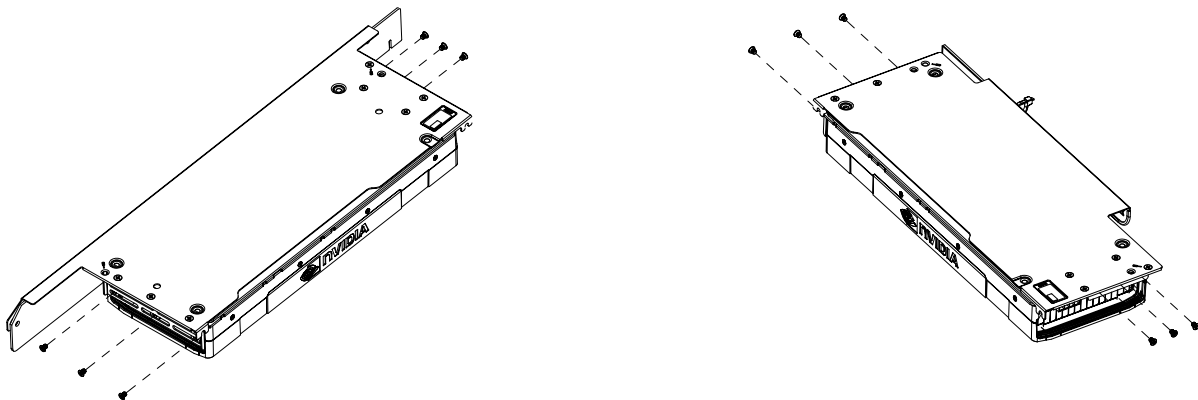

Figure 3-10. Installing GPUs into the Brackets

Installing Expansion Cards

The system accepts one low profile expansion card, mounted on a riser bracket (or two more in the rear instead of a GPU).

Installing an Expansion Card

1. Remove power from the system as described in Section 3.1 and remove the cover as described in Section 3.2.
2. Locate the riser card bracket and the riser card.
3. Remove the PCI slot shield at the rear of the chassis.
4. Attach the riser card to the riser card bracket using screws.
5. Insert the riser card into the motherboard expansion slot while aligning the riser card bracket with the rear of the chassis. Secure the bracket with screws.
6. Insert the expansion card into a slot on the riser card while aligning the expansion card backplate with the open slot in the rear of the chassis.

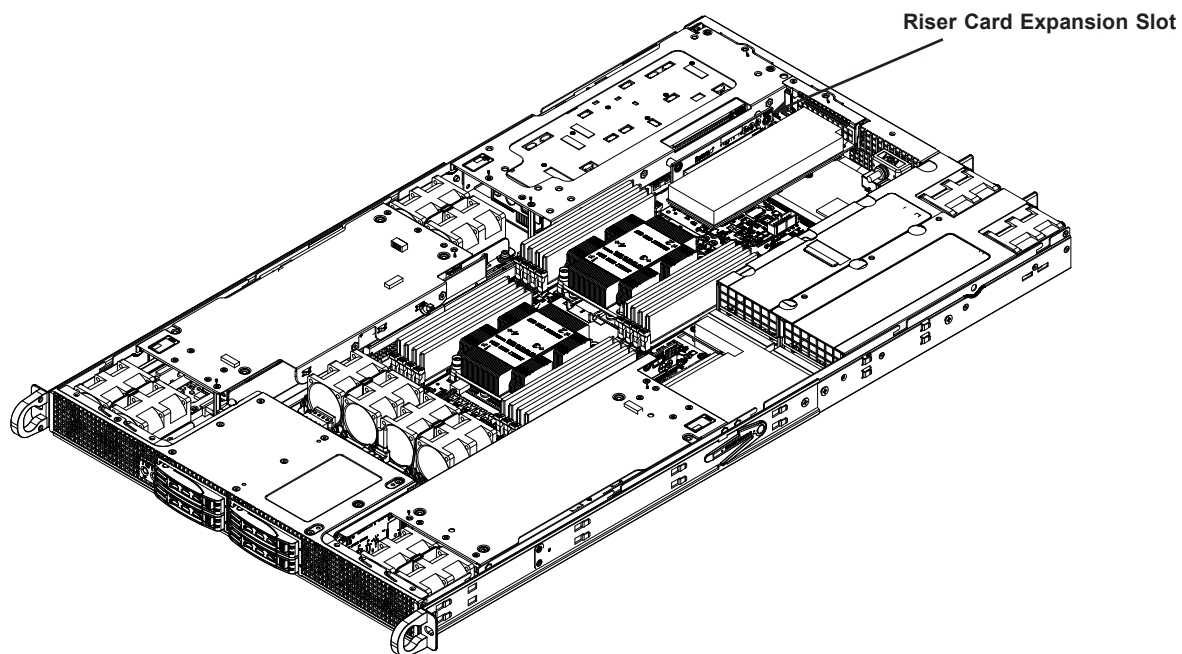

Figure 3-11. Riser Card Bracket and Expansion Slot

Installing an SIOM Card

The SIOM card provides options for network connection. It is inserted into a SIOM slot on the motherboard. This installation is usually performed by a system integrator or manufacturer.

1. Remove power from the system as described in Section 3.1 and remove the cover as described in Section 3.2.
2. Position the card with its cover bracket in front of the SIOM slot and gently push in both sides of the card until it slides into the slot.
3. Secure the SIOM card cover bracket to the chassis with the screw.

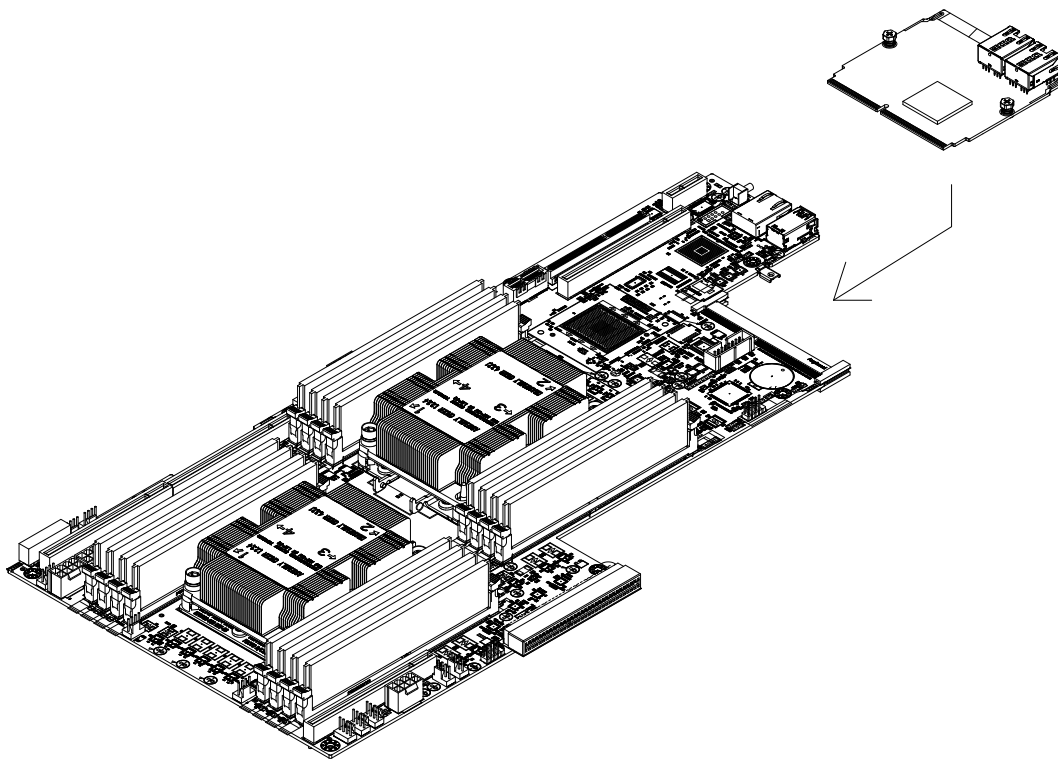

Figure 3-12. Installing an SIOM Card

System Cooling

Ten 4-cm counter-rotating fans provide the cooling for the system. Each fan unit is actually made up of two fans joined back-to-back, which rotate in opposite directions. This counter-rotating action generates exceptional airflow and works to dampen vibration levels.

It is very important that the chassis top cover is properly installed and making a good seal in order for the cooling air to circulate properly through the chassis and cool the components.

System Fan Failure

Fan speed is controlled by IPMI depending on the system temperature. If a fan fails, the remaining fans will ramp up to full speed. The system can continue to run with a failed fan. Replace any failed fan at your earliest convenience with the same model. Failed fans can be identified through the BIOS. The fan numbers are printed on the floor of the chassis.

Replacing a System Fan

If you do not use the BIOS to determine which fan has failed, open the top cover of the chassis while the system is running to locate the position of the failed fan. Never run the server for an extended period of time with the top cover open.

1. Remove power from the system as described in Section 3.1 and take off the cover as described in Section 3.2.
2. Remove the failed fan's wiring from the motherboard.
3. Remove the four pins securing the fan to the fan tray.
4. Lift the failed fan from the fan tray and out of the chassis.
5. Place the new fan into the vacant space in the fan tray, while making sure the arrows on the top of the fan (indicating air direction) point in the same direction as the arrows on the other fans in the same fan tray.
6. Reconnect the fan wires to the exact same chassis fan headers as the previous fan.
7. Reconnect the AC power cord, power up the system and check that the fan is working properly before replacing the chassis cover.

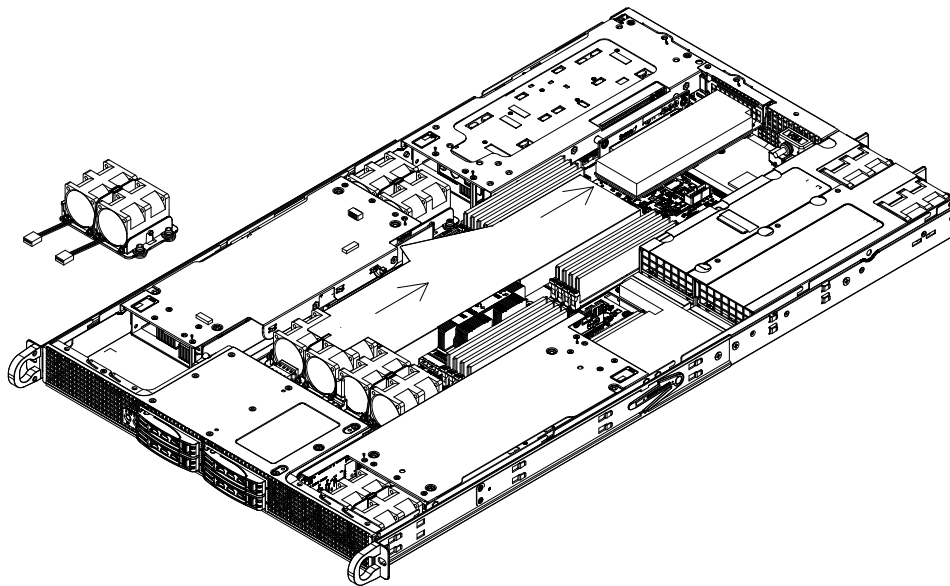

Figure 3-13. Installing a Fan

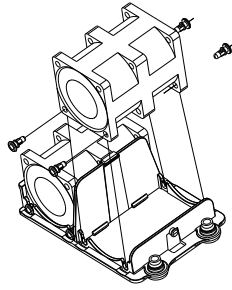

Figure 3-14. Removing a Fan from the Fan Tray

Installing the Air Shroud

Air shrouds concentrate airflow to maximize fan efficiency. The SC118GHTS chassis has an air shroud for each GPU. The motherboard air shroud does not require screws to install.

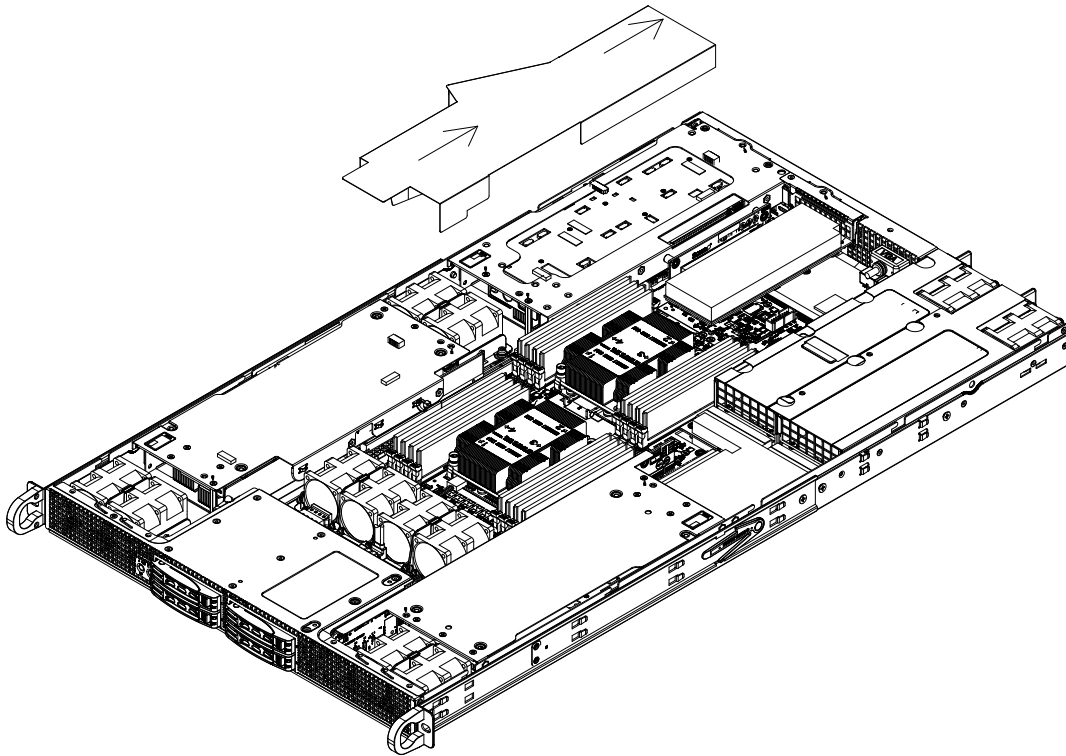

Figure 3-15. Installing the GPU Air Shroud

Installing the Air Shroud

1. Position the air shroud in the chassis as illustrated in above.
2. Align the notch on the air shroud with the pin on the expansion card bracket.
3. Slide the pin into the back of the notch.
4. Lower the front of the air shroud over the fan tray, sliding the front notches over the pins on the fan tray.

Power Supply

The server includes a 1600W redundant power supply consisting of two power modules. Each has an auto-switching capability, which enables it to automatically sense and operate with a 100V to 240V input voltage.

If either of the power supply modules fail, the other module will support the full load and allow the system to continue operation without interruption. The PWR Fail LED will illuminate and remain on until the failed unit has been replaced. Replace with the same model. Replacement units can be ordered directly from Supermicro.

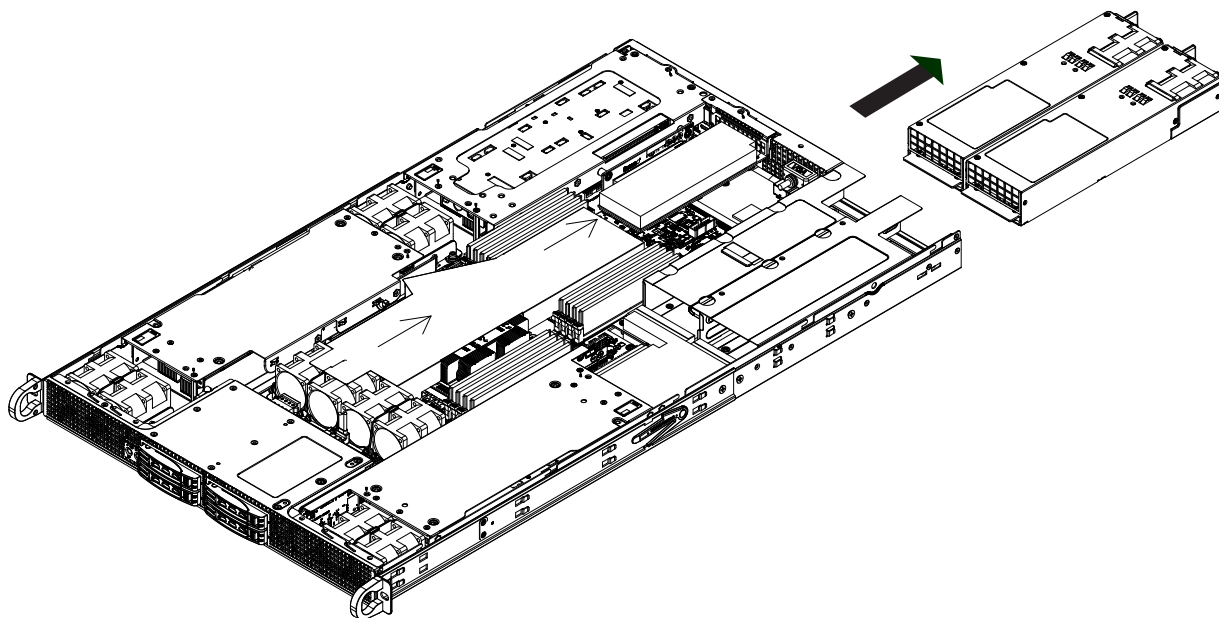

Figure 3-16. Removing a Power Supply

Replacing the Power Supply

1. Unplug the AC power cord from the failed power supply module.
2. Push in the locking tab at the back of the module to release it.
3. Pull the unit straight out of the chassis.
4. Carefully insert the new unit into position in the chassis, pushing it in until it clicks.
5. Reconnect the power cord.

Chapter 4

Motherboard Connections

This section describes the connections on the motherboard and provides pinout definitions. Note that depending on how the system is configured, not all connections are required. The LEDs on the motherboard are also described here. A motherboard layout indicating component locations may be found in Chapter 1.

Please review the Safety Precautions in Appendix B before installing or removing components.

4.1 Power Connections

The main power connection on the X11DPG-SN must be connected to the power supply. The wiring is included with the power supply.

- 8-pin Processor Power (JPWR2)

Main ATX Power

The power supply modules plug directly into the X11DPG-SN, so there is no cable connection that needs to be made for main power. However you must also connect the 8-pin power connectors (JPW3 - JPW7) to your power supply (see below) to provide power to the GPUs.

GPU Power Headers

JPW3-JPW7 are the 8-pin 12V DC power output for the GPUs.

GPU Power Pin Definitions	
Pin#	Definition
1 - 4	Ground
5 - 8	+12V

Required Connection

4.2 Headers and Connectors

Fan Headers

Eight 4-pin fan headers (FAN1~6, FANA, FANB) are located on the motherboard to provide CPU/system cooling. These 4-pin fan headers are backward compatible with traditional 3-pin fans. Fan speed control is supported by a thermal management setting in the BMC (Baseboard Management Controller) and is only available only when all 4-pin fans are used.

Fan Header Pin Definitions	
Pin#	Definition
1	Ground (Black)
2	+12V (Red)
3	Tachometer
4	PWM Control

TPM Header

The JTPM1 header is used to connect a Trusted Platform Module (TPM)/Port 80, which is available from Supermicro. A TPM/Port 80 connector is a security device that supports encryption and authentication in hard drives. It allows the motherboard to deny access if the TPM associated with the hard drive is not installed in the system.

Trusted Platform Module/Port 80 Header Pin Definitions			
Pin#	Definition	Pin#	Definition
1	+3.3V	2	SPI_CS#
3	RESET#	4	SPI_MISO
5	SPI_CLK	6	GND
7	SPI_MOSI	8	
9	+3.3V Stby	10	SPI_IRQ#

RAID Key Header

A RAID Key header is located at JRK1 on the motherboard. The RAID key is used to support NVMe RAID.

RAID Key Header Pin Definitions	
Pin#	Definition
1	Ground
2	PU 3.3V Stby
3	Ground
4	PCH RAID Key

SGPIO Header

The S-SGPIO1 (Serial General Purpose Input/Output) header is used to communicate with the enclosure management chip on the backplane.

SGPIO Header Pin Definitions			
Pin#	Definition	Pin#	Definition
1	NC	2	NC
3	Ground	4	DATA Out
5	Load	6	Ground
7	Clock	8	NC

NC = No Connection

Chassis Intrusion

A Chassis Intrusion header is located at JL1 on the motherboard. Attach the appropriate cable from the chassis to inform you of a chassis intrusion when the chassis is opened.

Chassis Intrusion Pin Definitions	
Pin#	Definition
1	Intrusion Input
2	Ground

BMC External I²C Header

A System Management Bus header for IPMI 2.0 is located at JIPMB1. Connect the appropriate cable here to use the I²C connection on your system.

External I ² C Header Pin Definitions	
Pin#	Definition
1	Data
2	Ground
3	Clock
4	No Connection

Speaker Header

A speaker header is located on JD1. Close pins 1-2 of JD1 to use the onboard speaker.

Speaker Connector Pin Definitions	
Pin Setting	Definition
Pin 1	Power
Pin 2	Buzzer

Serial Port

There is one COM connector (JCOM1) near the I/O back panel, next to the IPMI LAN connector. The COM connector provides serial communication support.

NVMe Slots

Use the two NVMe slots (NVME1 and NVME2) to attach high-speed PCI-E storage devices.

I-SATA 3.0 and S-SATA 3.0 Ports

The X11DPG-SN has ten SATA 3.0 ports (I-SATA0-3, I-SATA4-7 and S-SATA0 and S-SATA1), which are supported by the Intel C621 chipset. S-SATA0 can be used with Supermicro SuperDOM, a yellow SATA DOM connector with power pins built in that does not require external power cables. Supermicro SuperDOMs are backward-compatible with regular SATA HDDs or SATA DOMs that need external power cables.

Control Panel

JF1 contains header pins for various control panel connections. See the figure below for the pin locations and definitions of the control panel buttons and LED indicators.

All JF1 wires have been bundled into a single cable to simplify this connection. Make sure the red wire plugs into pin 1 as marked on the motherboard. The other end connects to the control panel PCB board.

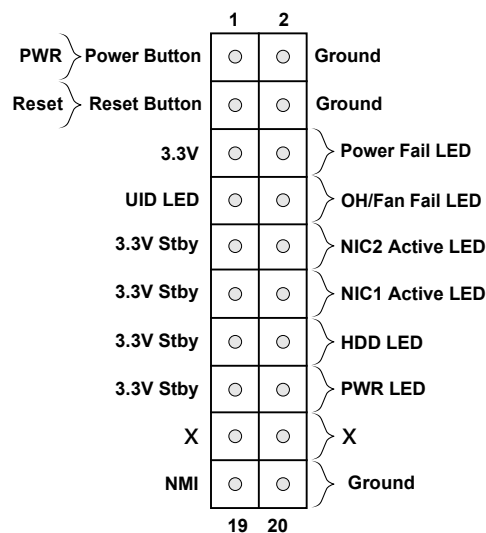

Figure 4-1. JF1: Control Panel Pins

Power Button

The Power Button connection is located on pins 1 and 2 of JF1. Momentarily contacting both pins will power on/off the system. This button can also be configured to function as a suspend button (with a setting in the BIOS - see Chapter 6). To turn off the power when the system is in suspend mode, press the button for 4 seconds or longer.

Power Button Pin Definitions (JF1)	
Pin#	Definition
1	Signal
2	Ground

Reset Button

The Reset Button connection is located on pins 3 and 4 of JF1. Attach it to a hardware reset switch on the computer chassis.

Reset Button Pin Definitions (JF1)	
Pin#	Definition
3	Reset
4	Ground

Power Fail LED

The Power Fail LED connection is located on pins 5 and 6 of JF1.

Power Fail LED Pin Definitions (JF1)	
Pin#	Definition
5	3.3V
6	PWR Supply Fail

Fan Fail and UID LED

Connect an LED cable to pins 7 and 8 of JF1 to use the Overheat/Fan Fail LED connections. The LED on pin 8 provides warnings of overheat or fan failure.

OH/Fan Fail Indicator Status	
Status	Definition
Off	Normal
On	Overheat
Flashing	Fan Fail

OH/Fan Fail LED Pin Definitions (JF1)	
Pin#	Definition
7	Blue LED
8	OH/Fan Fail LED

NIC1/NIC2 (LAN1/LAN2)

The NIC (Network Interface Controller) LED connection for LAN port 1 is located on pins 11 and 12 of JF1, and the LED connection for LAN Port 2 is on pins 9 and 10. Attach the NIC LED cables here to display network activity.

LAN1/LAN2 LED Pin Definitions (JF1)	
Pin#	Definition
9	NIC2 Activity LED
10	NIC2 Link LED
11	NIC1 Activity LED
12	NIC1 Link LED

HDD LED

The HDD LED connection is located on pins 13 and 14 of JF1. Attach a cable to Pin 14 to show hard drive activity status. Refer to the table below for pin definitions.

HDD LED Pin Definitions (JF1)	
Pin#	Definition
13	3.3V Standby
14	HDD Active

Power LED

The Power LED connection is located on pins 15 and 16 of JF1.

Power LED Pin Definitions (JF1)	
Pin#	Definition
15	3.3V Standby
16	Power LED

NMI Button

The non-maskable interrupt button header is located on pins 19 and 20 of JF1.

NMI Button Pin Definitions (JF1)	
Pin#	Definition
19	Control
20	Ground

4.3 Ports

Rear I/O Ports

See the figure below for the locations and descriptions of the various I/O ports on the rear of the motherboard

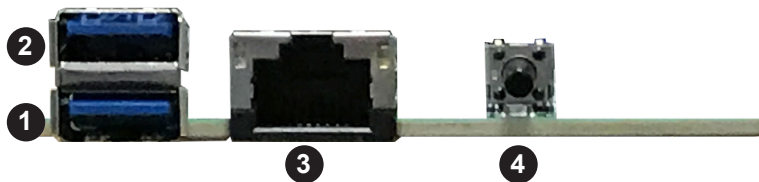

Rear I/O Ports			
No.	Description	No.	Description
1	USB0 Port (USB 3.0)	3	IPMI LAN Port
2	USB1 Port (USB 3.0)	4	Unit Identifier Switch

Universal Serial Bus (USB) Ports

There are two USB 3.0 ports (USB0/1) on the I/O back panel.

Back Panel USB 0/1 (3.0) Pin Definitions			
Pin#	Definition	Pin#	Definition
A1	VBUS	B1	Power
A2	D-	B2	USB_N
A3	D+	B3	USB_P
A4	GND	B4	GND
A5	Stda_SSRX-	B5	USB3_RN
A6	Stda_SSRX+	B6	USB3_RP
A7	GND	B7	GND
A8	Stda_SSTX-	B8	USB3_TN
A9	Stda_SSTX+	B9	USB3_TP

Ethernet Port

A dedicated IPMI LAN port are located on the back panel. This GbE Ethernet port accepts RJ45 type cables. Refer to the LED Indicator Section for LAN LED information.

Unit Identifier Switch/UID LED Indicator

A Unit Identifier (UID) switch and a rear UID LED (LE1) are located on the I/O back panel. A front UID switch connects to pins 7 & 8 of the front panel control (JF1). When you press the front or the rear UID switch, both front and rear UID LEDs will be turned on. Press the UID switch again to turn off the LED indicators. The UID indicators provide easy identification of a system that may be in need of service.

Note: UID can also be triggered via IPMI. For more information on IPMI, please refer to the IPMI User's Guide posted on our website at <http://www.supermicro.com>.

UID LED LED Indicator	
LED Color	Definition
Blue: On	Unit Identified

VGA Port

The VGA connector (JVGA) is located below the JSIOM slot and next to JTPM1 connector. Use this connection for VGA display.

4.4 Jumpers

Explanation of Jumpers

To modify the operation of the motherboard, jumpers are used to choose between optional settings. Jumpers create shorts between two pins to change the function associated with it. Pin 1 is identified with a square solder pad on the printed circuit board. See the motherboard layout page for jumper locations.

Note: On a two-pin jumper, "Closed" means the jumper is on both pins and "Open" indicates the jumper is either on only one pin or has been completely removed.

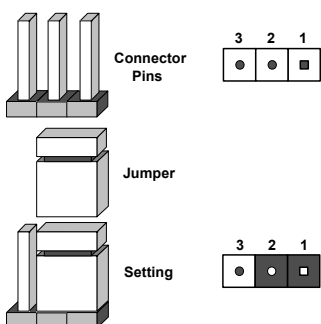

CMOS Clear

JBT1 is used to clear CMOS, which will also clear any passwords. Instead of pins, this jumper consists of contact pads to prevent accidentally clearing the contents of CMOS.

To Clear CMOS

1. First power down the system and unplug the power cord(s).
2. Remove the cover of the chassis to access the motherboard.
3. Remove the onboard battery from the motherboard.
4. Short the CMOS pads with a metal object such as a small screwdriver for at least four seconds.
5. Remove the screwdriver (or shorting device).
6. Replace the cover, reconnect the power cord(s) and power on the system.

Notes: Clearing CMOS will also clear all passwords.

Do not use the PW_ON connector to clear CMOS.



JBT1 contact pads

Manufacturing Mode Select

Close JPME2 to bypass SPI flash security and force the system to use the Manufacturing Mode, which will allow you to flash the system firmware from a host server to modify system settings.

Manufacturing Mode Select Jumper Settings	
Jumper Setting	Definition
Pins 1-2	Normal (Default)
Pins 2-3	Manufacturing Mode

Watch Dog

JWD controls the Watch Dog function. Watch Dog is a monitor that can reboot the system when a software application hangs. Jumping pins 1-2 will cause Watch Dog to reset the system if an application hangs. Jumping pins 2-3 will generate a non-maskable interrupt signal for the application that hangs. Watch Dog must also be enabled in BIOS.

The default setting is Reset.

Note: When Watch Dog is enabled, the user needs to write their own application software to disable it.

Watch Dog Jumper Settings	
Jumper Setting	Definition
Pins 1-2	Reset
Pins 2-3	NMI
Open	Disabled

VGA Enable/Disable

JPG1 allows you to enable or disable the VGA port that uses the onboard graphics controller. The default setting is Enabled.

VGA Enable/Disable Jumper Settings	
Jumper Setting	Definition
Pins 1-2	Enabled
Pins 2-3	Disabled

BIOS Recovery

The default setting is on pins 1 and 2 of jumper JBR1 for normal operation (Normal). For BIOS recovery, close pins 2-3.

BIOS Recovery Jumper Settings	
Jumper Setting	Definition
Pins 1-2	Normal
Pins 2-3	BIOS Recovery

Management Engine (ME) Recovery

Use jumper JPME1 to select ME Firmware Recovery mode and limit resource allocation to only essential system operation in order to maintain normal power operation and management. In the single operation mode, online upgrade will be available via Recovery mode.

Manufacturer Mode Jumper Settings	
Jumper Setting	Definition
Pins 1-2	Normal
Pins 2-3	ME Recovery

4.5 LED Indicators

BMC Heartbeat LED

LED M1 is the BMC heartbeat LED. When the LED is blinking green, BMC is functioning normally.

Onboard Power LED Indicator	
LED Color	Definition
Green: Blinking	BMC Normal

Onboard Power LED

The Onboard Power LED is located at LE2 on the motherboard. When this LED is on, the system is on. Be sure to turn off the system and unplug the power cord before removing or installing components.

Onboard Power LED Indicator	
LED Color	Definition
Off	System Off (power cable not connected)
Green	System On

Dedicated IPMI LAN Port LEDs

A dedicated IPMI LAN port is located on the I/O backplane. The amber LED on the right indicates activity, while the green LED on the left indicates the speed of the connection.

Unit ID LED

A rear UID LED indicator at LE1 is located near the UID switch on the back panel. This UID indicator provides easy identification of a system in a rack.

UID LED Indicator	
LED Color	Definition
Blue: On	Unit Identified

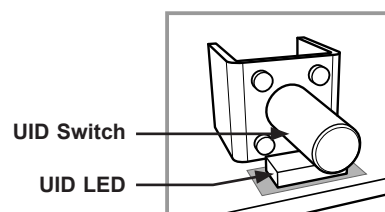

Chapter 5

Software

After the hardware has been installed, you can install the Operating System (OS), configure RAID settings and install the drivers.

5.1 Microsoft Windows OS Installation

If you will be using RAID, you must configure RAID settings before installing the Windows OS and the RAID driver. Refer to the RAID Configuration User Guides posted on our website at www.supernmicro.com/support/manuals.

Installing the OS

1. Create a method to access the MS Windows installation ISO file. That might be a DVD, perhaps using an external USB/SATA DVD drive, or a USB flash drive, or the IPMI KVM console.
2. Retrieve the proper RST/RSTe driver. Go to the Supermicro web page for your motherboard and click on "Download the Latest Drivers and Utilities", select the proper driver, and copy it to a USB flash drive.
3. Boot from a bootable device with Windows OS installation. You can see a bootable device list by pressing **F11** during the system startup.

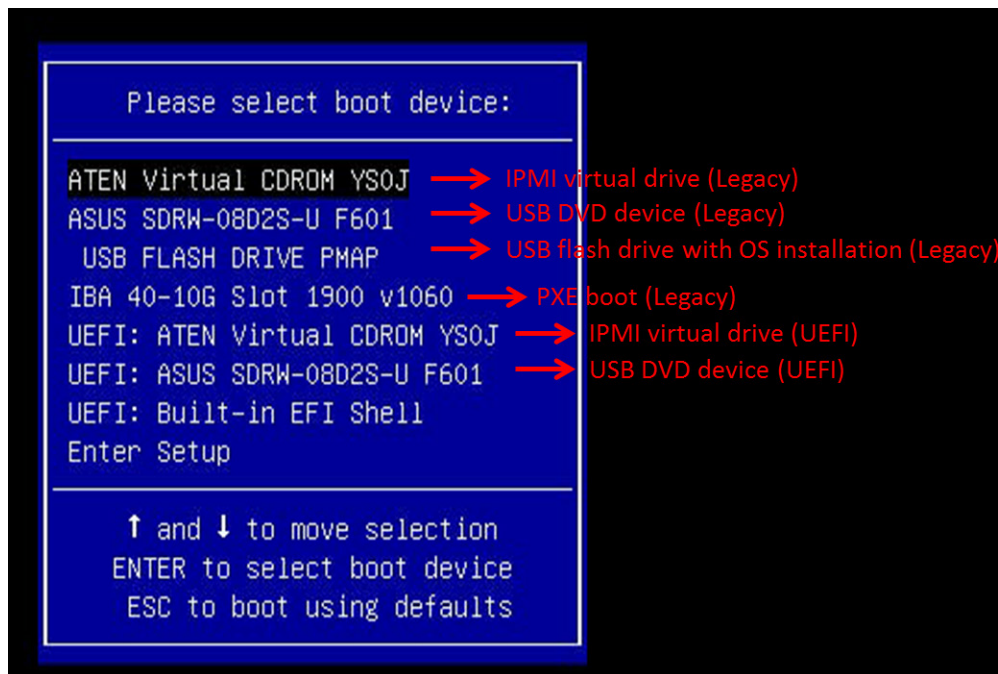

Figure 5-1. Select Boot Device

4. During Windows Setup, continue to the dialog where you select the drives on which to install Windows. If the disk you want to use is not listed, click on “Load driver” link at the bottom left corner.

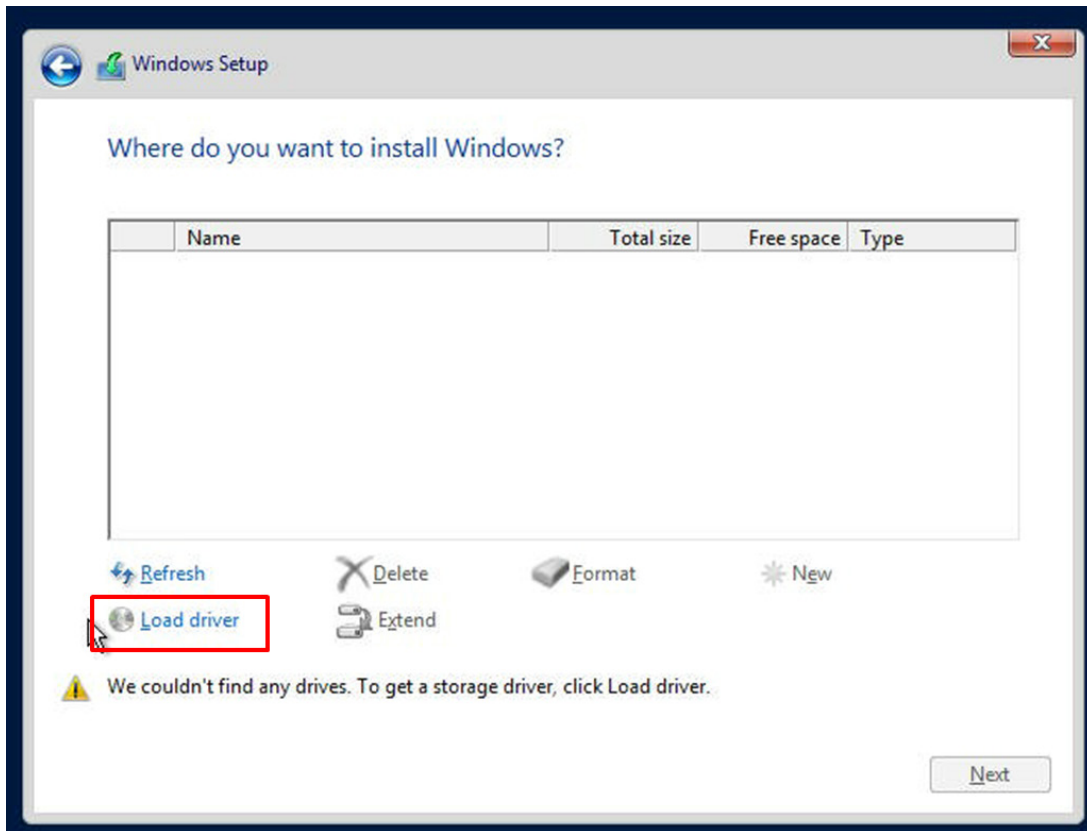

Figure 5-2. Load Driver Link

To load the driver, browse the USB flash drive for the proper driver files.

- For RAID, choose the SATA/sSATA RAID driver indicated then choose the storage drive on which you want to install it.
 - For non-RAID, choose the SATA/sSATA AHCI driver indicated then choose the storage drive on which you want to install it.
5. Once all devices are specified, continue with the installation.
 6. After the Windows OS installation has completed, the system will automatically reboot multiple times.

5.2 Driver Installation

The Supermicro website contains drivers and utilities for your system at <https://www.supermicro.com/wftp/driver>. Some of these must be installed, such as the chipset driver.

After accessing the website, go into the CDR_Images (in the parent directory of the above link) and locate the ISO file for your motherboard. Download this file to to a USB flash drive or a DVD. (You may also use a utility to extract the ISO file if preferred.)

Another option is to go to the Supermicro website at <http://www.supermicro.com/products/>. Find the product page for your motherboard, and "Download the Latest Drivers and Utilities".

Insert the flash drive or disk and the screenshot shown below should appear.

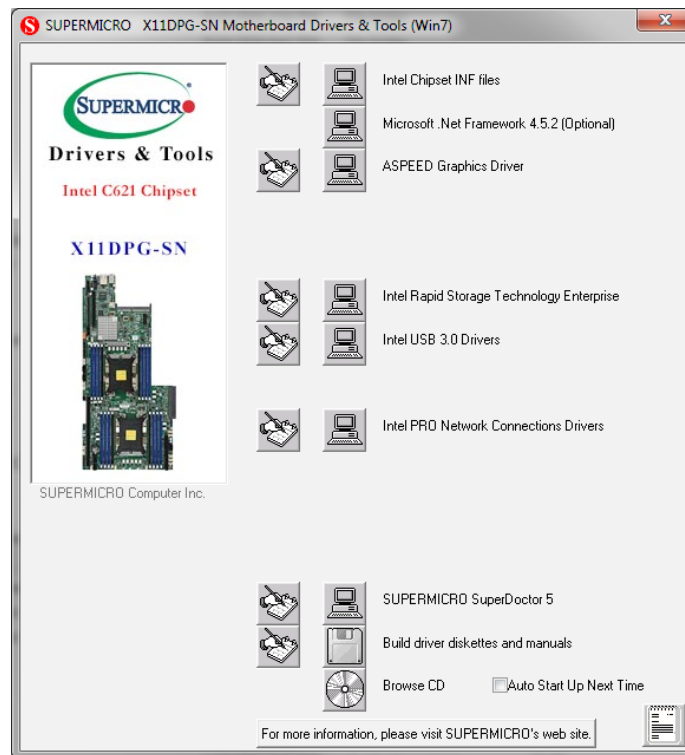

Figure 5-3. Driver & Tool Installation Screen

Note: Click the icons showing a hand writing on paper to view the readme files for each item. Click the computer icons to the right of these items to install each item (from top to the bottom) one at a time. **After installing each item, you must re-boot the system before moving on to the next item on the list.** The bottom icon with a CD on it allows you to view the entire contents.

5.3 SuperDoctor® 5

The Supermicro SuperDoctor 5 is a program that functions in a command-line or web-based interface for Windows and Linux operating systems. The program monitors such system health information as CPU temperature, system voltages, system power consumption, fan speed, and provides alerts via email or Simple Network Management Protocol (SNMP).

SuperDoctor 5 comes in local and remote management versions and can be used with Nagios to maximize your system monitoring needs. With SuperDoctor 5 Management Server (SSM Server), you can remotely control power on/off and reset chassis intrusion for multiple systems with SuperDoctor 5 or IPMI. SuperDoctor 5 Management Server monitors HTTP, FTP, and SMTP services to optimize the efficiency of your operation.

Note: The default User Name and Password for SuperDoctor 5 is ADMIN / ADMIN.

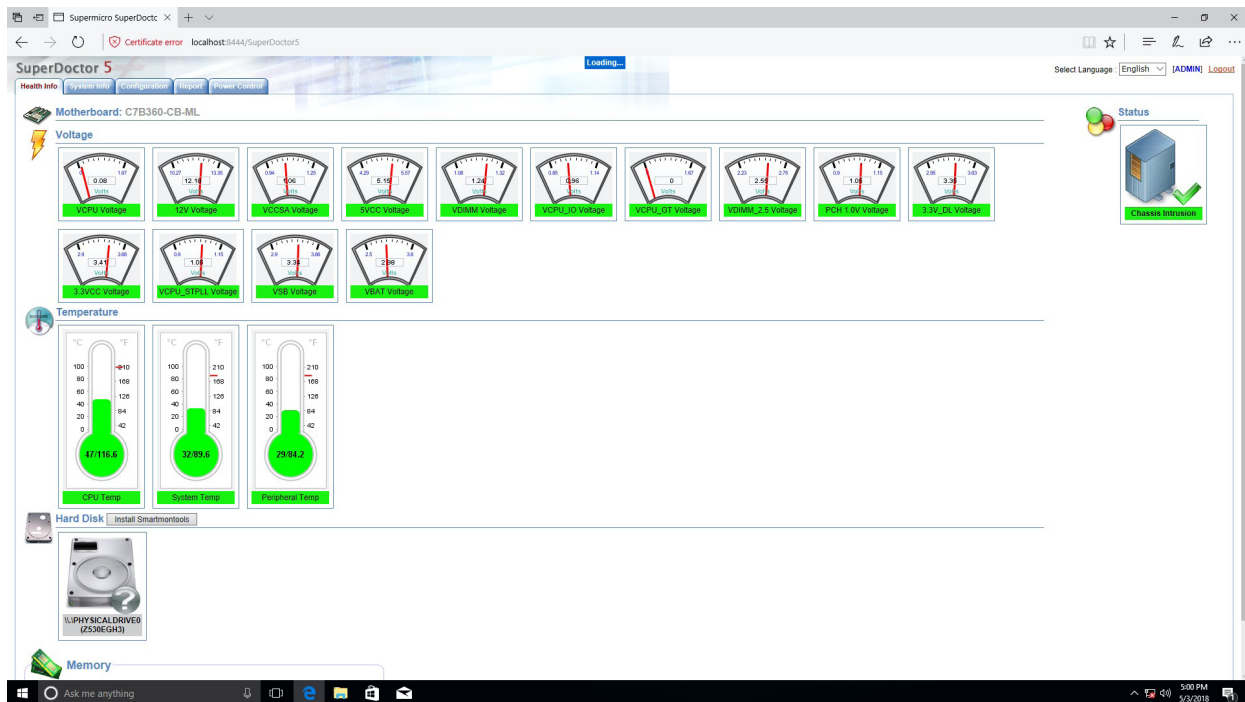

Figure 5-4. SuperDoctor 5 Interface Display Screen (Health Information)

5.4 IPMI

The X11DPG-SN supports the Intelligent Platform Management Interface (IPMI). IPMI is used to provide remote access, monitoring and management. There are several BIOS settings that are related to IPMI.

Supermicro ships standard products with a unique password for the BMC ADMIN user. This password can be found on a label on the motherboard.

Please visit our website for general documentation and information on IPMI.

Chapter 6

BIOS

6.1 Introduction

This chapter describes the AMIBIOS™ Setup utility for the X11DPG-SN motherboards. The BIOS is stored on a chip and can be easily upgraded using a flash program.

Note: Due to periodic changes to the BIOS, some settings may have been added or deleted and might not yet be recorded in this manual. Please refer to the Manual Download area of our website for any changes to BIOS that may not be reflected in this manual.

Starting the Setup Utility

To enter the BIOS setup utility, press the <Delete> key while the system is booting-up. (In most cases, the <Delete> key is used to invoke the BIOS setup screen. There are a few cases when other keys are used, such as <F1>, <F2>, etc.) Each main BIOS menu option is described in this manual.

The Main BIOS screen has two main frames. The left frame displays all the options that can be configured. "Grayed-out" options cannot be configured. The right frame displays the key legend. Above the key legend is an area reserved for a text message. When an option is selected in the left frame, it is highlighted in white. Often a text message will accompany it. (Note that BIOS has default text messages built in. We retain the option to include, omit, or change any of these text messages.) Settings printed in **Bold** are the default values.

A "▶" indicates a submenu. Highlighting such an item and pressing the <Enter> key will open the list of settings within that submenu.

The BIOS setup utility uses a key-based navigation system called hot keys. Most of these hot keys (<F1>, <F10>, <Enter>, <ESC>, <Arrow> keys, etc.) can be used at any time during the setup navigation process.

6.2 Main Setup

When you first enter the AMI BIOS setup utility, you will enter the Main setup screen. You can always return to the Main setup screen by selecting the Main tab on the top of the screen. The Main BIOS setup screen is shown below. The following Main menu items will be displayed:



System Date/System Time

Use this item to change the system date and time. Highlight System Date or System Time using the arrow keys. Enter new values using the keyboard. Press the <Tab> key or the arrow keys to move between fields. The date must be entered in Day MM/DD/YYYY format. The time is entered in HH:MM:SS format.

Note: The time is in the 24-hour format. For example, 5:30 P.M. appears as 17:30:00. The date's default value is 01/01/2014 after RTC reset.

Supermicro X11DPG-SN

BIOS Version

This item displays the version of the BIOS ROM used in the system.

Build Date

This item displays the date when the version of the BIOS ROM used in the system was built.

CPLD Version

This item displays the version of the CPLD (Complex-Programmable Logical Device) used in the system.

Memory Information

Total Memory

This item displays the total size of memory available in the system.

Memory Speed

This item displays the default speed of the memory modules installed in the system.

6.3 Advanced Setup Configurations

Use the arrow keys to select the Advanced submenu and press <Enter> to access the submenu items:

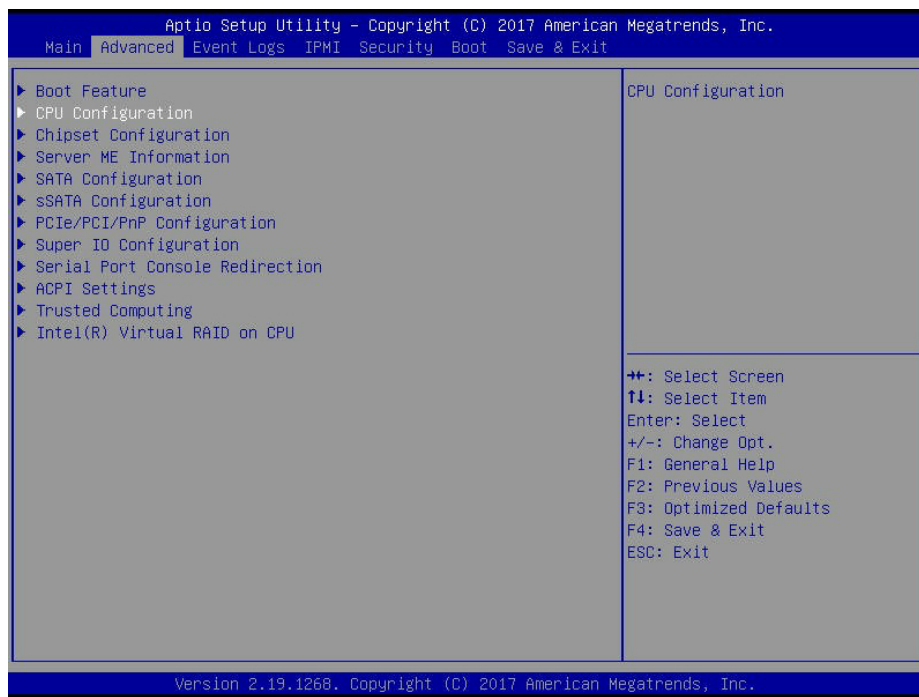

Warning: Take Caution when changing the Advanced settings. An incorrect value, an incorrect DRAM frequency, or an incorrect BIOS timing setting may cause the system to malfunction. When this occurs, restore the setting to the manufacture default setting.

► Boot Feature

Quiet Boot

Use this feature to select the screen between displaying POST messages or the OEM logo at bootup. Select Disabled to display the POST messages. Select Enabled to display the OEM logo instead of the normal POST messages. The options are Disabled and **Enabled**.

Note: POST message is always displayed regardless of the item setting.

Option ROM Messages

Use this feature to set the display mode for the Option ROM. Select Keep Current to use the current AddOn ROM display setting. Select Force BIOS to use the Option ROM display mode set by the system BIOS. The options are **Force BIOS** and Keep Current.

Bootup NumLock State

Use this feature to set the Power-on state for the Numlock key. The options are **On** and Off.

Wait For 'F1' If Error

Select Enabled to force the system to wait until the 'F1' key is pressed if an error occurs. The options are Disabled and **Enabled**.

Interrupt 19 Capture

Interrupt 19 is the software interrupt that handles the boot disk function. When this item is set to Immediate, the ROM BIOS of the host adaptors will "capture" Interrupt 19 at bootup immediately and allow the drives that are attached to these host adaptors to function as bootable disks. If this item is set to Postponed, the ROM BIOS of the host adaptors will not capture Interrupt 19 immediately and allow the drives attached to these adaptors to function as bootable devices at bootup. The options are **Immediate** and Postponed.

Re-try Boot

When EFI (Expansible Firmware Interface) Boot is selected, the system BIOS will automatically reboot the system from an EFI boot device after an initial boot failure. Select Legacy Boot to allow the BIOS to automatically reboot the system from a Legacy boot device after an initial boot failure. The options are **Disabled**, Legacy Boot, and EFI Boot.

Power Configuration

Watch Dog Function

Select Enabled to allow the Watch Dog timer to reboot the system when it is inactive for more than 5 minutes. The options are **Disabled** and Enabled.

Power Button Function

This feature controls how the system shuts down when the power button is pressed. Select 4 Seconds Override for the user to power off the system after pressing and holding the power button for 4 seconds or longer. Select Instant Off to instantly power off the system as soon as the user presses the power button. The options are **Instant Off** and 4 Seconds Override.

Restore on AC Power Loss

Use this feature to set the power state after a power outage. Select Power-Off for the system power to remain off after a power loss. Select Power-On for the system power to be turned on after a power loss. Select Last State to allow the system to resume its last power state before a power loss. The options are Power-On, Stay-Off and **Last State**.

▶ CPU Configuration

Warning: Setting the wrong values in the following sections may cause the system to malfunction.

▶ Processor Configuration

The following CPU information will be displayed:

- Processor BSP Revision
- Processor Socket
- Processor ID
- Processor Frequency
- Processor Max Ratio
- Processor Min Ratio
- Microcode Revision
- L1 Cache RAM
- L2 Cache RAM
- L3 Cache RAM
- Processor 0 Version
- Processor 1 Version

Hyper-Threading (ALL)

Select Enable to use Intel Hyper-Threading Technology to enhance CPU performance. The options are Disable and **Enable**.

Execute Disable Bit (Available if supported by the OS & the CPU)

Select Enable to enable Execute Disable Bit support which will allow the processor to designate areas in the system memory where an application code can execute and where it cannot, thus preventing a worm or a virus from flooding illegal codes to overwhelm the processor, damaging the system during a virus attack. The options are Disable and **Enable**. (Refer to Intel and Microsoft websites for more information.)

Intel Virtualization Technology

Select Enable to use Intel Virtualization Technology which will allow the I/O device assignments to be directly reported to the VMM (Virtual Memory Management) through the DMAR ACPI tables. This feature offers fully-protected I/O resource-sharing across the Intel platforms, providing the user with greater reliability, security and availability in networking and data-sharing. The settings are Disable and **Enable**.

PPIN Control

Select Unlock/Enable to use the Protected-Processor Inventory Number (PPIN) in the system. The options are Unlock/Disable and **Unlock/Enable**.

Hardware Prefetcher (Available when supported by the CPU)

If this feature is set to Enable, the hardware prefetcher will prefetch streams of data and instructions from the main memory to the Level 2 (L2) cache to improve CPU performance. The options are **Enable** and Disable.

Adjacent Cache Prefetch (Available when supported by the CPU)

Select Enable for the CPU to prefetch both cache lines for 128 bytes as comprised. Select Disable for the CPU to prefetch both cache lines for 64 bytes. The options are **Enable** and Disable.

Note: Please power off and reboot the system for the changes you've made to take effect. Please refer to Intel's website for detailed information.

DCU Streamer Prefetcher (Available when supported by the CPU)

If this item is set to Enable, the DCU (Data Cache Unit) streamer prefetcher will prefetch data streams from the cache memory to the DCU (Data Cache Unit) to speed up data accessing and processing for CPU performance enhancement. The options are **Enable** and Disable.

DCU IP Prefetcher

If this item is set to Enable, the IP prefetcher in the DCU (Data Cache Unit) will prefetch IP addresses to improve network connectivity and system performance. The options are **Enable** and Disable.

LLC Prefetch

If this feature is set to Enable, LLC (hardware cache) prefetching on all threads will be supported. The options are **Disable** and Enable.

Extended APIC (Extended Advanced Programmable Interrupt Controller)

Based on the Intel Hyper-Threading technology, each logical processor (thread) is assigned 256 APIC IDs (APIDs) in 8-bit bandwidth. When this feature is set to Enable, the APIC ID will be expanded from 8 bits to 16 bits to provide 512 APIDs to each thread to enhance CPU performance. The options are **Disable** and Enable.

AES-NI

Select Enable to use the Intel Advanced Encryption Standard (AES) New Instructions (NI) to ensure data security. The options are Disable and **Enable**.

► Advanced Power Management Configuration

► CPU P State Control

SpeedStep (PStates)

EIST (Enhanced Intel SpeedStep Technology) allows the system to automatically adjust processor voltage and core frequency in an effort to reduce power consumption and heat dissipation. Please refer to Intel's website for detailed information. The options are Disable and **Enable**.

EIST PSD Function (Available when SpeedStep is set to Enable)

Use this item to configure the processor's P-State coordination settings. During a P-State, the voltage and frequency of the processor will be reduced when it is in operation. This makes the processor more energy efficient, resulting in further energy gains. The options are **HW_ALL**, **SW_ALL** and **SW-ANY**.

Turbo Mode (Available when SpeedStep is set to Enable)

Select Enable for processor cores to run faster than the frequency specified by the manufacturer. The options are Disable and **Enable**.

► Hardware PM (Power Management) State Control

Hardware P-States

If this feature is set to Disable, hardware will choose a P-state setting for the system based on an OS request. If this feature is set to Native Mode, hardware will choose a P-state setting based on OS guidance. If this feature is set to Native Mode with No Legacy Support, hardware will choose a P-state setting independently without OS guidance. The options are **Disable**, **Native Mode**, **Out of Band Mode**, and **Native Mode with No Legacy Support**.

► CPU C State Control

Autonomous Core C-State

Select Enable to support Autonomous Core C-State control which will allow the processor core to control its C-State setting automatically and independently. The options are **Disable** and **Enable**.

CPU C6 Report

Select Enable to allow the BIOS to report the CPU C6 state (ACPI C3) to the operating system. During the CPU C6 state, power to all caches is turned off. The options are Disable, Enable and **Auto**.

Enhanced Halt State (C1E)

Select Enable to enable "Enhanced Halt State" support, which will significantly reduce the CPU's power consumption by minimizing CPU's clock cycles and reduce voltage during a "Halt State." The options are Disable and **Enable**.

► Package C State Control

Package C State

Use this feature to set the limit on the C-State package register. The options are C0/1 state, C2 state, C6 (non-Retention) state, C6 (Retention) state, No Limit, and Auto.

► Chipset Configuration

Warning: Setting the wrong values in the following sections may cause the system to malfunction.

► North Bridge

This feature allows the user to configure the settings for the Intel North Bridge.

► UPI (Ultra Path Interconnect) Configuration

This section displays the following UPI General Configuration information:

- Number of CPU
- Number of IIO
- Current UPI Link Speed
- Current UPI Link Frequency
- UPI Global MMIO Low Base/Limit
- UPI Global MMIO High Base/Limit
- UPI PCI-E Configuration Base/Size

Degrade Precedence

Use this feature to select the degrading precedence option for Ultra Path Interconnect connections. Select Topology Precedent to degrade UPI features if system options are in conflict. Select Feature Precedent to degrade UPI topology if system options are in conflict. The options are Topology Precedence and Feature Precedence.

Link L0p Enable

Select Enable to enable Link L0p. The options are Disable, Enable, and Auto.

Link L1 Enable

Select Enable to enable Link L1 (Level 1 link). The options are Disable, Enable, and Auto.

IO Directory Cache

Select Enable for the IODC (I/O Directory Cache) to generate snoops instead of generating memory lockups for remote IIO (InvlToM) and/or WCiLF (Cores). Select Auto for the IODC to generate snoops (instead of memory lockups) for WCiLF (Cores). The options are Disable, **Auto**, Enable for Remote InvltoM Hybrid Push, InvltoM AllocFlow, Enable for Remote InvltoM Hybrid AllocNonAlloc, and Enable for Remote InvltoM and Remote WViLF.

Isoc Mode

Select Enable to enable Isochronous support to meet QoS (Quality of Service) requirements. This feature is especially important for Virtualization Technology. The options are Disable, Enable, and **Auto**.

► Memory Configuration**Enforce POR**

Select POR to enforce POR restrictions for DDR4 memory frequency and voltage programming. The options are **POR** and Disable.

Memory Frequency

Use this feature to set the maximum memory frequency for onboard memory modules. The options are **Auto**, 1866, 2000, 2133, 2200, 2400, 2600, and 2666.

Data Scrambling for NVDIMM

Select Enable to enable data scrambling for onboard NVDIMM memory to enhance system performance and security. The options are **Auto**, Disable, and Enable.

Data Scrambling for DDR4

Select Enable to enable data scrambling for DDR4 memory to enhance system performance and security. The options are **Auto**, Disable, and Enable.

tCCD_L Relaxation

If this feature is set to Enable, SPD (Serial Presence Detect) will override tCCD_L ("Column to Column Delay-Long", or "Command to Command Delay-Long" on the column side.) If this feature is set to Disable, tCCD_L will be enforced based on the memory frequency. The options are Auto Enable and **Disable**.

Enable ADR

Select Enable for ADR (Automatic Diagnostic Repository) support to enhance memory performance. The options are **Disable** and Enable.

► Memory Topology

This item displays the information of onboard memory modules as detected by the BIOS.

- P1 DIMMA1
- P1 DIMMA2
- P2 DIMMB1
- P2 DIMMC1
- P1 DIMMD1
- P1 DIMMD2
- P1 DIMME1
- P1 DIMMF1
- P1 DIMMA1
- P1 DIMMA2
- P1 DIMMB1
- P1 DIMMC1
- P1 DIMMD1
- P1 DIMMD2
- P1 DIMME1
- P1 DIMMF1

► Memory RAS (Reliability_Availability_Serviceability) Configuration

Use this submenu to configure the following Memory RAS settings.

Static Virtual Lockstep Mode

Select Enable to support Static Virtual Lockstep mode to enhance memory performance. The options are **Disable** and Enable.

Mirror Mode

Select Enable to set all 1LM/2LM memory installed in the system on the mirror mode, which will create a duplicate copy of data stored in the memory to increase memory security, but it will reduce the memory capacity into half. The options are **Disable**, Mirror Mode 1LM and Mirror Mode 2LM.

Memory Rank Sparing

Select Enable to support memory-rank sparing to optimize memory performance. The options are **Disable** and Enable.

Note: This item will not be available when memory mirror mode is enabled.

Correctable Error Threshold

Use this item to enter the threshold value for correctable memory errors. The default setting is **10**.

SDDC Plus One

Select Enable for SDDC (Single Device Data Correction) Plus One support, which will increase the reliability and serviceability of your system memory. The options are **Disable** and Enable.

ADDDC (Adaptive Double Device Data Correction) Sparing

Select Enable for ADDDC sparing support to enhance memory performance. The options are **Disable** and Enable.

Patrol Scrub

Patrol Scrubbing is a process that allows the CPU to correct correctable memory errors detected in a memory module and send the corrections to the requestor (the original source). When this item is set to Enable, the IO hub will read and write back one cache line every 16K cycles if there is no delay caused by internal processing. By using this method, roughly 64 GB of memory behind the IO hub will be scrubbed every day. The options are Disable and **Enable**.

Patrol Scrub Interval

Use this item to specify the number of hours (between 0 to 24) required for the system to complete a full patrol scrubbing. Enter 0 for patrol scrubbing to be performed automatically. The default setting is **24**.

Note: This item is hidden when Patrol Scrub item is set to Disable.

► IIO Configuration

EV DFX (Device Function On-Hide) Features

When this feature is set to Enable, the EV_DFX Lock Bits that are located in a processor will always remain clear during electric tuning. The options are **Disable** and **Enable**.

► CPU1 Configuration/CPU2 Configuration

IOU0 (IIO PCIe Br1)

This item configures the PCI-E Bifurcation setting for a PCI-E port specified by the user. The options are x4x4x4x4, x4x4x8, x8x4x4, x8x8, x16, and **Auto**.

IOU1 (IIO PCIe Br2)

This item configures the PCI-E Bifurcation setting for a PCI-E port specified by the user. The options are x4x4x4x4, x4x4x8, x8x4x4, x8x8, x16, and **Auto**.

IOU2 (IIO PCIe Br3)

This item configures the PCI-E Bifurcation setting for a PCI-E port specified by the user. The options are x4x4x4x4, x4x4x8, x8x4x4, x8x8, x16, and **Auto**.

MCP0 (IIO PCIe Br4)

This item configures the PCI-E Bifurcation setting for a PCI-E port specified by the user. The options are x16 and **Auto**.

MCP1 (IIO PCIe Br5)

This item configures the PCI-E Bifurcation setting for a PCI-E port specified by the user. The options are x16 and **Auto**.

► **Socket 0 PCI-E Br0D00F0 - Port 0/DMI to Socket 0 PcieBr5D00F0 - MCP 1**

(Available for CPU 1 Configuration only)

Link Speed

This item configures the link speed of a PCI-E port specified by the user. The options are Auto, Gen 1 (Generation 1) (2.5 GT/s), Gen 2 (Generation 2) (5 GT/s), and Gen 3 (Generation 3) (8 GT/s)

The following information will be displayed as well:

- PCI-E Port Link Status
- PCI-E Port Link Max
- PCI-E Port Link Speed

PCI-E Port Max (Maximum) Payload Size (Available for CPU 1 Configuration only)

Select Auto for the system BIOS to automatically set the maximum payload value for a PCI-E device specified by to user to enhance system performance. The options are 128B, 256B and **Auto**.

IOAT Configuration

Disable TPH (TLP Processing Hint)

TPH is used for data-tagging with a destination ID and a few important attributes. It can send critical data to a particular cache without writing through to memory. Select No in this item for TLP Processing Hint support, which will allow a "TLP request" to provide "hints" to help optimize the processing of each transaction occurred in the target memory space. The options are **No** and Yes.

Prioritize TPH (TLP Processing Hint)

Select Yes to prioritize the TLP requests that will allow the "hints" to be sent to help facilitate and optimize the processing of certain transactions in the system memory. The options are Enable and **Disable**.

Relaxed Ordering

Select Enable to enable Relaxed Ordering support which will allow certain transactions to violate the strict-ordering rules of PCI and to be completed prior to other transactions that have already been enqueued. The options are **Disable** and Enable.

► Intel VT for Directed I/O (VT-d)

Intel® VT for Directed I/O (VT-d)

Select Enable to use Intel Virtualization Technology support for Direct I/O VT-d by reporting the I/O device assignments to the VMM (Virtual Machine Monitor) through the DMAR ACPI tables. This feature offers fully-protected I/O resource sharing across Intel platforms, providing greater reliability, security and availability in networking and data-sharing. The options are **Enable** and Disable.

Interrupt Remapping

Select Enable for Interrupt Remapping support to enhance system performance. The options are **Enable** and Disable.

PassThrough DMA

Select Enable for the Non-IscoH VT-d engine to pass through DMA (Direct Memory Access) to enhance system performance. The options are **Enable** and Disable.

ATS

Select Enable to enable ATS (Address Translation Services) support for the Non-IscoH VT-d engine to enhance system performance. The options are **Enable** and Disable.

Posted Interrupt

Select Enable to support VT_D Posted Interrupt which will allow external interrupts to be sent directly from a direct-assigned device to a client machine in non-root mode to improve virtualization efficiency by simplifying interrupt migration and lessening the need of physical interrupts. The options are **Enable** and Disable.

Coherency Support (Non-IscoH)

Select Enable for the Non-IscoH VT-d engine to pass through DMA (Direct Memory Access) to enhance system performance. The options are **Enable** and Disable.

► Intel® VMD Technology

► Intel® VMD for Onboard NVMe

Intel® VMD for Onboard NVMe

Onboard NVMe Mode

Select Legacy Mode for the onboard NVMe devices to support Legacy Mode. The options are **Legacy Mode** and the VMD Mode. When VMD Mode is selected, the following options become available:

- **P1_NVMe0 VMD** - The options are Disable and **Enable**
- **P1_NVMe1 VMD** - The options are Disable and **Enable**
- **Hot Plug Capable** - The options are Disable and **Enable**

IIO-PCIE Express Global Options

The section allows the user to configure the following PCI-E global options:

PCE-E Hot Plug

Select Enable to support Hot-plugging for the selected PCI-E slots which will allow the user to replace the devices installed in the slots without shutting down the system. The options are **Disable**, Enable, Auto and Manual.

PCI-E Completion Timeout (Global)

Use this item to select the PCI-E Completion Time-out settings. The options are **Yes**, No, and Per-Port.

► South Bridge

The following South Bridge information will display:

- USB Module Version
- USB Devices

Legacy USB Support

Select Enabled to support onboard legacy USB devices. Select Auto to disable legacy support if there are no legacy USB devices present. Select Disable to have all USB devices available for EFI applications only. The options are **Enabled**, Disabled and Auto.

XHCI Hand-Off

This is a work-around solution for operating systems that do not support XHCI (Extensible Host Controller Interface) hand-off. The XHCI ownership change should be claimed by the XHCI driver. The options are Enabled and **Disabled**.

Port 60/64 Emulation

Select Enabled for I/O port 60h/64h emulation support, which in turn, will provide complete legacy USB keyboard support for the operating systems that do not support legacy USB devices. The options are Disabled and **Enabled**.

Port 61h Bit-4 Emulation

Select Enabled for I/O Port 61h-Bit 4 emulation support to enhance system performance. The options are **Disabled** and Enabled.

Install Windows 7 USB Support

Select Enabled to install the Windows 7 USB utility to support legacy USB devices for Windows 7 systems. The options are **Disabled** and Enabled.

► Server ME (Management Engine) Configuration

This feature displays the following system ME configuration settings.

Operational Firmware Version

Backup Firmware Version

Recovery Firmware Version

ME Firmware Status #1

ME Firmware Status #2

 Current State

 Error Code

► SATA Configuration

When this submenu is selected, the AMI BIOS automatically detects the presence of the SATA devices that are supported by the Intel PCH chip and displays the following items:

SATA Controller

This item enables or disables the onboard SATA controller supported by the Intel PCH chip. The options are Disable and **Enable**.

Configure SATA as (Available when the item above: SATA Controller is set to enabled)

Select AHCI to configure a SATA drive specified by the user as an AHCI drive. Select RAID to configure a SATA drive specified by the user as a RAID drive. The options are **AHCI** and RAID. (**Note:** This item is hidden when the SATA Controller item is set to Disabled.)

SATA HDD Unlock

Select Enable to unlock SATA HDD password in the OS. The options are Disable and **Enable**.

SATA/sSATA RAID Boot Select

This feature allows the user to decide which controller should be used for system boot. The options are None, SATA Controller, **sSATA Controller** and Both.

Aggressive Link Power Management

When this item is set to Enabled, the SATA AHCI controller manages the power use of the SATA link. The controller will put the link in a low power mode during an extended period of I/O inactivity, and will return the link to an active state when I/O activity resumes. The options are **Disable** and Enable.

SATA RAID Option ROM/UEFI Driver (Available when the item "Configure SATA as" is set to "RAID")

Select EFI to load the EFI driver for system boot. Select Legacy to load a legacy driver for system boot. The options are **Legacy**, EFI and Disable.

SATA Port 0 - SATA Port 7

Hot Plug

Select Enable to support Hot-plugging for the device installed on a selected SATA port which will allow the user to replace the device installed in the slot without shutting down the system. The options are **Enable** and Disabled.

Spin Up Device

On an edge detect from 0 to 1, set this item to allow the SATA device installed on the SATA port specified by the user to start a COMRESET initialization. The options are Enable and **Disable**.

SATA Device Type

Use this item to specify if the device installed on the SATA port selected by the user should be connected to a Solid State drive or a Hard Disk Drive. The options are **Hard Disk Drive** and Solid State Drive.

► sSATA Configuration

When this submenu is selected, AMI BIOS automatically detects the presence of the sSATA devices that are supported by the sSATA controller and displays the following items:

sSATA Controller

This item enables or disables the onboard sSATA controller supported by the Intel SCU. The options are **Enable** and Disable.

Configure sSATA as

Select AHCI to configure an sSATA drive specified by the user as an AHCI drive. Select RAID to configure an sSATA drive specified by the user as a RAID drive. The options are **AHCI** and RAID. (**Note:** This item is hidden when the sSATA Controller item is set to Disabled.)

SATA HDD Unlock

Select Enable to unlock sSATA HDD password in the OS. The options are Disable and **Enable**.

SATA/sSATA RAID Boot Select (Available when the item "Configure SATA as" is set to "RAID")

This feature allows the user to decide which controller should be used for system boot. The options are None, SATA Controller, **sSATA Controller**, and Both.

Aggressive Link Power Management

When this item is set to Enable, the sSATA AHCI controller manages the power use of the SATA link. The controller will put the link in a low power mode during an extended period of I/O inactivity, and will return the link to an active state when I/O activity resumes. The options are **Disable** and Enable.

sSATA RAID Option ROM/UEFI Driver (Available when the item "Configure SATA as" is set to "RAID")

Select EFI to load the EFI driver for system boot. Select Legacy to load a legacy driver for system boot. The options are **Legacy**, EFI and Disable.

sSATA Port 0 - sSATA Port 5

Hot Plug

Select Enable to support Hot-plugging for the device installed on an sSATA port selected by the user which will allow the user to replace the device installed in the slot without shutting down the system. The options are **Disable** and Enabled.

Spin Up Device

On an edge detect from 0 to 1, set this item to allow the sSATA device installed on the sSATA port specified by the user to start a COMRESET initialization. The options are Enable and **Disable**.

sSATA Device Type

Use this item to specify if the device installed on the sSATA port specified by the user should be connected to a Solid State drive or a Hard Disk Drive. The options are **Hard Disk Drive** and Solid State Drive.

► PCIe/PCI/PnP Configuration

The following PCI information will be displayed:

- PCI Bus Driver Version
- PCI Devices Common Settings:

Above 4G Decoding (Available if the system supports 64-bit PCI decoding)

Select Enabled to decode a PCI device that supports 64-bit in the space above 4G Address. The options are Disabled and **Enabled**.

SR-IOV Support (Available if the system supports Single-Root Virtualization)

Select Enabled for Single-Root IO Virtualization support. The options are **Disabled** and Enabled.

MMIOHBase

Use this item to select the base memory size according to memory-address mapping for the IO hub. The base memory size must be between 4032G to 4078G. The options are **56T**, 48T, 24T, 16T, 4T, and 1T.

MMIO High Granularity Size

Use this item to select the high memory size according to memory-address mapping for the IO hub. The options are 1G, 4G, 16G, 64G, **256G**, and 1024G.

PCI PERR/SERR Support

Use this feature to enable or disable the runtime event for SERR (System Error)/ PERR (PCI/PCI-E Parity Error). The options are Disabled and **Enabled**.

Maximum Read Request

Select Auto for the system BIOS to automatically set the maximum size for a read request for a PCI-E device to enhance system performance. The options are **Auto**, 128 Bytes, 256 Bytes, 512 Bytes, 1024 Bytes, 2048 Bytes, and 4096 Bytes.

MMCFG Base

This feature determines the lowest MMCFG (Memory-Mapped Configuration) base assigned to PCI devices. The options are 1G, 1.5G, 1.75G, **2G**, 2.25G, and 3G.

VGA Priority

Use this item to select the graphics device to be used as the primary video display for system boot. The options are Auto, **Onboard** and Offboard.

PCI Devices Option ROM Settings

Onboard NVME1/NVME2 OPROM

Select EFI to allow the user to boot the computer using an EFI (Expansible Firmware Interface) device installed on the NVME connector specified by the user. Select Legacy to allow the user to boot the computer using a legacy device installed on the NVME connector specified by the user. The options are Disabled, Legacy and **EFI**.

CPU1 Slot 1 PCI-E 3.0 X16

The options are Disabled, **Legacy** and EFI.

CPU2 Slot 2 PCI-E 3.0 X16

The options are Disabled, **Legacy** and EFI.

CPU1 Slot 3 PCI-E 3.0 X16

The options are Disabled, **Legacy** and EFI.

CPU2 Slot 4 PCI-E 3.0 X16

The options are Disabled, **Legacy** and EFI.

CPU2 Slot 5 PCI-E 3.0 X8

The options are Disabled, **Legacy** and EFI.

Onboard Video Option ROM

Use this feature to select the Onboard Video Option ROM type. The options are Disabled, **Legacy** and EFI.

► Network Stack Configuration

Network Stack

Select Enabled to enable PXE (Preboot Execution Environment) or UEFI (Unified Extensible Firmware Interface) for network stack support. The options are Disabled and **Enabled**.

***If "Network Stack" is set to Enabled, the following items will display:**

Ipv4 PXE Support

Select Enabled to enable Ipv4 PXE boot support. If this feature is disabled, it will not create the Ipv4 PXE boot option. The options are Disabled and **Enabled**.

Ipv4 HTTP Support

Select Enabled to enable Ipv4 HTTP boot support. If this feature is disabled, it will not create the Ipv4 HTTP boot option. The options are **Disabled** and Enabled.

Ipv6 PXE Support

Select Enabled to enable Ipv6 PXE boot support. If this feature is disabled, it will not create the Ipv6 PXE boot option. The options are Disabled and **Enabled**.

Ipv6 HTTP Support

Select Enabled to enable Ipv6 HTTP boot support. If this feature is disabled, it will not create the Ipv6 HTTP boot option. The options are **Disabled** and Enabled.

PXE Boot Wait Time

Use this feature to select the wait time to press the <ESC> key to abort the PXE boot. The default is **0**.

Media Detect Time

Use this feature to select the wait time in seconds for the BIOS ROM to detect the LAN media (Internet connection or LAN port). The default is **1**.

Super IO Configuration

Super IO Chip AST2500

► Serial Port 1 Configuration

Serial Port

Select Enabled to enable the onboard serial port specified by the user. The options are Disabled and **Enabled**.

Device Settings

This item displays the base I/O port address and the Interrupt Request address of a serial port specified by the user.

Note: This item is hidden when Serial Port 1 is set to Disabled.

Change Settings

This feature specifies the base I/O port address and the Interrupt Request address of Serial Port 1. Select **Auto** for the BIOS to automatically assign the base I/O and IRQ address to a serial port specified.

The options for Serial Port 1 are **Auto**, (IO=3F8h; IRQ=4), (IO=3F8h; IRQ=3, 4, 5, 6, 7, 9, 10, 11, 12), (IO=2F8h; IRQ=3, 4, 5, 6, 7, 9, 10, 11, 12); (IO=3E8h; IRQ=3, 4, 5, 6, 7, 9, 10, 11, 12), and (IO=2E8h; IRQ=3, 4, 5, 6, 7, 9, 10, 11, 12).

► Serial Port 2 Configuration

Serial Port

Select Enabled to enable the onboard serial port specified by the user. The options are **Enabled** and Disabled.

Device Settings

This item displays the base I/O port address and the Interrupt Request address of a serial port specified by the user.

Note: This item is hidden when Serial Port 1 is set to Disabled.

Change Settings

This feature specifies the base I/O port address and the Interrupt Request address of Serial Port 2. Select Auto for the BIOS to automatically assign the base I/O and IRQ address to a serial port specified. The options for Serial Port 2 are **Auto**, (IO=2F8h; IRQ=3), (IO=3F8h; IRQ=3, 4, 5, 6, 7, 9, 10, 11, 12), (IO=2F8h; IRQ=3, 4, 5, 6, 7, 9, 10, 11, 12); (IO=3E8h; IRQ=3, 4, 5, 6, 7, 9, 10, 11, 12), and (IO=2E8h; IRQ=3, 4, 5, 6, 7, 9, 10, 11, 12).

Serial Port 2 Attribute

Select SOL to use COM Port 2 as a Serial_Over_LAN (SOL) port for console redirection. The options are **SOL** and COM.

► Serial Port Console Redirection

COM 1 Console Redirection

Select Enabled to enable COM Port 1 for Console Redirection, which will allow a client machine to be connected to a host machine at a remote site for networking. The options are **Disabled** and Enabled.

*If the item above set to Enabled, the following items will become available for configuration:

► Console Redirection Settings (for COM1)

Terminal Type

Use this feature to select the target terminal emulation type for Console Redirection. Select VT100 to use the ASCII Character set. Select VT100+ to add color and function key support. Select ANSI to use the Extended ASCII Character Set. Select VT-UTF8 to use UTF8 encoding to map Unicode characters into one or more bytes. The options are VT100, **VT100+**, VT-UTF8 and ANSI.

Bits Per second

Use this feature to set the transmission speed for a serial port used in Console Redirection. Make sure that the same speed is used in the host computer and the client computer. A lower transmission speed may be required for long and busy lines. The options are 9600, 19200, 38400, 57600 and **115200** (bits per second).

Data Bits

Use this feature to set the data transmission size for Console Redirection. The options are 7 (Bits) and **8 (Bits)**.

Parity

A parity bit can be sent along with regular data bits to detect data transmission errors. Select Even if the parity bit is set to 0, and the number of 1's in data bits is even. Select Odd if the parity bit is set to 0, and the number of 1's in data bits is odd. Select None if you do not want to send a parity bit with your data bits in transmission. Select Mark to add a mark as a parity bit to be sent along with the data bits. Select Space to add a Space as a parity bit to be sent with your data bits. The options are **None**, Even, Odd, Mark and Space.

Stop Bits

A stop bit indicates the end of a serial data packet. Select 1 Stop Bit for standard serial data communication. Select 2 Stop Bits if slower devices are used. The options are **1** and **2**.

Flow Control

Use this feature to set the flow control for Console Redirection to prevent data loss caused by buffer overflow. Send a "Stop" signal to stop sending data when the receiving buffer is full. Send a "Start" signal to start sending data when the receiving buffer is empty. The options are **None** and Hardware RTS/CTS.

VT-UTF8 Combo Key Support

Select Enabled to enable VT-UTF8 Combination Key support for ANSI/VT100 terminals. The options are Disabled and **Enabled**.

Recorder Mode

Select Enabled to capture the data displayed on a terminal and send it as text messages to a remote server. The options are **Disabled** and Enabled.

Resolution 100x31

Select Enabled for extended-terminal resolution support. The options are Disabled and **Enabled**.

Legacy OS Redirection Resolution

Use this feature to select the number of rows and columns used in Console Redirection for legacy OS support. The options are **80x24** and 80x25.

Putty KeyPad

This feature selects Function Keys and KeyPad settings for Putty, which is a terminal emulator designed for the Windows OS. The options are **VT100**, LINUX, XTERMR6, SCO, ESCN, and VT400.

Redirection After BIOS Post

Use this feature to enable or disable legacy Console Redirection after BIOS POST. When the option-Bootloader is selected, legacy Console Redirection is disabled before booting the OS. When the option-Always Enable is selected, legacy Console Redirection remains enabled upon OS bootup. The options are **Always Enable** and Bootloader.

COM2/SOL (Serial-Over-LAN)

Console Redirection (for SOL/COM2)

Select Enabled to use the SOL port for Console Redirection. The options are Disabled and **Enabled**.

**If the item above set to Enabled, the following items will become available for user's configuration:*

► Console Redirection Settings (for COM2/SOL)

Use this feature to specify how the host computer will exchange data with the client computer, which is the remote computer used by the user.

Terminal Type

Use this feature to select the target terminal emulation type for Console Redirection. Select VT100 to use the ASCII Character set. Select VT100+ to add color and function key support. Select ANSI to use the Extended ASCII Character Set. Select VT-UTF8 to use UTF8 encoding to map Unicode characters into one or more bytes. The options are VT100, **VT100+**, VT-UTF8 and ANSI,.

Bits Per Second

Use this feature to set the transmission speed for a serial port used in Console Redirection. Make sure that the same speed is used in the host computer and the client computer. A lower transmission speed may be required for long and busy lines. The options are 9600, 19200, 38400, 57600 and **115200** (bits per second).

Data Bits

Use this feature to set the data transmission size for Console Redirection. The options are 7 (Bits) and **8 (Bits)**.

Parity

A parity bit can be sent along with regular data bits to detect data transmission errors. Select Even if the parity bit is set to 0, and the number of 1's in data bits is even. Select Odd if the parity bit is set to 0, and the number of 1's in data bits is odd. Select None if you do not want to send a parity bit with your data bits in transmission. Select Mark to add a mark as a parity bit to be sent along with the data bits. Select Space to add a Space as a parity bit to be sent with your data bits. The options are **None**, Even, Odd, Mark and Space.

Stop Bits

A stop bit indicates the end of a serial data packet. Select 1 Stop Bit for standard serial data communication. Select 2 Stop Bits if slower devices are used. The options are **1** and 2.

Flow Control

Use this feature to set the flow control for Console Redirection to prevent data loss caused by buffer overflow. Send a "Stop" signal to stop sending data when the receiving buffer is full. Send a "Start" signal to start data-sending when the receiving buffer is empty. The options are **None** and Hardware RTS/CTS.

VT-UTF8 Combo Key Support

Select Enabled to enable VT-UTF8 Combination Key support for ANSI/VT100 terminals. The options are Disabled and **Enabled**.

Recorder Mode

Select Enabled to capture the data displayed on a terminal and send it as text messages to a remote server. The options are **Disabled** and Enabled.

Resolution 100x31

Select Enabled for extended-terminal resolution support. The options are Disabled and **Enabled**.

Legacy OS Redirection Resolution

Use this feature to select the number of rows and columns used in Console Redirection for legacy OS support. The options are **80x24** and 80x25.

Putty KeyPad

This feature selects Function Keys and KeyPad settings for Putty, which is a terminal emulator designed for the Windows OS. The options are **VT100**, LINUX, XTERMR6, SCO, ESCN, and VT400.

Redirection After BIOS Post

Use this feature to enable or disable legacy Console Redirection after BIOS POST (Power-On Self-Test). When this feature is set to Bootloader, legacy Console Redirection is disabled before booting the OS. When this feature is set to Always Enable, legacy Console Redirection remains enabled upon OS boot. The options are **Always Enable** and Bootloader.

► Legacy Console Redirection Settings

Legacy Console Redirection Settings

Use the feature to select the COM port to display redirection of Legacy OS and Legacy OPRM messages. The options are **COM1** and **COM2/SOL**.

Serial Port for Out-of-Band Management/Windows Emergency Management Services (EMS)

The submenu allows the user to configure Console Redirection settings to support Out-of-Band Serial Port management.

Console Redirection (for EMS)

Select Enabled to use a COM port selected by the user for EMS Console Redirection. The options are **Disabled** and Enabled.

**If the item above set to Enabled, the following items will become available for user's configuration:*

► EMS Console Redirection Settings

Out-of-Band Management Port

The feature selects a serial port in a client server to be used by the Windows Emergency Management Services (EMS) to communicate with a remote host server. The options are **COM1 (Console Redirection)** and COM2/SOL (Console Redirection).

Terminal Type

Use this feature to select the target terminal emulation type for Console Redirection. Select VT100 to use the ASCII character set. Select VT100+ to add color and function key support. Select ANSI to use the extended ASCII character set. Select VT-UTF8 to use UTF8 encoding to map Unicode characters into one or more bytes. The options are VT100, VT100+, **VT-UTF8** and ANSI.

Bits Per Second

This feature sets the transmission speed for a serial port used in Console Redirection. Make sure that the same speed is used in both host computer and the client computer. A lower transmission speed may be required for long and busy lines. The options are 9600, 19200, 57600, and **115200** (bits per second).

Flow Control

Use this feature to set the flow control for Console Redirection to prevent data loss caused by buffer overflow. Send a "Stop" signal to stop data-sending when the receiving buffer is full. Send a "Start" signal to start data-sending when the receiving buffer is empty. The options are **None**, Hardware RTS/CTS, and Software Xon/Xoff.

The setting for each these features is displayed:

Data Bits, Parity, Stop Bits**►ACPI Settings**

Use this feature to configure Advanced Configuration and Power Interface (ACPI) power management settings for your system.

NUMA Support (Available when the OS supports this feature)

Select Enabled to enable Non-Uniform Memory Access support to enhance system performance. The options are Disabled and **Enabled**.

WHEA Support

Select Enabled to support the Windows Hardware Error Architecture (WHEA) platform and provide a common infrastructure for the system to handle hardware errors within the Windows OS environment to reduce system crashes and to enhance system recovery and health monitoring. The options are Disabled and **Enabled**.

High Precision Timer

Select Enabled to activate the High Precision Event Timer (HPET) that produces periodic interrupts at a much higher frequency than a Real-time Clock (RTC) does in synchronizing multimedia streams, providing smooth playback and reducing the dependency on other timestamp calculation devices, such as an x86 RDTSC Instruction embedded in the CPU. The High Performance Event Timer is used to replace the 8254 Programmable Interval Timer. The options are Disabled and **Enabled**.

► Trusted Computing (Available when a TPM device is installed and detected by the BIOS)

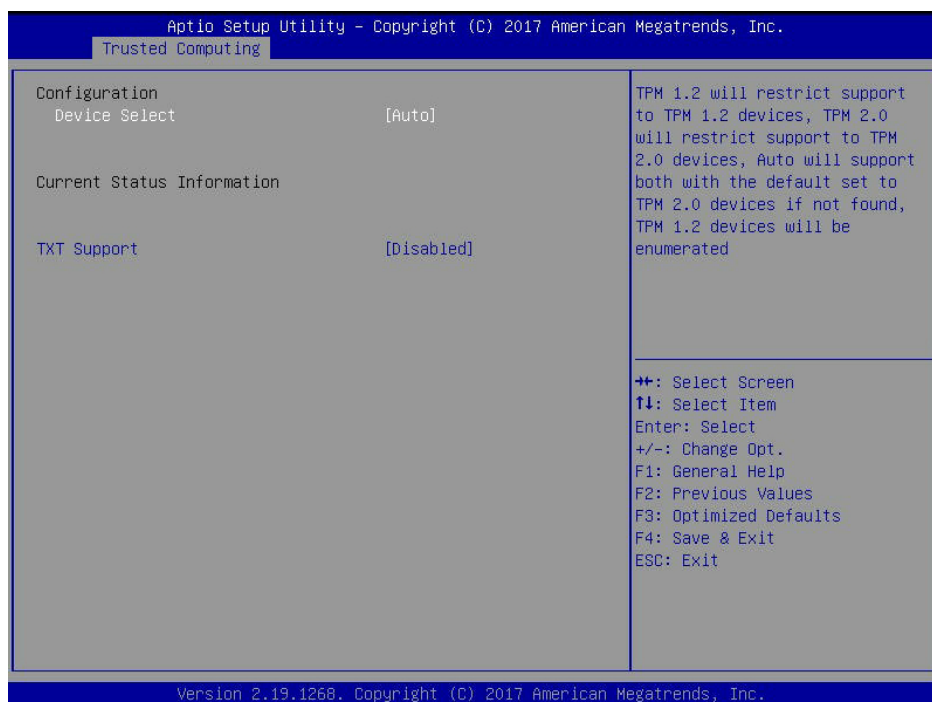

Device Select

The options are TPM 1.2, TPM 2.0 and **Auto**.

TXT Support

Select Enabled to enable Intel Trusted Execution Technology (TXT) support to enhance system security and data integrity. The options are **Disabled** and Enabled.

Note 1: If the option for this item (TXT Support) is set to Enabled, be sure to disable EV DFX (Device Function On-Hide) support for the system to work properly. (EV DFX is under "I/O Configuration" in the "Chipset/North Bridge" submenu).

Note 2: For more information on TPM, please refer to the TPM manual at <http://www.supermicro.com/manuals/other>.

► Intel® Virtual RAID on CPU

When this submenu is selected and the RAID devices are detected, the BIOS screen displays the following items:

Intel® VROC with VMD Technology 5.2.0.1029

No RAID volumes on the system

No Intel VMD Controllers on the sy

6.4 Event Logs

Use this feature to configure Event Log settings.



► Change SMBIOS Event Log Settings

Enabling/Disabling Options

SMBIOS Event Log

Select Enabled to enable SMBIOS (System Management BIOS) Event Logging during system boot. The options are Disabled and **Enabled**.

Erasing Settings

Erase Event Log

Select Enabled to erase all error events in the SMBIOS (System Management BIOS) log before an event logging is initialized at bootup. The options are **No**, Yes, Next Reset, and Yes, Next Reset.

When Log is Full

Select Erase Immediately to immediately erase all errors in the SMBIOS event log when the event log is full. Select Do Nothing for the system to do nothing when the SMBIOS event log is full. The options are **Do Nothing** and Erase Immediately.

SMBIOS Event Log Standard Settings

Log System Boot Event

Select Enabled to log system boot events. The options are Enabled and **Disabled**.

MECI (Multiple Event Count Increment)

Enter the increment value for the multiple event counter. Enter a number between 1 to 255. The default setting is 1.

METW (Multiple Event Count Time Window)

This item is used to determine how long (in minutes) should the multiple event counter wait before generating a new event log. Enter a number between 0 to 99. The default setting is **60**.

Note: Please reboot the system for the changes to take effect.

Customer Options

Log OEM Codes

Select Enabled to log the EFI Status codes as OEM codes if these codes have not been converted to Legacy. The options are Disabled and **Enabled**.

Convert OEM Codes

Select Enabled to convert the EFI Status codes to standard SMBIOS codes. Please note that this option is not available for all EFI Status codes. The options are **Disabled** and Enabled.

Note: Please reboot the system for the changes to take effect.

►View System Event Log

This item allows the user to view the event in the system event log. Select this item and press <Enter> to view the status of an event in the log. The following categories are displayed:

Date/Time/Error Code/Severity

6.5 IPMI

Use this feature to configure Intelligent Platform Management Interface (IPMI) settings.

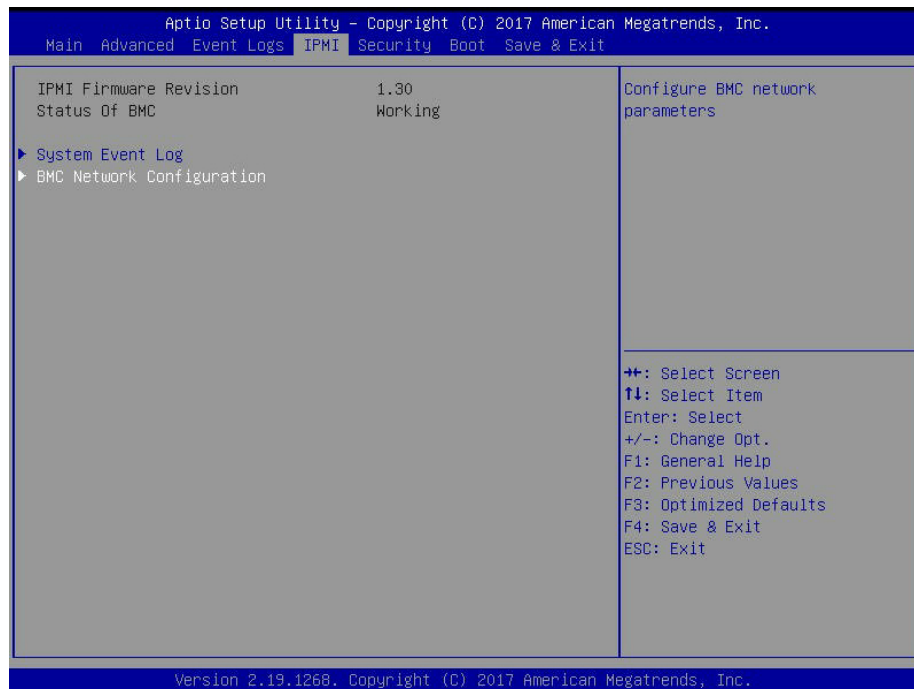

When you select this submenu and press the <Enter> key, the following information will display:

- IPMI Firmware Revision: This item indicates the IPMI firmware revision used in your system.
- Status of BMC: This item indicates the status of the BMC (Baseboard Management Controller) installed in your system.

► System Event Log

Enabling/Disabling Options

SEL Components

Select Enabled for all system event logging at bootup. The options are Disabled and **Enabled**.

Erasing Settings

Erase SEL

Select Yes, On next reset to erase all system event logs upon next system reboot. Select Yes, On every reset to erase all system event logs upon each system reboot. Select No to keep all system event logs after each system reboot. The options are **No**, Yes, On next reset, and Yes, On every reset.

When SEL is Full

This feature allows the user to determine what the BIOS should do when the system event log is full. Select Erase Immediately to erase all events in the log when the system event log is full. The options are **Do Nothing** and Erase Immediately.

Custom EFI Logging Options

Log EFI Status Codes

Select EFI (Extensible Firmware Interface) Status Codes to log EFI status codes. Select Error Codes to log EFI error codes. Select Progress Code to log the EFI progress code. Select both to log both EFI error codes and progress codes. The options are Disabled, Both, **Error code** and Progress code.

Note: After making changes on a setting, be sure to reboot the system for the changes to take effect.

► BMC Network Configuration

The following items will be displayed:

- IPMI LAN Selection: This item displays the IPMI LAN setting. The default setting is **Failover**.
- IPMI Network Link Status: This item displays the IPMI Network Link status. The default setting is **Shared LAN**.
- Current Configuration Address Source: This item displays the source of the current IPMI LAN address. The default setting is **CHCP (Dynamic Host Configuration Protocol)**.
- Station IP Address: This item displays the Station IP address for this computer. This should be in decimal and in dotted quad form (i.e., 192.168.10.253).
- Subnet Mask: This item displays the sub-network that this computer belongs to. The value of each three-digit number separated by dots should not exceed 255.
- Station MAC Address: This item displays the Station MAC address for this computer. Mac addresses are 6 two-digit hexadecimal numbers.
- Gateway IP Address: This item displays the Gateway IP address for this computer. This should be in decimal and in dotted quad form (i.e., 192.168.10.253).
- VLAN: This item displays the status of VLAN support.

Update IPMI LAN Configuration

Select Yes for the BIOS to implement all IP/MAC address changes at the next system boot. The options are **No** and Yes. If this option is set to Yes, the following items will display:

IPMI LAN Selection

Use this feature to select the type of the IPMI LAN. The options are Dedicated, Shared, and **Failover**.

VLAN

Select Enabled to enable IPMI VLAN function support. The options are **Enabled** and Disabled.

Configuration Address Source

Use this item to select the IP address source for this computer. If Static is selected, you will need to know the IP address of this computer and enter it to the system manually in the field. If DHCP is selected, AMI BIOS will search for a DHCP (Dynamic Host Configuration Protocol) server attached to the network and request the next available IP address for this computer. The options are Static and **DHCP**.

6.6 Security Settings

This menu allows the user to configure the following security settings for the system.

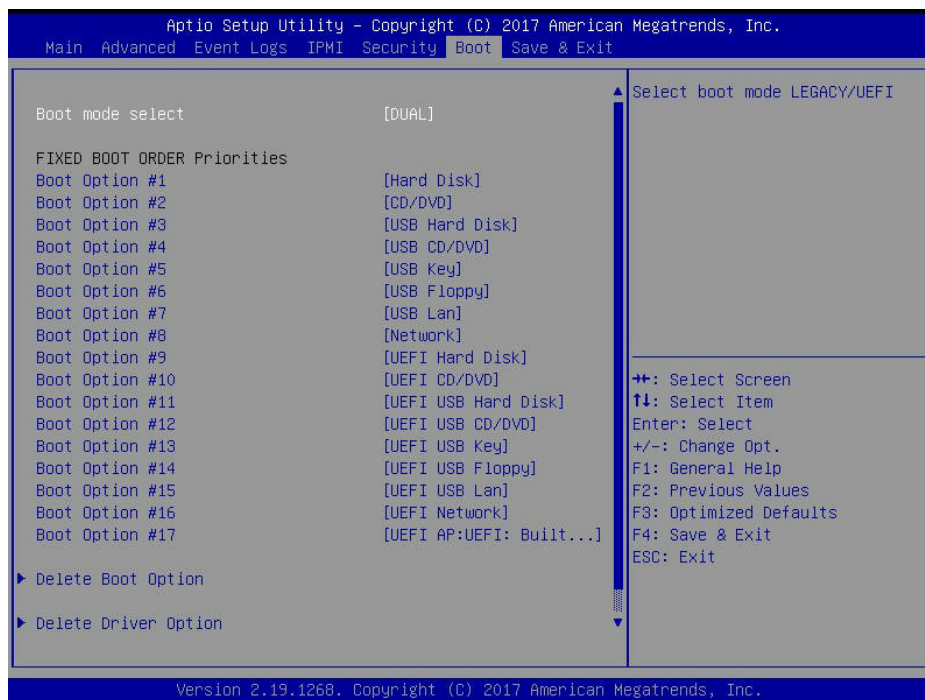

Administrator Password

Use this feature to set the administrator password which is required to enter the BIOS setup utility. The length of the password should be from 3 characters to 20 characters long.

User Password

Use this feature to set the user password which is required to enter the BIOS setup utility. The length of the password should be from 3 characters to 20 characters long.

Password Check

Select Setup for the system to check for a password at Setup. Select Always for the system to check for a password at bootup or upon entering the BIOS Setup utility. The options are **Setup** and Always.

► Secure Boot

When you select this submenu and press the <Enter> key, the following items will display:

- System Mode
- Secure Boot
- Vendor Keys

Attempt Secure Boot

If this item is set to Enabled, Secure Boot will be activated when a Platform Key (PK) is entered. A Platform Key is a security key used to manage the security settings of the platform firmware used in your system. The options are **Disabled** and Enabled.

Secure Boot Mode

Use this feature to select the desired secure boot mode for the system. The options are Standard and **Custom**.

CSM Support

Compatibility Support Module (CSM) allows for legacy BIOS compatibility by emulating a BIOS environment. The options are Disabled and **Enabled**.

►Key Management

Provision Factory Default Keys

Select Enabled to install all manufacturer default keys for the following system security settings. The options are **Disabled** and Enabled.

►Install Factor Default Keys

Select Yes to install all manufacturer defaults for the following system security settings. The options are **Yes** and No.

►Enroll EFI Image

Select this item and press <Enter> to select an EFI (Extensible Firmware Interface) image for the system to operate in Secure Boot mode.

►Save All Secure Boot Variables

This feature allows the user to set and save the secure boot key variables specified by the user.

Secure Boot Variables

Secure Boot Variable/Size/Key#/Key Sources

►Platform Key (PK)

This feature allows the user to enter and configure a set of values to be used as a platform firmware key for the system. This set of values also indicate the size, the keys numbers, and the key source of the Platform Key. The options are **Save to File**, Set New, and Erase.

▶Key Exchange Keys

This feature allows the user to enter and configure a set of values to be used as a Key-Exchange-Keys for the system. This set of values also indicate the size, the keys numbers, and the key source of the Key-Exchange-Keys. The options are **Save to File**, Set New, Append and Erase.

▶Authorized Signatures

This feature allows the user to enter and configure a set of values to be used as Authorized Signatures for the system. This set of values also indicate the size, the keys numbers, and the key source of the Authorized Signatures. The options are **Save to File**, Set New, Append and Erase.

▶Forbidden Signatures

This feature allows the user to enter and configure a set of values to be used as Forbidden Signatures for the system. This set of values also indicate the size, the keys numbers, and the key source of the Forbidden Signatures. The options are **Save to File**, Set New, Append and Erase.

▶Authorized TimeStamps

This feature allows the user to set and save the timestamps for Authorized Signatures to indicate when these signatures were entered into the system. The options are **Set New** and Append.

▶OsRecovery Signatures

This feature allows the user to set and save the Authorized Signatures used for OS recovery. The options are **Set New** and Append.

6.7 Boot Settings

Use this feature to configure Boot Settings:

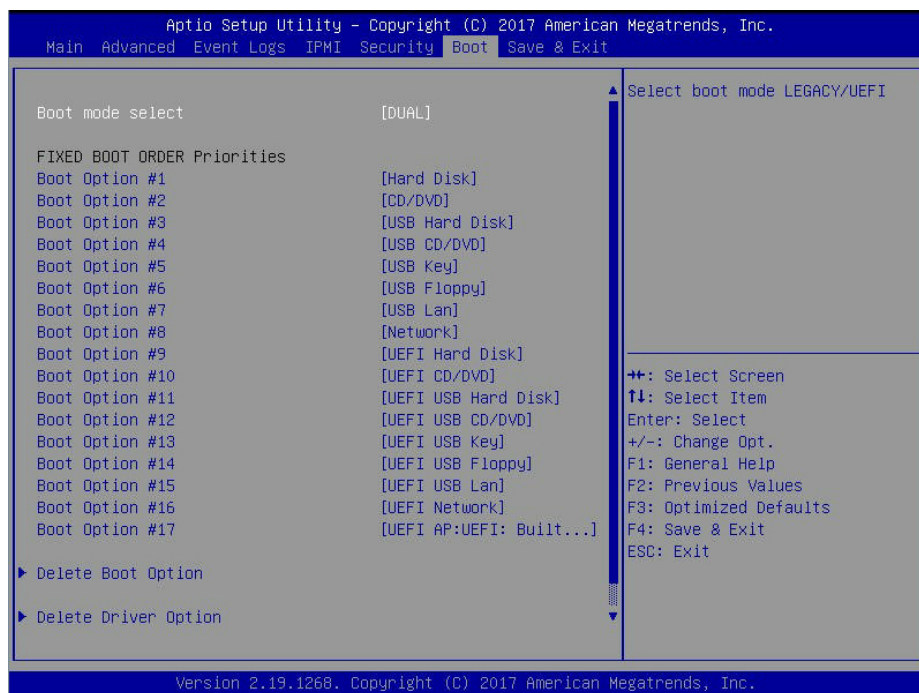

Boot Mode Select

Use this feature to select the type of devices that the system is going to boot from. The options are Legacy, UEFI (Unified Extensible Firmware Interface) and **Dual**.

Fixed Boot Order Priorities

This feature prioritizes the order of a bootable device from which the system will boot. Press <Enter> on each entry from top to bottom to select devices.

When the item above -"Boot Mode Select" is set to **Dual** (default), the following items will be displayed for configuration:

- Boot Option #1 - Boot Option #17

When the item above -"Boot Mode Select" is set to Legacy, the following items will be display for configuration:

- Boot Option #1 - Boot Option #8

When the item above -"Boot Mode Select" is set to UEFI, the following items will be display for configuration:

- Boot Option #1 - Boot Option #9

Add New Boot Option

This feature allows the user to add a new boot option to the boot priority features for your system.

Add Boot Option

Use this item to specify the name for the new boot option.

Path for Boot Option

Use this feature to enter the path for the new boot option in the format fsx:\path\filename.efi.

Boot Option File Path

Use this feature to specify the file path for the new boot option.

Create

After the name and the file path for the boot option are set, press <Enter> to create the new boot option in the boot priority list.

► Delete Boot Option

Use this feature to select a boot device to delete from the boot priority list.

Delete Boot Option

Use this feature to remove an EFI boot option from the boot priority list.

► Delete Driver Option (Currently Unavailable)

Use this item to select a boot driver to delete from the boot priority list.

Delete Drive Option

Select the target boot driver to delete from the boot priority list.

► UEFI Application Boot Priorities

Boot Option #1

Set the system boot order.

6.8 Save & Exit

Select the Save & Exit tab from the BIOS setup screen to configure the settings below.

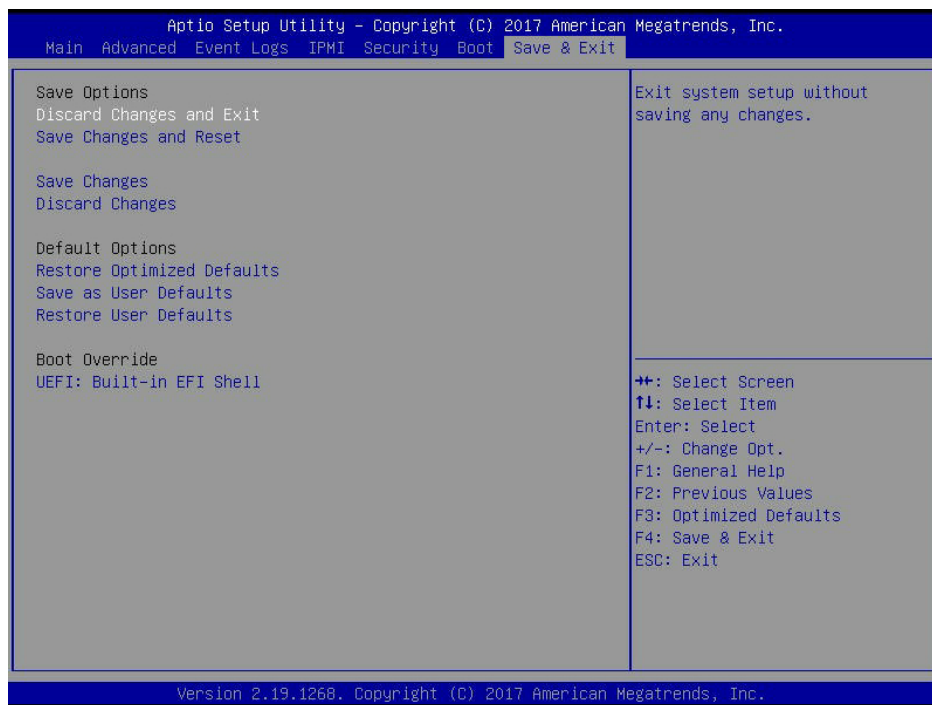

Save Options

Discard Changes and Exit

Select this option to quit the BIOS setup without making any permanent changes to the system configuration and reboot the computer. Select Discard Changes and Exit from the Exit menu and press <Enter>.

Save Changes and Reset

When you have completed the system configuration changes, select this option to leave the BIOS setup utility and reboot the computer for the new system configuration parameters to take effect. Select Save Changes and Exit from the Exit menu and press <Enter>.

Save Changes

When you have completed the system configuration changes, select this option to save all changes made. This will not reset (reboot) the system.

Discard Changes

Select this option and press <Enter> to discard all the changes and return to the AMI BIOS setup utility.

Default Options

Restore Optimized Defaults

To set this feature, select Restore Defaults from the Exit menu and press <Enter> to load manufacturer default settings which are intended for maximum system performance but not for maximum stability.

Save As User Defaults

To set this feature, select Save as User Defaults from the Exit menu and press <Enter>. This enables the user to save any changes to the BIOS setup for future use.

Restore User Defaults

To set this feature, select Restore User Defaults from the Exit menu and press <Enter>. Use this feature to retrieve user-defined settings that were saved previously.

Boot Override

This feature (UEFI: Built-in EFI Shell) allows the user to override the Boot priorities sequence in the Boot menu, and immediately boot the system with a device specified by the user instead of the one specified in the boot list. This is a one-time override.

Appendix A

BIOS Error Codes

A.1 BIOS Error Beep (POST) Codes

During the POST (Power-On Self-Test) routines, which are performed each time the system is powered on, errors may occur.

Non-fatal errors are those which, in most cases, allow the system to continue the boot-up process. The error messages normally appear on the screen.

Fatal errors are those which will not allow the system to continue the boot-up procedure. If a fatal error occurs, you should consult with your system manufacturer for possible repairs.

These fatal errors are usually communicated through a series of audible beeps. The numbers on the fatal error list (on the following page) correspond to the number of beeps for the corresponding error.

BIOS Error Beep (POST) Codes		
Beep Code	Error Message	Description
1 short	Refresh	Circuits have been reset (Ready to power up)
5 short, 1 long	Memory error	No memory detected in system
5 long, 2 short	Display memory read/write error	Video adapter missing or with faulty memory
1 long continuous	System OH	System overheat condition

A-2 Additional BIOS POST Codes

The AMI BIOS supplies additional checkpoint codes, which are documented online at <http://www.supermicro.com/support/manuals/> ("AMI BIOS POST Codes User's Guide").

When BIOS performs the Power On Self Test, it writes checkpoint codes to I/O port 0080h. If the computer cannot complete the boot process, a diagnostic card can be attached to the computer to read I/O port 0080h (Supermicro p/n AOC-LPC80-20).

For information on AMI updates, please refer to <http://www.ami.com/products/>.

Appendix B

Standardized Warning Statements for AC Systems

B.1 About Standardized Warning Statements

The following statements are industry standard warnings, provided to warn the user of situations which have the potential for bodily injury. Should you have questions or experience difficulty, contact Supermicro's Technical Support department for assistance. Only certified technicians should attempt to install or configure components.

Read this appendix in its entirety before installing or configuring components in the Supermicro chassis.

These warnings may also be found on our website at http://www.supermicro.com/about/policies/safety_information.cfm.

Warning Definition



Warning! This warning symbol means danger. You are in a situation that could cause bodily injury. Before you work on any equipment, be aware of the hazards involved with electrical circuitry and be familiar with standard practices for preventing accidents.

警告の定義

この警告サインは危険を意味します。

人身事故につながる可能性がありますので、いずれの機器でも動作させる前に、電気回路に含まれる危険性に注意して、標準的な事故防止策に精通して下さい。

此警告符号代表危險。

您正处于可能受到严重伤害的工作环境中。在您使用设备开始工作之前，必须充分意识到触电的危险，并熟练掌握防止事故发生的标准工作程序。请根据每项警告结尾的声明号码找到此设备的安全性警告说明的翻译文本。

此警告符號代表危險。

您正處於可能身體可能會受損傷的工作環境中。在您使用任何設備之前，請注意觸電的危險，並且要熟悉預防事故發生的標準工作程序。請依照每一注意事項後的號碼找到相關的翻譯說明內容。

Warnung

WICHTIGE SICHERHEITSHINWEISE

Dieses Warnsymbol bedeutet Gefahr. Sie befinden sich in einer Situation, die zu Verletzungen führen kann. Machen Sie sich vor der Arbeit mit Geräten mit den Gefahren elektrischer Schaltungen und den üblichen Verfahren zur Vorbeugung vor Unfällen vertraut. Suchen Sie mit der am Ende jeder Warnung angegebenen Anweisungsnummer nach der jeweiligen Übersetzung in den übersetzten Sicherheitshinweisen, die zusammen mit diesem Gerät ausgeliefert wurden.

BEWAHREN SIE DIESE HINWEISE GUT AUF.

INSTRUCCIONES IMPORTANTES DE SEGURIDAD

Este símbolo de aviso indica peligro. Existe riesgo para su integridad física. Antes de manipular cualquier equipo, considere los riesgos de la corriente eléctrica y familiarícese con los procedimientos estándar de prevención de accidentes. Al final de cada advertencia encontrará el número que le ayudará a encontrar el texto traducido en el apartado de traducciones que acompaña a este dispositivo.

GUARDE ESTAS INSTRUCCIONES.

IMPORTANTES INFORMATIONS DE SÉCURITÉ

Ce symbole d'avertissement indique un danger. Vous vous trouvez dans une situation pouvant entraîner des blessures ou des dommages corporels. Avant de travailler sur un équipement, soyez conscient des dangers liés aux circuits électriques et familiarisez-vous avec les procédures couramment utilisées pour éviter les accidents. Pour prendre connaissance des traductions des avertissements figurant dans les consignes de sécurité traduites qui accompagnent cet appareil, référez-vous au numéro de l'instruction situé à la fin de chaque avertissement.

CONSERVEZ CES INFORMATIONS.

תקנון הזהרות אזהרה

הזהרות הבאות הן אזהרות על פי תקני התעשייה, על מנת להזהיר את המשתמש מפני חבלה פיזית אפשרית. במידה ויש שאלות או היתקלות בבעיה כלשהי, יש ליצור קשר עם מחלקת תמיכה טכנית של סופרמיקרו. טכנאים מוסמכים בלבד רשאים להתקין או להגדיר את הרכיבים. יש לקרוא את הנספח במלואו לפני התקנת או הגדרת הרכיבים במארזי סופרמיקרו.

اَكْ فِ حَالَةٍ وُكِي اَيُّ تَتَسَبَّبُ فِ اِصَابَةِ جَسَدِهِ هَذَا الزَّهْمُ عَ خَطَرٍ! تَحْذَرُ .
قَبْلَ اَيُّ تَعْوَلُ عَلَى اَيُّ هَعْدَاتٍ، كِي عَلَى اَعْلَنَ بِالوَخَاطِزِ اَلْ اَجْوَةِ عِي الذَّوَانِرِ
اَلْكَهْزِبَائِيَّةِ
وَكِي عَلَى دَرَاةٍ بِالوَوَارِسَاتِ النِّقَائِيَّةِ لَوْ عُرِجَ وَقَعَ اَيُّ حَادِثٍ
اَسْتَخْدَمَ رَقْنَ اَلْبِ اِيَّ اَلْوَصُصِ فِ هَآءِ كُلِّ تَحْذَرٍ لِّلْعَثْرِ تَزْجُوْتِهَا

안전을 위한 주의사항

경고!

이 경고 기호는 위험이 있음을 알려 줍니다. 작업자의 신체에 부상을 야기 할 수 있는 상태에 있게 됩니다. 모든 장비에 대한 작업을 수행하기 전에 전기회로와 관련된 위험요소들을 확인하시고 사전에 사고를 방지할 수 있도록 표준 작업절차를 준수해 주시기 바랍니다.

해당 번역문을 찾기 위해 각 경고의 마지막 부분에 제공된 경고문 번호를 참조하십시오

BELANGRIJKE VEILIGHEIDSINSTRUCTIES

Dit waarschuwings symbool betekent gevaar. U verkeert in een situatie die lichamelijk letsel kan veroorzaken. Voordat u aan enige apparatuur gaat werken, dient u zich bewust te zijn van de bij een elektrische installatie betrokken risico's en dient u op de hoogte te zijn van de standaard procedures om ongelukken te voorkomen. Gebruik de nummers aan het eind van elke waarschuwing om deze te herleiden naar de desbetreffende locatie.

BEWAAR DEZE INSTRUCTIES

Installation Instructions



Warning! Read the installation instructions before connecting the system to the power source.

設置手順書

システムを電源に接続する前に、設置手順書をお読み下さい。

警告

将此系统连接电源前,请先阅读安装说明。

警告

將系統與電源連接前，請先閱讀安裝說明。

Warnung

Vor dem Anschließen des Systems an die Stromquelle die Installationsanweisungen lesen.

¡Advertencia!

Lea las instrucciones de instalación antes de conectar el sistema a la red de alimentación.

Attention

Avant de brancher le système sur la source d'alimentation, consulter les directives d'installation.

יש לקרוא את הוראות התקנה לפני חיבור המערכת למקור מתח.

اقرأ إرشادات التركيب قبل توصيل النظام إلى مصدر للطاقة

시스템을 전원에 연결하기 전에 설치 안내를 읽어주십시오.

Waarschuwing

Raadpleeg de installatie-instructies voordat u het systeem op de voedingsbron aansluit.

Circuit Breaker



Warning! This product relies on the building's installation for short-circuit (overcurrent) protection. Ensure that the protective device is rated not greater than: 250 V, 20 A.

サーキット・ブレーカー

この製品は、短絡(過電流)保護装置がある建物での設置を前提としています。

保護装置の定格が250 V、20 Aを超えないことを確認下さい。

警告

此产品的短路(过载电流)保护由建筑物的供电系统提供,确保短路保护设备的额定电流不大于250V,20A。

警告

此產品的短路(過載電流)保護由建築物的供電系統提供,確保短路保護設備的額定電流不大於250V,20A。

Warnung

Dieses Produkt ist darauf angewiesen, dass im Gebäude ein Kurzschluss- bzw. Überstromschutz installiert ist. Stellen Sie sicher, dass der Nennwert der Schutzvorrichtung nicht mehr als: 250 V, 20 A beträgt.

¡Advertencia!

Este equipo utiliza el sistema de protección contra cortocircuitos (o sobrecorrientes) del edificio. Asegúrese de que el dispositivo de protección no sea superior a: 250 V, 20 A.

Attention

Pour ce qui est de la protection contre les courts-circuits (surtension), ce produit dépend de l'installation électrique du local. Vérifiez que le courant nominal du dispositif de protection n'est pas supérieur à :250 V, 20 A.

מוצר זה מסתמך על הגנה המותקנת במבנים למניעת קצר חשמלי. יש לוודא כי המכשיר המגן מפני הקצר החשמלי הוא לא יותר מ-250VDC, 20A

هذا المنتج يعتمد على معدات الحماية من الدوائر القصيرة التي تم تثبيتها في المبنى
تأكد من أن تقييم الجهاز الوقائي ليس أكثر من : 20A, 250V

경고!

이 제품은 전원의 단락(과전류)방지에 대해서 전적으로 건물의 관련 설비에 의존합니다. 보호장치의 정격이 반드시 250V(볼트), 20A(암페어)를 초과하지 않도록 해야 합니다.

Waarschuwing

Dit product is afhankelijk van de kortsluitbeveiliging (overspanning) van uw elektrische installatie. Controleer of het beveiligde apparaat niet groter gedimensioneerd is dan 250V, 20A.

Power Disconnection Warning



Warning! The system must be disconnected from all sources of power and the power cord removed from the power supply module(s) before accessing the chassis interior to install or remove system components.

電源切断の警告

システムコンポーネントの取り付けまたは取り外しのために、シャーシー内部にアクセスするには、システムの電源はすべてのソースから切断され、電源コードは電源モジュールから取り外す必要があります。

警告

在你打开机箱并安装或移除内部器件前,必须将系统完全断电,并移除电源线。

警告

在您打開機殼安裝或移除內部元件前，必須將系統完全斷電，並移除電源線。

Warnung

Das System muss von allen Quellen der Energie und vom Netzanschlusskabel getrennt sein, das von den Spg.Versorgungsteilmodulen entfernt wird, bevor es auf den Chassisinnenraum zurückgreift, um Systemsbestandteile anzubringen oder zu entfernen.

¡Advertencia!

El sistema debe ser disconnected de todas las fuentes de energía y del cable eléctrico quitado de los módulos de fuente de alimentación antes de tener acceso el interior del chasis para instalar o para quitar componentes de sistema.

Attention

Le système doit être débranché de toutes les sources de puissance ainsi que de son cordon d'alimentation secteur avant d'accéder à l'intérieur du chasis pour installer ou enlever des composants de système.

אזהרה מפני ניתוק חשמלי

אזהרה!

יש לנתק את המערכת מכל מקורות החשמל ויש להסיר את כבל החשמלי מהספק לפני גישה לחלק הפנימי של המארז לצורך התקנת או הסרת רכיבים.

يجب فصل انظاؤ من جميع مصادر انطاقت وإزانت سهك انكهرباء من وحدة امداد
انطاقت قېم
انصل إلى امناطق انداخهيت نههيكم نتشيج أو إزانت مكناث الجهاز

경고!

시스템에 부품들을 장착하거나 제거하기 위해서는 새시 내부에 접근하기 전에 반드시 전원 공급장치로부터 연결되어있는 모든 전원과 전기코드를 분리해주어야 합니다.

Waarschuwing

Voordat u toegang neemt tot het binnenwerk van de behuizing voor het installeren of verwijderen van systeem onderdelen, dient u alle spanningsbronnen en alle stroomkabels aangesloten op de voeding(en) van de behuizing te verwijderen

Equipment Installation



Warning! Only trained and qualified personnel should be allowed to install, replace, or service this equipment.

機器の設置

トレーニングを受け認定された人だけがこの装置の設置、交換、またはサービスを許可されていません。

警告

只有经过培训且具有资格的人员才能进行此设备的安装、更换和维修。

警告

只有經過受訓且具資格人員才可安裝、更換與維修此設備。

Warnung

Das Installieren, Ersetzen oder Bedienen dieser Ausrüstung sollte nur geschultem, qualifiziertem Personal gestattet werden.

¡Advertencia!

Solamente el personal calificado debe instalar, reemplazar o utilizar este equipo.

Attention

Il est vivement recommandé de confier l'installation, le remplacement et la maintenance de ces équipements à des personnels qualifiés et expérimentés.

אזהרה!

צוות מוסמך בלבד רשאי להתקין, להחליף את הציוד או לתת שירות עבור הציוד.

والمدربيه لتزكيب واستبدال أو خدمة هذا الجهاز يجب أن يسمح فقط للمظفيه المؤهليه

경고!

훈련을 받고 공인된 기술자만이 이 장비의 설치, 교체 또는 서비스를 수행할 수 있습니다.

Waarschuwing

Deze apparatuur mag alleen worden geïnstalleerd, vervangen of hersteld door geschoold en gekwalificeerd personeel.

Restricted Area



Warning! This unit is intended for installation in restricted access areas. A restricted access area can be accessed only through the use of a special tool, lock and key, or other means of security. (This warning does not apply to workstations).

アクセス制限区域

このユニットは、アクセス制限区域に設置されることを想定しています。

アクセス制限区域は、特別なツール、鍵と錠前、その他のセキュリティの手段を用いてのみ出入りが可能です。

警告

此部件应安装在限制进出的场所，限制进出的场所指只能通过使用特殊工具、锁和钥匙或其它安全手段进出的场所。

警告

此装置仅限安装於進出管制區域，進出管制區域係指僅能以特殊工具、鎖頭及鑰匙或其他安全方式才能進入的區域。

Warnung

Diese Einheit ist zur Installation in Bereichen mit beschränktem Zutritt vorgesehen. Der Zutritt zu derartigen Bereichen ist nur mit einem Spezialwerkzeug, Schloss und Schlüssel oder einer sonstigen Sicherheitsvorkehrung möglich.

¡Advertencia!

Esta unidad ha sido diseñada para instalación en áreas de acceso restringido. Sólo puede obtenerse acceso a una de estas áreas mediante la utilización de una herramienta especial, cerradura con llave u otro medio de seguridad.

Attention

Cet appareil doit être installée dans des zones d'accès réservés. L'accès à une zone d'accès réservé n'est possible qu'en utilisant un outil spécial, un mécanisme de verrouillage et une clé, ou tout autre moyen de sécurité.

אזור עם גישה מוגבלת

אזהרה!

יש להתקין את היחידה באזורים שיש בהם הגבלת גישה. הגישה ניתנת בעזרת 'כלי אבטחה בלבד' (מפתח, מנעול וכד.).

تخصيص هذه انحدة نترك بُها ف مناطق محظورة تم .
،مكن اننصل إن منطقت محظورة فقط من خلال استخذاو أداة خاصت
أو أ وس هُت أخري نلالأمما ققم ومفتاح

경고!

이 장치는 접근이 제한된 구역에 설치하도록 되어있습니다. 특수도구, 잠금 장치 및 키, 또는 기타 보안 수단을 통해서만 접근 제한 구역에 들어갈 수 있습니다.

Waarschuwing

Dit apparaat is bedoeld voor installatie in gebieden met een beperkte toegang. Toegang tot dergelijke gebieden kunnen alleen verkregen worden door gebruik te maken van speciaal gereedschap, slot en sleutel of andere veiligheidsmaatregelen.

Battery Handling



Warning! There is the danger of explosion if the battery is replaced incorrectly. Replace the battery only with the same or equivalent type recommended by the manufacturer. Dispose of used batteries according to the manufacturer's instructions

電池の取り扱い

電池交換が正しく行われなかった場合、破裂の危険性があります。交換する電池はメーカーが推奨する型、または同等のものを使用下さい。使用済電池は製造元の指示に従って処分して下さい。

警告

電池更換不當會有爆炸危險。請只使用同類電池或制造商推薦的功能相當的電池更換原有電池。請按製造商的說明處理廢舊電池。

警告

電池更換不當會有爆炸危險。請使用製造商建議之相同或功能相當的電池更換原有電池。請按照製造商的說明指示處理廢棄舊電池。

Warnung

Bei Einsetzen einer falschen Batterie besteht Explosionsgefahr. Ersetzen Sie die Batterie nur durch den gleichen oder vom Hersteller empfohlenen Batterietyp. Entsorgen Sie die benutzten Batterien nach den Anweisungen des Herstellers.

Attention

Danger d'explosion si la pile n'est pas remplacée correctement. Ne la remplacer que par une pile de type semblable ou équivalent, recommandée par le fabricant. Jeter les piles usagées conformément aux instructions du fabricant.

¡Advertencia!

Existe peligro de explosión si la batería se reemplaza de manera incorrecta. Reemplazar la batería exclusivamente con el mismo tipo o el equivalente recomendado por el fabricante. Desechar las baterías gastadas según las instrucciones del fabricante.

אזהרה!

קיימת סכנת פיצוץ של הסוללה במידה והוחלפה בדרך לא תקינה. יש להחליף את הסוללה בסוג התואם מחברת יצרן מומלצת. סילוק הסוללות המשומשות יש לבצע לפי הוראות היצרן.

هناك خطر من انفجار في حالة اسحبذال البطارية بطريقة غير صحيحة فعليل
اسحبذال البطارية
فقط بنفس النوع أو ما يعادلها مما أوصت به الشركة المصنعة
جخلص من البطاريات المسحمة وفقا لعمليات الشركة الصانعة

경고!

배터리가 올바르게 교체되지 않으면 폭발의 위험이 있습니다. 기존 배터리와 동일하거나 제조사에서 권장하는 동등한 종류의 배터리로만 교체해야 합니다. 제조사의 안내에 따라 사용된 배터리를 처리하여 주십시오.

Waarschuwing

Er is ontploffingsgevaar indien de batterij verkeerd vervangen wordt. Vervang de batterij slechts met hetzelfde of een equivalent type die door de fabrikant aanbevolen wordt. Gebruikte batterijen dienen overeenkomstig fabrieksvoorschriften afgevoerd te worden.

Redundant Power Supplies



Warning! This unit might have more than one power supply connection. All connections must be removed to de-energize the unit.

冗長電源装置

このユニットは複数の電源装置が接続されている場合があります。

ユニットの電源を切るためには、すべての接続を取り外さなければなりません。

警告

此部件连接的电源可能不止一个，必须将所有电源断开才能停止给该部件供电。

警告

此装置连接的电源可能不只一个，必须切断所有电源才能停止对该装置的供电。

Warnung

Dieses Gerät kann mehr als eine Stromzufuhr haben. Um sicherzustellen, dass der Einheit kein Strom zugeführt wird, müssen alle Verbindungen entfernt werden.

¡Advertencia!

Puede que esta unidad tenga más de una conexión para fuentes de alimentación. Para cortar por completo el suministro de energía, deben desconectarse todas las conexiones.

Attention

Cette unité peut avoir plus d'une connexion d'alimentation. Pour supprimer toute tension et tout courant électrique de l'unité, toutes les connexions d'alimentation doivent être débranchées.

אם קיים יותר מספק אחד

אזהרה!

ליחידה יש יותר מחיבור אחד של ספק. יש להסיר את כל החיבורים על מנת לרוקן את היחידה.

قد يكون لهذا الجهاز عدة اتصالات بوحدات امداد الطاقة .

يجب إزالة كافة الاتصالات لعسل الوحدة عن الكهرباء

경고!

이 장치에는 한 개 이상의 전원 공급 단자가 연결되어 있을 수 있습니다. 이 장치에 전원을 차단하기 위해서는 모든 연결 단자를 제거해야만 합니다.

Waarschuwing

Deze eenheid kan meer dan één stroomtoevoeraansluiting bevatten. Alle aansluitingen dienen verwijderd te worden om het apparaat stroomloos te maken.

Backplane Voltage



Warning! Hazardous voltage or energy is present on the backplane when the system is operating. Use caution when servicing.

バックプレーンの電圧

システムの稼働中は危険な電圧または電力が、バックプレーン上にかかっています。

修理する際には注意ください。

警告

当系统正在进行时，背板上有很危险的电压或能量，进行维修时务必小心。

警告

當系統正在進行時，背板上危險的電壓或能量，進行維修時務必小心。

Warnung

Wenn das System in Betrieb ist, treten auf der Rückwandplatine gefährliche Spannungen oder Energien auf. Vorsicht bei der Wartung.

¡Advertencia!

Cuando el sistema está en funcionamiento, el voltaje del plano trasero es peligroso. Tenga cuidado cuando lo revise.

Attention

Lorsque le système est en fonctionnement, des tensions électriques circulent sur le fond de panier. Prendre des précautions lors de la maintenance.

מתח בפנל האחורי

אזהרה!

קיימת סכנת מתח בפנל האחורי בזמן תפעול המערכת. יש להיזהר במהלך העבודה.

هناك خطر من التيار الكهربائي أو الطاقة المتجددة على اللوحة
عندما يكون النظام يعمل كه حذرا عند خدمة هذا الجهاز

경고!

시스템이 동작 중일 때 후면판 (Backplane)에는 위험한 전압이나 에너지가 발생 합니다.
서비스 작업 시 주의하십시오.

Waarschuwing

Een gevaarlijke spanning of energie is aanwezig op de backplane wanneer het systeem in gebruik is. Voorzichtigheid is geboden tijdens het onderhoud.

Comply with Local and National Electrical Codes



Warning! Installation of the equipment must comply with local and national electrical codes.

地方および国の電気規格に準拠

機器の取り付けはその地方および国の電気規格に準拠する必要があります。

警告

设备安装必须符合本地与本国电气法规。

警告

設備安裝必須符合本地與本國電氣法規。

Warnung

Die Installation der Geräte muss den Sicherheitsstandards entsprechen.

¡Advertencia!

La instalación del equipo debe cumplir con las normas de electricidad locales y nacionales.

Attention

L'équipement doit être installé conformément aux normes électriques nationales et locales.

תיאום חוקי החשמל הארצי

אזהרה!

התקנת הציוד חייבת להיות תואמת לחוקי החשמל המקומיים והארציים.

تركيب المعدات الكهربائية يجب أن يمتثل للقوايه المحلية والبطية المتعلقة

بالكهرباء

경고!

현 지역 및 국가의 전기 규정에 따라 장비를 설치해야 합니다.

Waarschuwing

Bij installatie van de apparatuur moet worden voldaan aan de lokale en nationale elektriciteitsvoorschriften.

Product Disposal



Warning! Ultimate disposal of this product should be handled according to all national laws and regulations.

製品の廃棄

この製品を廃棄処分する場合、国の関係する全ての法律・条例に従い処理する必要があります。

警告

本产品的废弃处理应根据所有国家的法律和规章进行。

警告

本產品的廢棄處理應根據所有國家的法律和規章進行。

Warnung

Die Entsorgung dieses Produkts sollte gemäß allen Bestimmungen und Gesetzen des Landes erfolgen.

¡Advertencia!

Al deshacerse por completo de este producto debe seguir todas las leyes y reglamentos nacionales.

Attention

La mise au rebut ou le recyclage de ce produit sont généralement soumis à des lois et/ou directives de respect de l'environnement. Renseignez-vous auprès de l'organisme compétent.

סילוק המוצר

אזהרה!

סילוק סופי של מוצר זה חייב להיות בהתאם להנחיות וחוקי המדינה.

التخلص النهائي من هذا المنتج ينبغي التعامل معه وفقا لجميع القوانين واللوائح الوطنية عند

경고!

이 제품은 해당 국가의 관련 법규 및 규정에 따라 폐기되어야 합니다.

Waarschuwing

De uiteindelijke verwijdering van dit product dient te geschieden in overeenstemming met alle nationale wetten en reglementen.

Hot Swap Fan Warning



Warning! Hazardous moving parts. Keep away from moving fan blades. The fans might still be turning when you remove the fan assembly from the chassis. Keep fingers, screwdrivers, and other objects away from the openings in the fan assembly's housing.

ファン・ホットスワップの警告

警告!回転部品に注意。運転中は回転部(羽根)に触れないでください。シャーシから冷却ファン装置を取り外した際、ファンがまだ回転している可能性があります。ファンの開口部に、指、ドライバー、およびその他のものを近づけないで下さい。

警告!

警告! 危險的可移動性零件。請務必與轉動的风扇叶片保持距離。當您從機架移除風扇裝置，風扇可能仍在轉動。小心不要將手指、螺絲起子和其他物品太靠近風扇

警告

危險的可移動性零件。請務必與轉動的风扇叶片保持距離。當您從機架移除風扇裝置，風扇可能仍在轉動。小心不要將手指、螺絲起子和其他物品太靠近風扇。

Warnung

Gefährlich Bewegende Teile. Von den bewegenden Lüfterblätter fern halten. Die Lüfter drehen sich u. U. noch, wenn die Lüfterbaugruppe aus dem Chassis genommen wird. Halten Sie Finger, Schraubendreher und andere Gegenstände von den Öffnungen des Lüftergehäuses entfernt.

¡Advertencia!

Riesgo de piezas móviles. Mantener alejado de las aspas del ventilador. Los ventiladores podran dar vuelta cuando usted quite el montaje del ventilador del chasis. Mantenga los dedos, los destornilladores y todos los objetos lejos de las aberturas del ventilador

Attention

Pieces mobiles dangereuses. Se tenir a l'écart des lames du ventilateur Il est possible que les ventilateurs soient toujours en rotation lorsque vous retirerez le bloc ventilateur du châssis. Prenez garde à ce que doigts, tournevis et autres objets soient éloignés du logement du bloc ventilateur.

אזהרה!

חלקים נעים מסוכנים. התרחק מלהבי המאוורר בפעולה כאשר מסירים את חלקי המאוורר מהמארז, יתכן והמאווררים עדיין עובדים. יש להרחיק למרחק בטוח את האצבעות וכלי עבודה שונים מהפתחים בתוך המאוורר

تحذير! أجزاء متحركة خطيرة. ابتعد عن شفرات المروحة المتحركة. من الممكن أن المراوح لا تزال تدور عند إزالة كتلة المروحة من الهيكل يجب إبقاء الأصابع ومفكات البراغي وغيرها من الأشياء بعيدا عن الفتحات في كتلة المروحة

경고!

움직이는 위험한 부품. 회전하는 송풍 날개에 접근하지 마세요. 새시로부터 팬 조립품을 제거할 때 팬은 여전히 회전하고 있을 수 있습니다. 팬 조립품 외관의 열려있는 부분들로부터 손가락 및 스크류드라이버, 다른 물체들이 가까이 하지 않도록 배치해 주십시오.

Waarschuwing

Gevaarlijk bewegende onderdelen. Houd voldoende afstand tot de bewegende ventilatorbladen. Het is mogelijk dat de ventilator nog draait tijdens het verwijderen van het ventilatorsamenstel uit het chassis. Houd uw vingers, schroevendraaiers en eventuele andere voorwerpen uit de buurt van de openingen in de ventilatorbehuizing.

Power Cable and AC Adapter



Warning! When installing the product, use the provided or designated connection cables, power cables and AC adapters. Using any other cables and adapters could cause a malfunction or a fire. Electrical Appliance and Material Safety Law prohibits the use of UL or CSA -certified cables (that have UL/CSA shown on the code) for any other electrical devices than products designated by Supermicro only.

電源コードとACアダプター

製品を設置する場合、提供または指定および購入された接続ケーブル、電源コードとACアダプターを該当する地域の条例や安全基準に適合するコードサイズやプラグと共に使用下さい。他のケーブルやアダプタを使用すると故障や火災の原因になることがあります。

電気用品安全法は、ULまたはCSA認定のケーブル(UL/CSEマークがコードに表記)を Supermicro が指定する製品以外に使用することを禁止しています。

警告

安装此产品时,请使用本身提供的或指定的或采购的连接线,电源线和电源适配器。包含遵照当地法规和安全要求的合规的电源线尺寸和插头。使用其它线材或适配器可能会引起故障或火灾。除了Supermicro所指定的产品,电气用品和材料安全法律规定禁止使用未经UL或CSA认证的线材。(线材上会显示UL/CSA符号)。

警告

安裝此產品時,請使用本身提供的或指定的或採購的連接線,電源線和電源適配器。包含遵照當地法規和安全要求的合規的電源線尺寸和插頭。使用其它線材或適配器可能會引起故障或火災。除了Supermicro所指定的產品,電氣用品和材料安全法律規定禁止使用未經UL或CSA認證的線材。(線材上會顯示UL/CSA符號)。

Warnung

Nutzen Sie beim Installieren des Produkts ausschließlich die von uns zur Verfügung gestellten Verbindungskabeln, Stromkabeln und/oder Adapter, die Ihre örtlichen Sicherheitsstandards einhalten. Der Gebrauch von anderen Kabeln und Adapter können Fehlfunktionen oder Feuer verursachen. Die Richtlinien untersagen das Nutzen von UL oder CAS zertifizierten Kabeln (mit UL/CSA gekennzeichnet), an Geräten oder Produkten die nicht mit Supermicro gekennzeichnet sind.

¡Advertencia!

Cuando instale el producto, utilice la conexión provista o designada o procure cables, Cables de alimentación y adaptadores de CA que cumplan con los códigos locales y los requisitos de seguridad, incluyendo el tamaño adecuado del cable y el enchufe. El uso de otros cables y adaptadores podría causar un mal funcionamiento o un incendio. La Ley de Seguridad de Aparatos Eléctricos y de Materiales prohíbe El uso de cables certificados por UL o CSA (que tienen el certificado UL / CSA en el código) para cualquier otros dispositivos eléctricos que los productos designados únicamente por Supermicro.

Attention

Lors de l'installation du produit, utilisez les cables de connection fournis ou désigné ou achetez des cables, cables de puissance et adaptateurs respectant les normes locales et les conditions de securite y compris les tailles de cables et les prises electriques appropries. L'utilisation d'autres cables et adaptateurs peut provoquer un dysfonctionnement ou un incendie. Appareils électroménagers et la Loi sur la Sécurité Matériel interdit l'utilisation de câbles certifiés- UL ou CSA (qui ont UL ou CSA indiqué sur le code) pour tous les autres appareils électriques sauf les produits désignés par Supermicro seulement.

AC כבלים חשמליים ומתאמי

אזהרה!

אשר נרכשו או הותאמו לצורך ההתקנה, ואשר הותאמו לדרישות AC כאשר מתקינים את המוצר, יש להשתמש בכבלים, ספקים ומתאמים הבטיחות המקומיות, כולל מידה נכונה של הכבל והתקע. שימוש בכל כבל או מתאם מסוג אחר, עלול לגרום לתקלה או קצר חשמלי. בהתאם כאשר מופיע עליהם קוד) UL-CSA או ב UL - לחוקי השימוש במכשירי החשמל וחוקי הבטיחות, קיים איסור להשתמש בכבלים המוסמכים ב Supermicro עבור כל מוצר חשמלי אחר, אלא רק במוצר אשר הותאם ע"י (UL/CSA) של

עند تركيب المنتج، قم باستخدام التوصيلات المتوفرة أو المحددة أو قم بشراء الكابلات الكهربائية ومحوّلات التيار المتردد مع الالتزام بقوانين ومتطلبات السلامة المحلية بما في ذلك حجم الموصل والقابس السليم. استخدام أي كابلات ومحوّلات أخرى قد يتسبب في عطل أو حريق. يحظر قانون السلامة للأجهزة الكهربائية والمعدات استخدام الكابلات المعتمدة Supermicro مع أي معدات أخرى غير المنتجات المعينة والمحددة من قبل (UL/CSA) والتي تحمل علامة CSA أو UL من قبل

전원 케이블 및 AC 어댑터

경고! 제품을 설치할 때 현지 코드 및 적절한 굵기의 코드와 플러그를 포함한 안전 요구 사항을 준수하여 제공되거나 지정된 연결 혹은 구매 케이블, 전원 케이블 및 AC 어댑터를 사용하십시오.

다른 케이블이나 어댑터를 사용하면 오작동이나 화재가 발생할 수 있습니다. 전기 용품 안전법은 UL 또는 CSA 인증 케이블 (코드에 UL / CSA가 표시된 케이블)을 Supermicro가 지정한 제품 이외의 전기 장치에 사용하는 것을 금지합니다.

Stroomkabel en AC-Adapter

Waarschuwing! Bij het aansluiten van het Product uitsluitend gebruik maken van de geleverde Kabels of een andere geschikte aan te schaffen Aansluitmethode, deze moet altijd voldoen aan de lokale voorschriften en veiligheidsnormen, inclusief de juiste kabeldikte en stekker. Het gebruik van niet geschikte Kabels en/of Adapters kan een storing of brand veroorzaken. Wetgeving voor Elektrische apparatuur en Materiaalveiligheid verbied het gebruik van UL of CSA -gecertificeerde Kabels (met UL/CSA in de code) voor elke andere toepassing dan de door Supermicro hiervoor beoogde Producten.

Appendix C

System Specifications

Processors

Dual Intel Xeon 81xx/61xx/51xx/41xx/31xx series or 82xx/62xx/52xx/42xx/32xx series processors in a Socket P type socket

Note: Please refer to the motherboard specifications pages on our website for updates to supported processors.

Chipset

Intel PCH C621 chipset

BIOS

256 Mb SPI AMI® BIOS Flash ROM

Memory

Sixteen DIMM slots support up to 4TB of DDR4-2933 ECC 3DS LRDIMM or ECC RDIMM

Note: See the memory section in Chapter 3 for details and our website for updates to supported memory.

SATA Controller

On-chip (Intel PCH C621) controller

Drive Bays

Two bays support 2.5" SAS/SATA3 drives, two hybrid bays support 2.5" SAS/SATA3/NVMe drives (all are hot-swap)

PCI Expansion Slots

Up to three PCI-E 3.0 slots (see table on page 12 for details)

Motherboard

X11DPG-SN; (13.1 x 14.7 in. / 333 x 373 mm.)

Chassis

SC118GHTS-R1K66BP2; 1U Rackmount, (WxHxD) 17.2 x 1.7 x 30.6 in. (437 x 43 x 777 mm)

System Cooling

Ten 4-cm counter-rotating PWM fans

Power Supply

Model: PWS-1K66P-1R

AC Input Voltages: 100-240 VAC

Rated Input Current: 110-127V: 12.9A max., 200-240V: 9.5A max.

Rated Input Frequency: 50-60 Hz

Rated Output Power: 1600W

Rated Output Voltages: 100-127V: +12V (82A), +12Vsb (2A), 200-240V: +12V (132A), +12Vsb (2A)

Operating Environment

Operating Temperature: 10° to 35° C (50° to 95° F)

Non-operating Temperature: -40° to 60° C (-40° to 140° F)

Operating Relative Humidity: 8% to 90% (non-condensing)

Non-operating Relative Humidity: 5% to 95% (non-condensing)

Regulatory Compliance

Electromagnetic Emissions: FCC Class A, EN 55032 Class A, EN 61000-3-2/3-3, CISPR 32 Class A

Electromagnetic Immunity: EN 55024/CISPR 24, (EN 61000-4-2, EN 61000-4-3, EN 61000-4-4, EN 61000-4-5, EN 61000-4-6, EN 61000-4-8, EN 61000-4-11)

Safety: CSA/EN/IEC/UL 60950-1 Compliant, UL or CSA Listed (USA and Canada), CE Marking (Europe)

Other: VCCI-CISPR 32 and AS/NZS CISPR 32

Environmental: Directive 2011/65/EU, Delegated Directive (EU) 2015/863 and Directive 2012/19/EU

Perchlorate Warning

California Best Management Practices Regulations for Perchlorate Materials: This Perchlorate warning applies only to products containing CR (Manganese Dioxide) Lithium coin cells. "Perchlorate Material-special handling may apply. See www.dtsc.ca.gov/hazardouswaste/perchlorate"

Appendix D

CPU-Based RAID for NVMe

Intel® Virtual RAID on CPU (Intel VROC) is an enterprise RAID solution for NVMe SSDs directly attached to Intel Xeon Scalable processors. Intel Volume Management Device (VMD) is an integrated controller inside the CPU PCI-E root complex.

- A single processor supports up to 12 NVMe SSDs and up to 6 RAID arrays.
- A dual processor system supports up to 24 NVMe SSDs and 12 RAID arrays.

Strip sizes are 4K, 8K, 16K, 32K, 64K, 128K.

Requirements and Restrictions

- **Intel VROC is only available when the system is configured for UEFI boot mode.**
- To enable the `mdadm` command and support for RSTe, install the patch from
 - Linux: <https://downloadcenter.intel.com/download/28158/Intel-Virtual-RAID-on-CPU-Intel-VROC-and-Intel-Rapid-Storage-Technology-enterprise-Intel-RSTe-Driver-for-Linux->
 - Windows: <https://downloadcenter.intel.com/download/28108/Intel-Virtual-RAID-on-CPU-Intel-VROC-and-Intel-Rapid-Storage-Technology-enterprise-Intel-RSTe-Driver-for-Windows->
- To enable Intel VROC, a hardware key must be inserted on the motherboard, and the appropriate processor's Virtual Management Devices must be enabled in the BIOS setup.
- It is possible to enable Intel VROC without a hardware key installed, but only RAID0 will be enabled.
- Intel VROC is not compatible with secure boot. This feature must be disabled.
- When creating bootable OS RAID1 devices, you must have both devices on the same CPU, and a VMD on that CPU.
- Spanning drives when creating RAID devices is not recommended to due to performance issues, even though it is supported.

Supported SSDs and Operating Systems

To see the latest support information: <https://www.intel.com/content/www/us/en/support/articles/000030310/memory-and-storage/ssd-software.html>

Additional Information

Additional information is available on the product page for the Supermicro add-on card and the linked manuals.

www.supermicro.com/products/accessories/addon/AOC-VROCxxxMOD.cfm

D.1 Hardware Key

The Intel VROC hardware key is a license key that detects the Intel VROC SKU and activates the function accordingly. The key must be plugged into the Supermicro motherboard (connector JRK1). The key options are:

Intel® VROC Keys			
VROC Package	Description	Part Number	Intel MM Number
Standard	RAID 0, 1, 10 Supports 3rd party SSDs	AOC-VROCSTNMOD	951605
Premium	RAID 0, 1, 5, 10 Supports 3rd party SSDs	AOC-VROCPREMOD	951606
Intel SSD only	RAID 0, 1, 5, 10 Supports Intel SSDs only	AOC-VROCINTMOD	956822

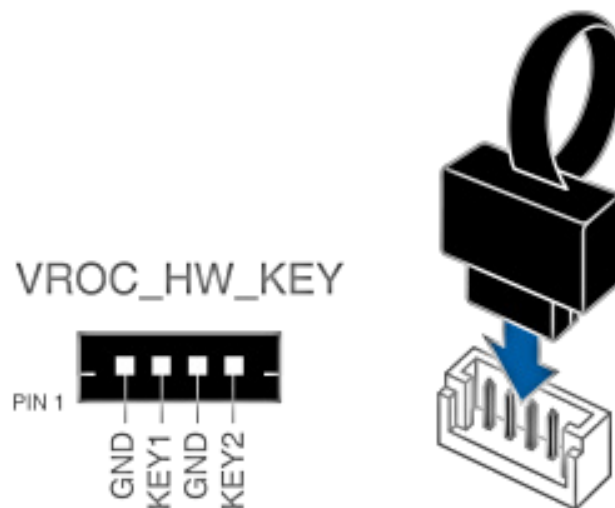

Figure D-1. Intel® VROC RAID Key and Motherboard Connector JRK1

D.2 Enabling NVMe RAID

RAID for NVMe SSDs must be enabled through the UEFI BIOS.

1. Install the patch as described in the Restrictions and Requirements section on a previous page.
2. Reboot the server.
3. Press [DEL] key to enter BIOS.
4. Switch to **Advanced > Chipset Configuration > North Bridge > IIO Configuration > Intel® VMD Technology > CPU1 & CPU2**.
5. **Enable** the VMD according to the following rules.
 - For U.2 NVMe, enable all the sub-items under each PStack, based on the your model server:

VMD BIOS Setting for 1029GP-TR	
CPU1	CPU2
VMD Config for PStack0	VMD Config for PStack1

- For M.2 NVMe or NVMe AIC, enable the VMD according to which AOC card/slot it used.

An example U.2 configuration follows.

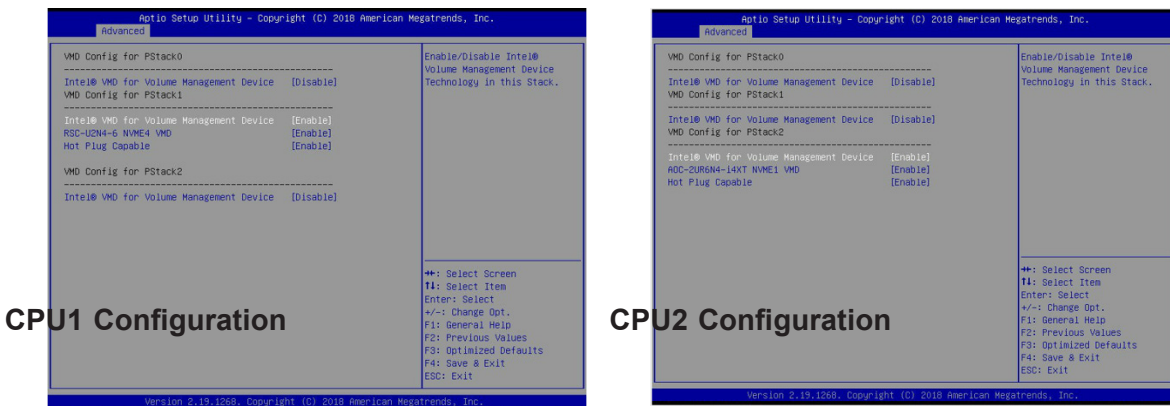

Figure D-2. BIOS VMD Setting Example for 24 Drives

6. Press [F4] to save the configuration and reboot the system.
7. Press [DEL] to enter BIOS.
8. Switch to **Advanced > Intel® Virtual RAID on CPU > All Intel VMD Controllers > Create RAID Volume**.
9. Set **Name**.
10. Set **RAID Level**.
11. If cross-controller RAID is required, select **Enable RAID spanned over VMD Controller** as shown in Figure F-4.

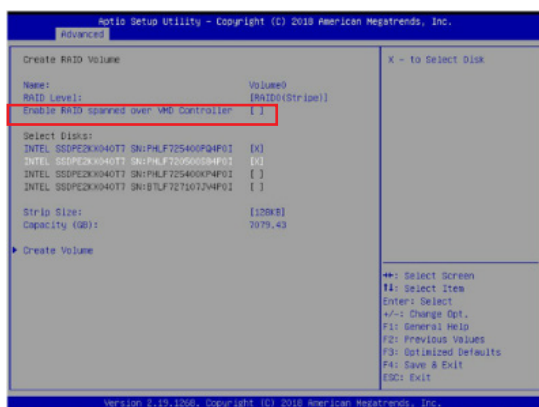

Figure D-3. Created Volume *without* enabling RAID spanned over VMD controller

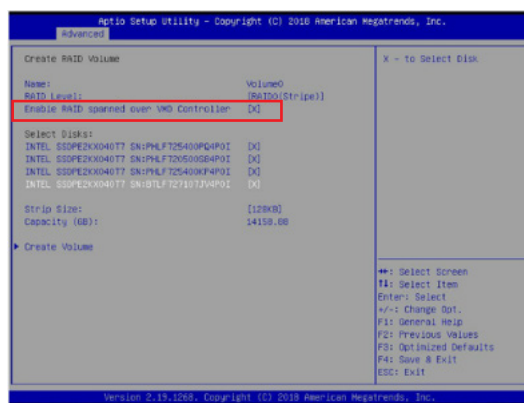

Figure D-4. Created Volume *with* enabling RAID spanned over VMD controller

12. Select specific disks for RAID with an [X].
 - RAID0: Select at least two [2 - 24] disks
 - RAID1: Select only two disks
 - RAID5: Select at least three [3 - 24] disks
 - RAID10: Select only four disks
13. Select **Strip Size** (Default 64KB).
14. Select **Create Volume**.
15. If another RAID is needed, start again at step 6.
16. Press [F4] to save and reboot.

D.3 Status Indications

An LED indicator on the drive carrier shows the RAID status of the drive.

Drive Carrier Status LED Indicator	
Status	State (red)
Normal function	Off
Locating	4 Hz blink
Fault	Solid on
Rebuilding	1 Hz Blink

IBPI SFF 8489 Defined Status LED States

D.4 Hot Swap Drives

Intel VMD enables hot-plug and hot-unplug for NVMe SSDs, whether from Intel or other manufacturers. Under vSphere ESXi, several steps are necessary to avoid potential stability issues. See the information at link [1] below.

Hot-unplug

1. Prevent devices from being re-detected during rescan:

```
esxcli storage core claiming autoclaim --enabled=false
```

2. Unmount the VMFS volumes on the device. Check [2] for details.
3. Detach the device. Check [3] for details.
4. Physically remove the device.

Hot-plug

- Physically install the device.

ESXi will automatically discover NVMe SSDs, but a manual scan may be required in some cases.

Related Information Links

[1] <https://kb.vmware.com/s/article/2151404>

[2] <https://docs.vmware.com/en/VMware-vSphere/6.5/com.vmware.vsphere.storage.doc/GUID-1B56EF97-F60E-4F21-82A7-8F2A7294604D.html>

[3] <https://docs.vmware.com/en/VMware-vSphere/6.5/com.vmware.vsphere.storage.doc/GUID-F2E75F67-740B-4406-9F0C-A2D99A698F2A.html>