



SuperWorkstation®
SYS-532AW-C

USER'S MANUAL

Revision 1.0 MNL-2794

The information in this User's Manual has been carefully reviewed and is believed to be accurate. The vendor assumes no responsibility for any inaccuracies that may be contained in this document, and makes no commitment to update or to keep current the information in this manual, or to notify any person or organization of the updates. Note: For the most up-to-date version of this manual, see our website at <https://www.supermicro.com>.

Super Micro Computer, Inc. ("Supermicro") reserves the right to make changes to the product described in this manual at any time and without notice. This product, including software and documentation, is the property of Supermicro and/or its licensors, and is supplied only under a license. Any use or reproduction of this product is not allowed, except as expressly permitted by the terms of said license.

IN NO EVENT WILL Super Micro Computer, Inc. BE LIABLE FOR DIRECT, INDIRECT, SPECIAL, INCIDENTAL, SPECULATIVE OR CONSEQUENTIAL DAMAGES ARISING FROM THE USE OR INABILITY TO USE THIS PRODUCT OR DOCUMENTATION, EVEN IF ADVISED OF THE POSSIBILITY OF SUCH DAMAGES. IN PARTICULAR, SUPER MICRO COMPUTER, INC. SHALL NOT HAVE LIABILITY FOR ANY HARDWARE, SOFTWARE, OR DATA STORED OR USED WITH THE PRODUCT, INCLUDING THE COSTS OF REPAIRING, REPLACING, INTEGRATING, INSTALLING OR RECOVERING SUCH HARDWARE, SOFTWARE, OR DATA.

Any disputes arising between manufacturer and customer shall be governed by the laws of Santa Clara County in the State of California, USA. The State of California, County of Santa Clara shall be the exclusive venue for the resolution of any such disputes. Supermicro's total liability for all claims will not exceed the price paid for the hardware product.

FCC Statement: This equipment has been tested and found to comply with the limits for a Class A or Class B digital device pursuant to Part 15 of the FCC Rules. These limits are designed to provide reasonable protection against harmful interference when the equipment is operated in industrial environment for Class A device or in residential environment for Class B device. This equipment generates, uses, and can radiate radio frequency energy and, if not installed and used in accordance with the manufacturer's instruction manual, may cause harmful interference with radio communications. Operation of this equipment in a residential area is likely to cause harmful interference, in which case you will be required to correct the interference at your own expense.

California Best Management Practices Regulations for Perchlorate Materials: This Perchlorate warning applies only to products containing CR (Manganese Dioxide) Lithium coin cells. "Perchlorate Material-special handling may apply. See <https://www.dtsc.ca.gov/hazardouswaste/perchlorate>".



WARNING: This product can expose you to chemicals including lead, known to the State of California to cause cancer and birth defects or other reproductive harm. For more information, go to <https://www.P65Warnings.ca.gov>.



AVERTISSEMENT : Ce produit peut vous exposer à des agents chimiques, y compris le plomb, identifié par l'État de Californie comme pouvant causer le cancer, des malformations congénitales ou d'autres troubles de la reproduction. Pour de plus amples informations, prière de consulter <https://www.P65Warnings.ca.gov>.

The products sold by Supermicro are not intended for and will not be used in life support systems, medical equipment, nuclear facilities or systems, aircraft, aircraft devices, aircraft/emergency communication devices or other critical systems whose failure to perform be reasonably expected to result in significant injury or loss of life or catastrophic property damage. Accordingly, Supermicro disclaims any and all liability, and should buyer use or sell such products for use in such ultra-hazardous applications, it does so entirely at its own risk. Furthermore, buyer agrees to fully indemnify, defend and hold Supermicro harmless for and against any and all claims, demands, actions, litigation, and proceedings of any kind arising out of or related to such ultra-hazardous use or sale.

Manual Revision 1.0

Release Date: March 10, 2025

Unless you request and receive written permission from Super Micro Computer, Inc., you may not copy any part of this document. Information in this document is subject to change without notice. Other products and companies referred to herein are trademarks or registered trademarks of their respective companies or mark holders.

Copyright © 2025 by Super Micro Computer, Inc.
All rights reserved.

Published in the United States of America

Preface

About This Manual

This manual is written for professional system integrators and PC technicians. It provides information for the installation and use of the SYS-532AW-C workstation. Installation and maintenance should be performed by certified service technicians only.

Notes

For your system to work properly, follow the links below to download all necessary drivers/utilities and the user's manual for your server.

- Supermicro product manuals: <https://www.supermicro.com/support/manuals>
- Product drivers and utilities: <https://www.supermicro.com/wdl>
- Product safety info: https://www.supermicro.com/about/policies/safety_information.cfm
- A secure data deletion tool designed to fully erase all data from storage devices can be found on our website:
https://www.supermicro.com/about/policies/disclaimer.cfm?url=/wdl/utility/Lot9_Secure_Data_Deletion_Utility
- Frequently Asked Questions: <https://www.supermicro.com/FAQ/index.php>
- If you still have questions after referring to our FAQs, contact our support team. Region-specific Technical Support email addresses can be found at: "[Contacting Supermicro](#)" on page 11
- If you have any feedback on Supermicro product manuals, contact our writing team at: Techwriterteam@supermicro.com

This manual may be periodically updated without notice. Check the Supermicro website for possible updates to the manual revision level.

Conventions Used in the Manual

Special attention should be given to the following symbols for proper installation and to prevent damage done to the components or injury to yourself.



Warning! Indicates important information given to prevent equipment/property damage or personal injury.



Warning! Indicates high voltage may be encountered while performing a procedure.

Important: Important information given to ensure proper system installation or to relay safety precautions.

Note: Additional information given to differentiate various models or to provide information for proper system setup.

Contents

Contacting Supermicro	11
Chapter 1: Introduction	12
1.1 Overview	13
1.2 System Features	15
Front View	15
Control Panel	16
Rear View	17
Side View	18
1.3 System Architecture	19
Motherboard Block Diagram	19
1.4 Motherboard Quick Reference	20
Motherboard Layout	20
Quick Reference Table	22
Chapter 2: Workstation Installation	25
2.1 Unpacking the System	26
2.2 Preparing for Setup	27
Choosing a Setup Location	27
System Precautions	27
Chapter 3: Maintenance and Component Installation	28
3.1 Removing Power	30
3.2 Accessing the System	31
Removing the Side Cover	31
Removing the Front Bezel	32
3.3 Static-Sensitive Devices	33
Precautions	33
3.4 Processor and Heatsink Installation	34
Installing an LGA 1851 Processor	35
Installing a Processor Heatsink	38
Removing the Processor Heatsink	41
3.5 Memory	42
Memory Support	42

Memory Population Table	42
Memory Support Table	42
General Guidelines for Optimizing Memory Performance	43
DIMM Installation	44
DIMM Removal	46
M.2 Device Installation	47
Installing a Standard M.2 Device	47
Installing an M.2 Device with Heatsink (Optional)	49
PCI Expansion Card Installation	52
Installing an Expansion Card	52
3.6 Motherboard Battery Removal and Installation	53
Battery Removal	53
Proper Battery Disposal	53
Battery Installation	53
3.7 Storage Drives	54
3.8 System Cooling	55
Fans	55
Replacing the Rear Fan	56
Replacing the Front Fan	56
Dust Filters	57
3.9 Power Supply	58
Replacing the Power Supply	58
Chapter 4: Motherboard Connections, Jumpers, and LEDs	59
4.1 Power Connections	61
ATX Power Supply Connection	61
4.2 Headers and Connections	63
COM Header	63
DOM Power Connector	63
Fan Headers	64
Front Panel Audio Header	64
Internal Speaker/Buzzer	65
M.2 M-Key PCIe 5.0/4.0 x4 Slots	65
Power LED Header	65
Pump Power Header	66

SATA 3.0 Ports	66
SlimSAS 8i Connector	66
Standby Power	67
TPM/Port 80 Header	67
USB Headers	68
4.3 Rear I/O Ports	70
DisplayPort	71
HDMI Port	71
USB Ports	71
High Definition Audio (HD Audio) Ports	71
4.4 Jumper Settings	73
CMOS Clear	73
CPU PCIe SLOT3 1x8/2x4	74
External Speaker / Buzzer	74
HD Audio Enable/Disable	74
LAN Enable/Disable	75
ME Manufacturing Mode	75
Onboard TPM Enable/Disable	75
Watchdog Timer	76
4.5 LED Indicators	77
CATERR LED	77
Onboard Power LED	77
Standby Power	78
Chapter 5: Software	79
5.1 Microsoft Windows OS Installation	80
Installing the OS	80
5.2 Driver Installation	82
Chapter 6: Optional Components	84
6.1 Optional Parts List	85
Chapter 7: Troubleshooting and Support	86
7.1 Online Resources	87
Direct Links for the SYS-532AW-C System	87
Direct Links for General Support and Information	87
7.2 Troubleshooting Procedures	88

Before Power On	88
No Power	88
No Video	88
System Boot Failure	88
Memory Errors	89
Losing the System's Setup Configuration	89
If the System Becomes Unstable	89
7.3 CMOS Clear	91
7.4 Motherboard Battery	92
7.5 Where to Get Replacement Components	93
7.6 Technical Support Procedures	94
Returning Merchandise for Service	94
7.7 Feedback	96
Chapter 8: UEFI BIOS	97
8.1 Introduction	98
Updating BIOS	98
Starting the Setup Utility	98
8.2 Main Setup	100
8.3 Advanced Setup Configurations	102
ACPI Settings Menu	103
Boot Feature Menu	104
CPU Configuration Menu	106
Chipset Configuration Menu	110
System Agent (SA) Configuration Menu	110
Memory Configuration Menu	110
Graphics Configuration Menu	111
DMI Configuration Menu	112
PEG Port Configuration	112
GT - Power Management Control	113
PCH-IO Configuration Menu	114
PCI Express Configuration	114
HTTP Boot Configuration Menu	115
Super IO Configuration Menu	116
Serial Port 1 Configuration Menu	116

Network Stack Configuration Menu	116
MAC:(MAC address)-IPv4 Network Configuration Menu	117
MAC:(MAC address)-IPv6 Network Configuration Menu	118
MAC:(MAC address)-IPv4 Network Configuration Menu	119
MAC:(MAC address)-IPv6 Network Configuration Menu	120
PCH-FW Configuration	121
AMT Configuration	121
ASF Configuration	122
Secure Erase Configuration	122
One Click Recovery (OCR) Configuration	122
PCIe/PCI/PnP Configuration Menu	123
SATA and RST Configuration	124
VMD Setup Menu	125
Serial Port Console Redirection Menu	126
Trusted Computing Menu	129
USB Configuration	131
Intel(R) Ethernet Connection (19) I219-V - (MAC address) Menu	131
Intel Ethernet Controller I226-LM - (MAC address) Menu	132
TLS Authenticate Configuration Menu	132
Intel(R) Rapid Storage Technology Menu	133
Driver Health Menu	135
8.4 Event Logs	136
8.5 Security	138
Secure Boot Menu	139
Supermicro Security Erase Configuration Menu	142
8.6 Boot	144
8.7 Save & Exit	146
8.8 MEBx	148
Appendix A: BIOS Codes	149
BIOS Error POST (Beep) Codes	149
Additional BIOS POST Codes	149
Appendix B: Standardized Warning Statements for AC Systems	150
Warning Definition	150
Installation Instructions	152

Circuit Breaker	153
Power Disconnection Warning	155
Equipment Installation	156
Restricted Area	158
Battery Handling	159
Redundant Power Supplies	161
Backplane Voltage	162
Comply with Local and National Electrical Codes	164
Product Disposal	165
Fan Warning	166
Power Cable and AC Adapter	168
Appendix C: System Specifications	172

Contacting Supermicro

Headquarters

Address: Super Micro Computer, Inc.
980 Rock Ave.
San Jose, CA 95131 U.S.A.

Tel: +1 (408) 503-8000

Fax: +1 (408) 503-8008

Email: Marketing@supermicro.com (General Information)
Sales-USA@supermicro.com (Sales Inquiries)
Government_Sales-USA@supermicro.com (Gov. Sales Inquiries)
Support@supermicro.com (Technical Support)
RMA@Supermicro.com (RMA Support)
Webmaster@supermicro.com (Webmaster)

Website: <https://www.supermicro.com>

Europe

Address: Super Micro Computer B.V.
Het Sterrenbeeld 28, 5215 ML
's-Hertogenbosch, The Netherlands

Tel: +31 (0) 73-6400390

Fax: +31 (0) 73-6416525

Email: Sales_Europe@supermicro.com (Sales Inquiries)
Support_Europe@supermicro.com (Technical Support)
RMA_Europe@supermicro.com (RMA Support)

Website: <https://www.supermicro.nl>

Asia-Pacific

Address: Super Micro Computer, Inc.
3F, No. 150, Jian 1st Rd.
Zhonghe Dist., New Taipei City 235 Taiwan (R.O.C)

Tel: +886 (2) 8226-3990

Fax: +886 (2) 8226-3992

Email: Sales-Asia@supermicro.com.tw (Sales Inquiries)
Support@supermicro.com.tw (Technical Support)
RMA@supermicro.com.tw (RMA Support)

Website: <https://www.supermicro.com.tw>

Chapter 1:

Introduction

This chapter provides a brief outline of the functions and features of the SYS-532AW-C system. It is based on the X14SAE motherboard and the CSE-GS3A chassis.

1.1 Overview	13
1.2 System Features	15
Front View	15
Rear View	17
Side View	18
1.3 System Architecture	19
Motherboard Block Diagram	19
1.4 Motherboard Quick Reference	20
Motherboard Layout	20
Quick Reference Table	22

1.1 Overview

This chapter provides a brief outline of the functions and features of the SuperWorkstation SYS-532AW-C. The following provides an overview of the system specifications and capabilities.

System Overview	
Motherboard	X14SAE
Chassis	CSE-GS3A
Processor	Intel® Core™ Ultra 9/7/5 Processors Single Socket V1 (LGA-1851) supported, CPU TDP supports up to 125 W TDP
Memory	Four DDR5 ECC/Non-ECC UDIMM slots, up to 192 GB of memory with speeds of up to 5600 MT/s (1DPC)
Drive Support	Internal drive bays: Two 3.5" drive bays and six 2.5" drive bays Two M.2 M-Key NVMe slots (one Gen5 from the CPU, 2280; one Gen4 from PCH support 2280, 22110) One SlimSAS x8 connector supports two optional PCIe Gen4 NVMe SSDs
Expansion Slots	Two PCIe 5.0 x16 (16/NA or 8/8) One PCIe 4.0 x4 from the CPU
I/O Ports	Front: One USB 3.2 Gen 2 port (20 Gb, Type-C) Two USB 3.2 Gen 1 ports (5 Gb, Type-A) One audio jack Rear: One DisplayPort 2.1 One HDMI 2.1 One Thunderbolt 4 port (40 Gb, Type-C) Three USB 3.2 Gen 2x1 ports (10 Gb, Type-A) One USB 3.2 Gen 2x2 port (20 Gb, Type-C) One Intel Ethernet i219-LM (1 GbE LAN) (for AMT/vPro) One Intel Ethernet i226-LM (2.5 GbE LAN port) One HD Audio 7.1 channel connector with SPDIF optical
System Cooling	One 120-mm rear exhaust fan Three 120-mm front cooling fans
Power	1000 W Multi-Output 80Plus Gold power supply
Form Factor	Mid-tower; (DxWxH) 430 x 205 x 450 mm

Notes:

- The following safety models associated with the SYS-532AW-C have been certified as compliant with UL or CSA: GS3A-10; GS3A-S10X14

1.2 System Features

The following views of the system display the main features. Refer to the System Specifications appendix of this manual for additional specifications.

Front View

The following features are located on the front of the SYS-532AW-C workstation.

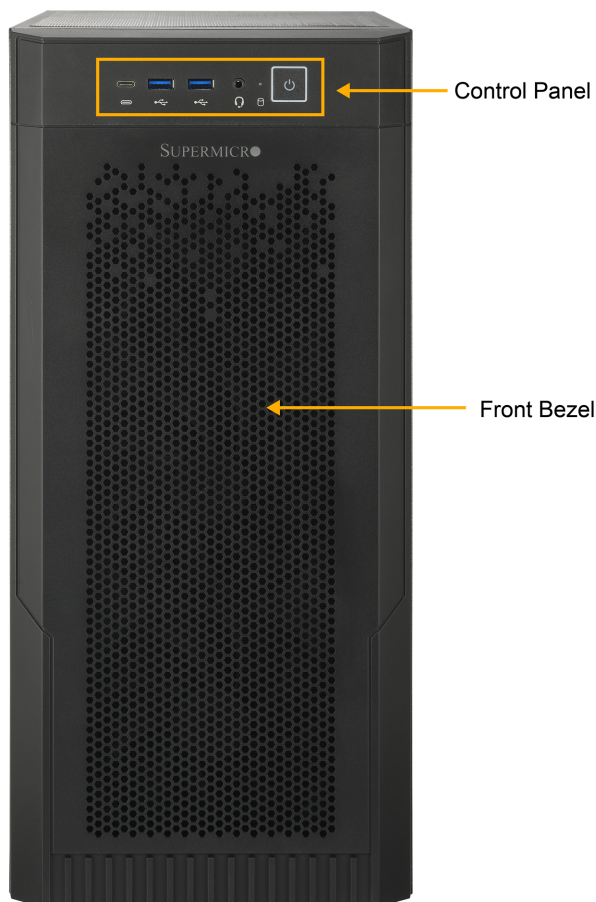

Figure 1-1. SYS-532AW-C Front View

System Features: Front	
Feature	Description
Control Panel	See " Control Panel " on the next page for details.
Front Bezel	Vented bezel with a filter that opens for access to front fans.

Control Panel

The following switches and LEDs are located on the SYS-532AW-C workstation control panel.

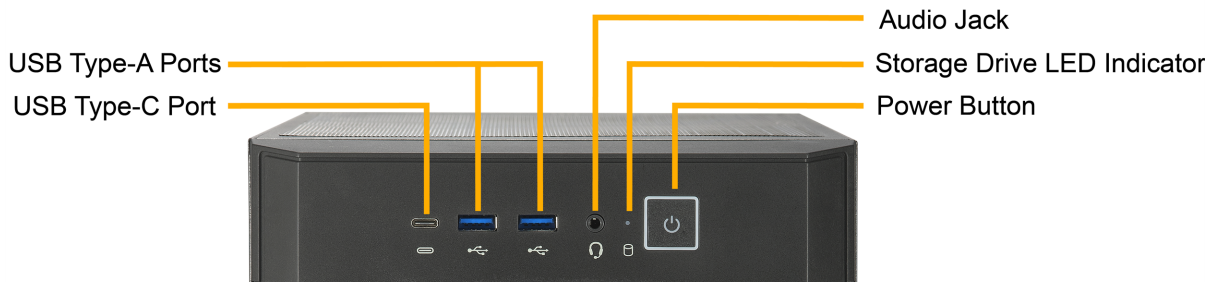

Figure 1-2. SYS-532AW-C Control Panel

Control Panel Features	
Feature	Description
USB Type-C Port	One USB 3.2 Gen 2 port (20 G)
USB Type-A Ports	Two USB 3.2 Gen 1 ports (5 G)
Audio Jack	Combo microphone input / audio output port
Storage Drive LED Indicator	LED that indicates the status of the storage drive
Power Button	Button to power the system on/off with LED

Rear View

The following features are located on the rear of the SYS-532AW-C workstation.

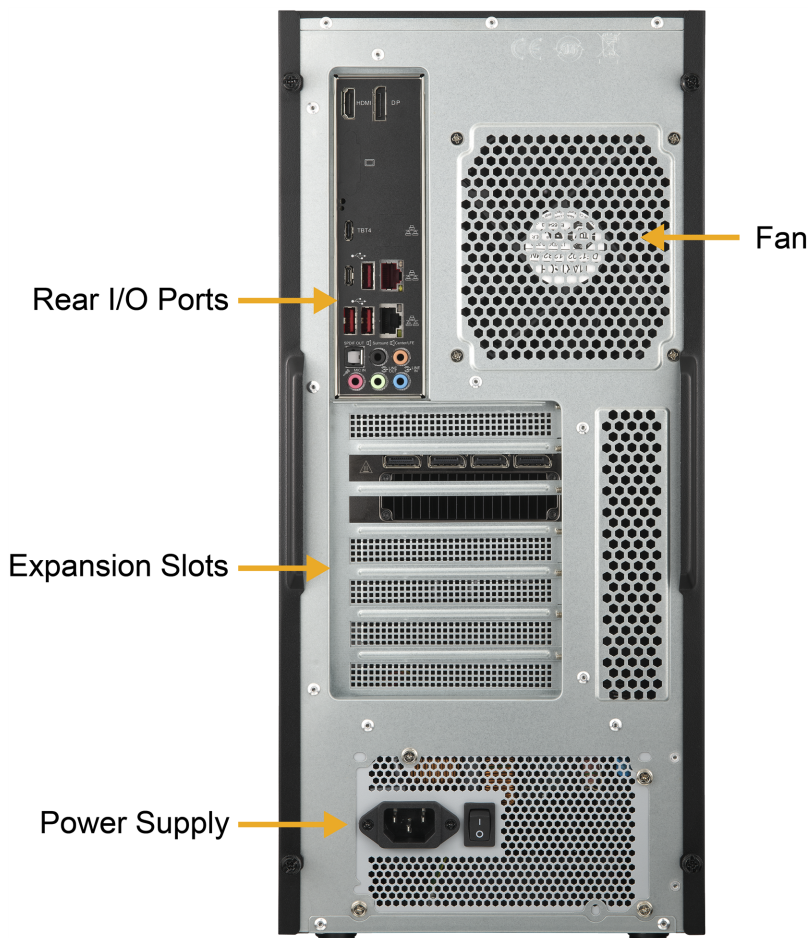

Figure 1-3. SYS-532AW-C Rear View

System Features: Rear	
Feature	Description
Fan	One 120-mm rear exhaust fan
Rear I/O Ports	See " Rear I/O Ports " on page 70 for details
Expansion Slots	Two PCIe 5.0 x16 expansion slots and one PCIe 4.0 x4 expansion slot
Power Supply	One 1000 W Multi-Output 80Plus Gold power supply

Side View

The following features are located on the side of the SYS-532AW-C workstation.

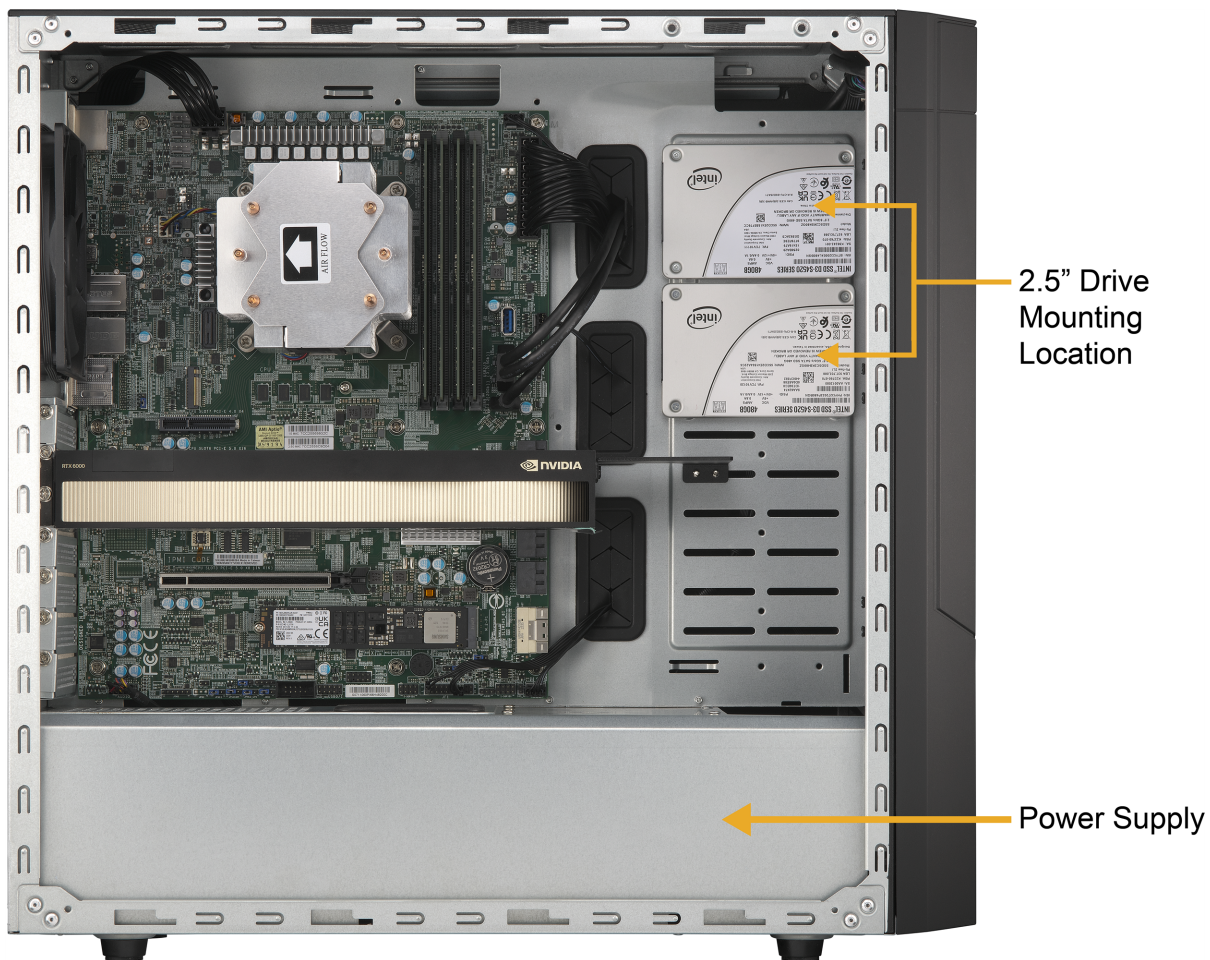

Figure 1-4. SYS-532AW-C Side View

System Features: Side	
Feature	Description
2.5" Drive Mounting Location	Two 2.5" drives can be mounted at this location
Power Supply	One 1000 W Multi-Output 80Plus Gold Power Supply

1.3 System Architecture

This section covers the locations of the system's main components and provides a system block diagram.

Motherboard Block Diagram

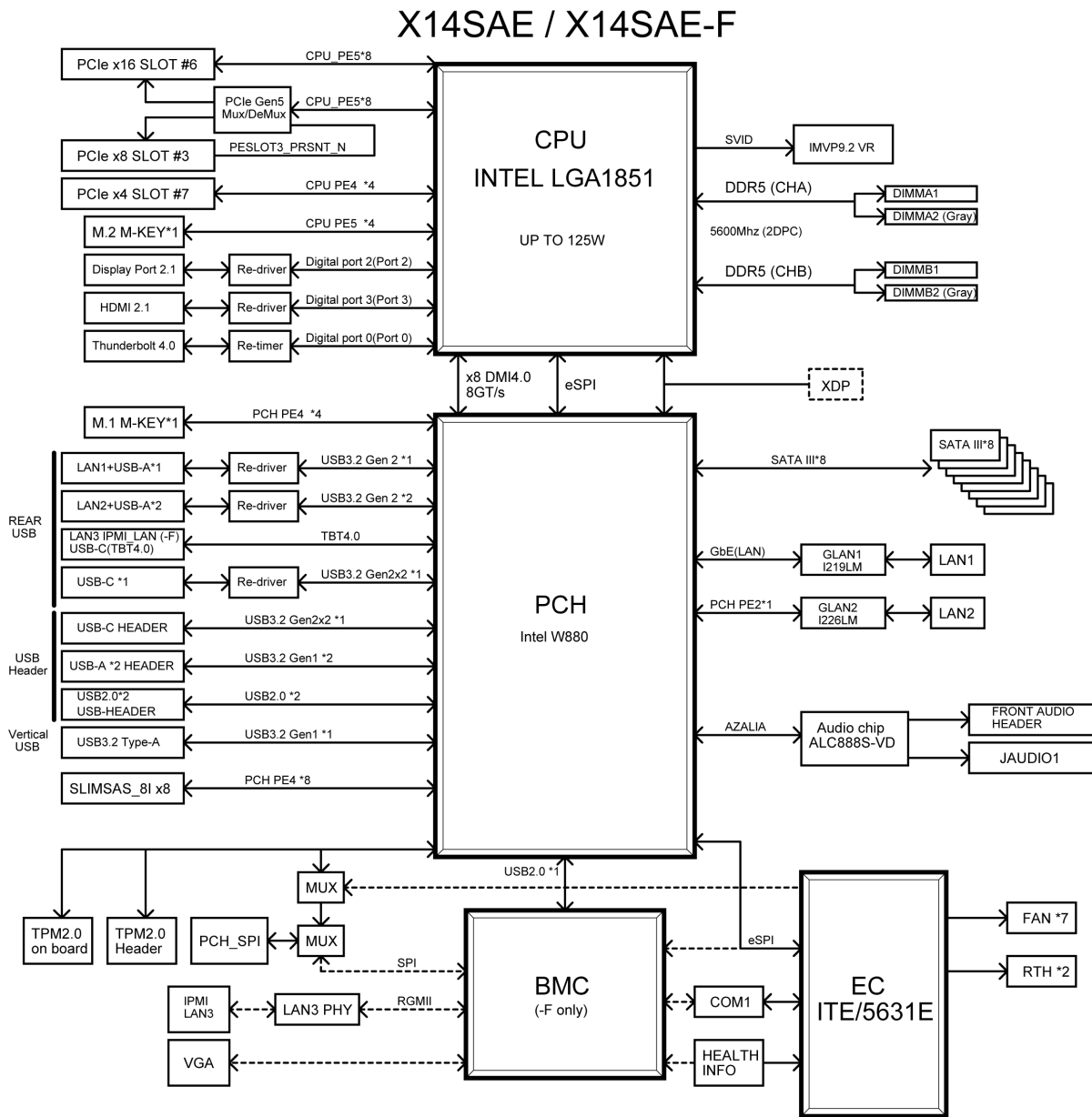

Figure 1-5. Motherboard Block Diagram

1.4 Motherboard Quick Reference

For details on the X14SAE motherboard layout and other quick reference information, refer to the content below.

Motherboard Layout

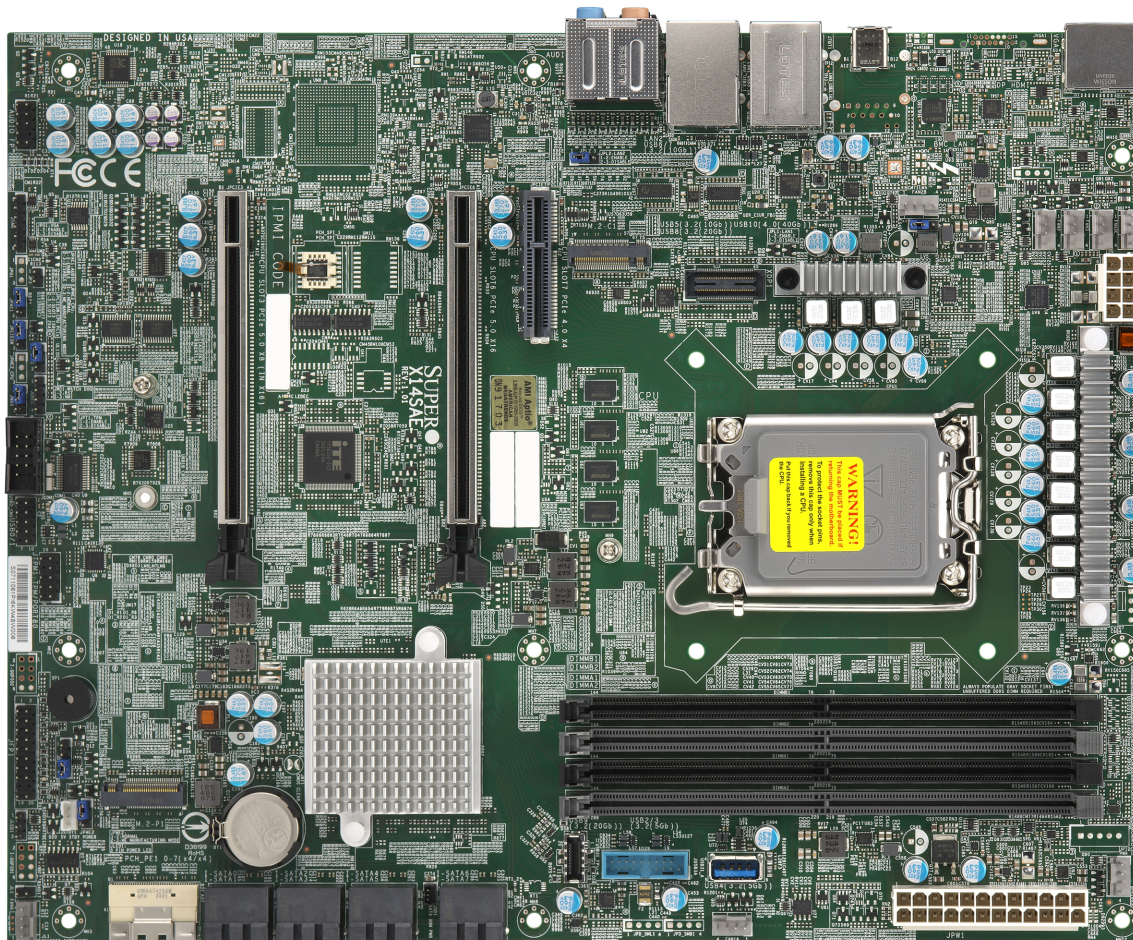

Figure 1-6. X14SAE Motherboard Image

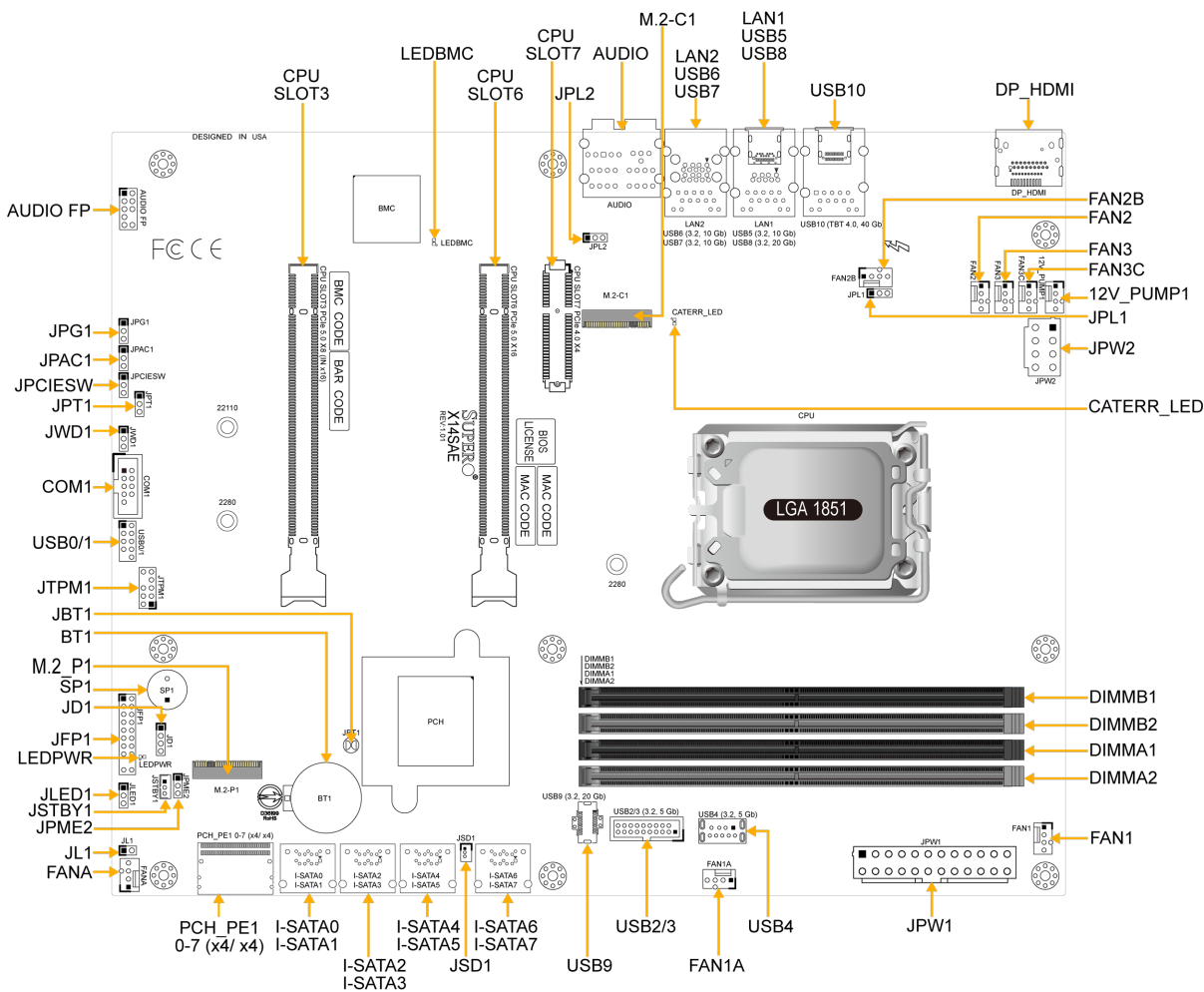

Figure 1-7. X14SAE Motherboard Layout

Notes:

- See "Maintenance and Component Installation" on page 28 for detailed information on jumpers, connectors, and LED indicators.
- "■" indicates the location of pin 1.
- Components not documented are for internal testing-purposes only.
- Use only the correct type of onboard CMOS battery as specified by the manufacturer. Do not install the onboard battery upside down to avoid possible explosion.

Quick Reference Table

Jumper	Description	Default
JBT1	Clear CMOS (Onboard)	Short Pads to Clear CMOS
JD1	External Speaker/Buzzer	Pins 1–4: External Speaker Pins 3–4: Buzzer (Default)
JPAC1	HD Audio Enable/Disable	Pins 1–2 (Enabled)
JPCIESW	CPU PCIe SLOT3 1x8/2x4	Pins 1–2: Slot3 1x8 (Default) Pins 2–3: Slot3 2x4
JPL1, JPL2	LAN1/LAN2 Enable/Disable	Pins 1–2 (Enabled)
JPME2	ME Manufacturing Mode	Pins 1–2 (Normal)
JPT1	Onboard TPM 2.0 Enable/Disable	Pins 1–2 (Enabled)
JWD1	Watchdog Function Enable	Pins 1–2 (Reset)

LED	Description	Status
CATERR_LED	Catastrophic Error LED	Solid Orange: System CATERR
LEDBMC	Standby Power LED	Solid Green: Standby Power On
LEDPWR	Onboard Power LED	Solid Green: Power On

Connector	Description
12V_PUMP1	4-pin +12 V Power Connector (for CPU liquid cooling pump)
AUDIO	Rear High Definition Audio Ports
AUDIO FP	Front Audio Header * The default setting is for a headphone/microphone combo jack. If not using a chassis with the headphone/microphone combo jack, configure Frontside Audio Mode in the BIOS Setup utility.
BT1	Onboard Battery
COM1	COM Header
DP_HDMI	DP: Rear DisplayPort 2.1. HDMI: High Definition Multimedia Interface 2.1

Connector	Description
FAN1, FAN1A, FAN2B, FANA	System Fan Headers
FAN2, FAN3, FAN3C	CPU Fan Headers
I-SATA0–I- SATA7	SATA 3.0 Ports (from Intel PCH, 6 Gb/sec, with support of RAID 0, 1, 5, and 10)
JFP1	Front Control Panel Header
JL1	Chassis Intrusion Header
JLED1	3-pin Power LED Indicator Header
JPW1	24-pin ATX Main Power Connector (Required)
JPW2	8-pin +12 V CPU Power Connector (Required)
JSD1	SATA Disk-On-Module (DOM) Power Connector
JSTBY1	Standby Power Header (5 V)
JTPM1	Trusted Platform Module (TPM)/Port 80 Header (TPM 2.0 only)
LAN1, LAN2	LAN1: RJ45 1 GbE LAN Port LAN2: RJ45 2.5 GbE LAN Port
M.2-C1	PCIe 5.0 x4 M.2 M-key Slot (from CPU, with support of 2280 form factor) * M.2-C1 and M.2-P1 can be mixed to support RAID 0 and 1.
M.2-P1	PCIe 4.0 x4 M.2 M-key Slot (from PCH, with support of 2280 and 22110 form factors) * M.2-P1 and M.2-C1 can be mixed to support RAID 0 and 1.
PCH_PE1 0-7 (x4/ x4)	PCIe 4.0 x8 SlimSAS 8i Side-facing Connector supporting two U.2 connections (from PCH)
SLOT3	PCIe 5.0 x8 (IN x16) Slot (from CPU, with support of 1x8 or 2x4 bifurcation) * SLOT3 will be enabled only when SLOT6 is populated. * SLOT3 supports single-width and double-width graphics cards.
SLOT6	PCIe 5.0 x16 Slot (from CPU, with support of 1x8 or 1x16 bifurcation) * SLOT6 will function at PCIe 1x8 when SLOT3 is populated or when SLOT3 is configured to 2x4 bifurcation mode. * SLOT6 supports storage and graphics card only.
SLOT7	PCIe 4.0 x4 Slot (from CPU)

Connector	Description
SP1	Internal Speaker/Buzzer
USB0/1	Front Accessible USB 2.0 Header
USB2/3	Front Accessible USB 3.2 Gen 1x1 Header (5 Gb)
USB4	Front Accessible USB 3.2 Gen 1x1 Header (5 Gb, Vertical)
USB5–USB7	Rear USB 3.2 Gen 2x1 Ports (10 Gb, Type-A)
USB8	Rear USB 3.2 Gen 2x2 Port (20 Gb, Type-C)
USB9	Front Accessible USB 3.2 Gen 2x2 Header (20 Gb, Type-C)
USB10	Rear Thunderbolt™ 4 (TBT 4) Port (40 Gb, Type-C)

Chapter 2:

Workstation Installation

This chapter provides advice and instructions for workstation installation. If your workstation is not already fully integrated with processors, system memory, etc., refer to "[Maintenance and Component Installation](#)" on page 28 for details on installing those specific components.

Important: Electrostatic Discharge (ESD) can damage electronic components. To prevent such damage to printed circuit boards (PCBs), it is important to use a grounded wrist strap, handle all PCBs by their edges, and keep PCBs in anti-static bags when not in use.

2.1 Unpacking the System	26
2.2 Preparing for Setup	27
Choosing a Setup Location	27
System Precautions	27

2.1 Unpacking the System

Inspect the box the workstation was shipped in and note if it was damaged in any way. If any equipment appears damaged, file a damage claim with the carrier who delivered it.

Decide on a suitable location for the workstation. It should be situated in a clean, dust-free area that is well ventilated. Avoid areas where heat, electrical noise and electromagnetic fields are generated. It will also require a grounded AC power outlet nearby. Be sure to read the precautions and considerations noted in "[Standardized Warning Statements for AC Systems](#)" on page 150.

2.2 Preparing for Setup

Read this section in its entirety before you begin the installation.

Choosing a Setup Location

- The workstation should be situated in a clean, dust-free area that is well ventilated. Avoid areas where heat, electrical noise and electromagnetic fields are generated.
- This product is not suitable for use with visual display workplace devices according to §2 of the German Ordinance for Work with Visual Display Units.

System Precautions

- Review the electrical and general safety precautions in "[Standardized Warning Statements for AC Systems](#)" on page 150.
- Use a regulating uninterruptible power supply (UPS) to protect the server from power surges and voltage spikes and to keep your system operating in case of a power failure.
- Allow any drives and power supply modules to cool before touching them.
- When not servicing, always keep all chassis panels on the servers closed to maintain proper cooling.

Chapter 3:

Maintenance and Component Installation

This chapter provides instructions on installing and replacing main system components for the SYS-532AW-C workstation. To prevent compatibility issues, only use components that match the specifications and/or part numbers given.

Installation or replacement of most components require that power first be removed from the system. Follow the procedures given in each section.

3.1 Removing Power	30
3.2 Accessing the System	31
Removing the Side Cover	31
Removing the Front Bezel	32
3.3 Static-Sensitive Devices	33
Precautions	33
3.4 Processor and Heatsink Installation	34
Installing an LGA 1851 Processor	35
Installing a Processor Heatsink	38
Removing the Processor Heatsink	41
3.5 Memory	42
Memory Support	42
General Guidelines for Optimizing Memory Performance	43
DIMM Installation	44
DIMM Removal	46
M.2 Device Installation	47
PCI Expansion Card Installation	52
3.6 Motherboard Battery Removal and Installation	53
Battery Removal	53
Proper Battery Disposal	53
Battery Installation	53
3.7 Storage Drives	54
3.8 System Cooling	55
Fans	55

Dust Filters	57
3.9 Power Supply	58
Replacing the Power Supply	58

3.1 Removing Power

Use the following procedure to ensure that power has been removed from the SYS-532AW-C workstation. This step is necessary when removing or installing non-hot-swap components or when replacing a non-redundant power supply.

1. Use the operating system to power down the system.
2. After the system has completely shut-down, disconnect the AC power cord from the power strip or outlet.
3. Disconnect the power cord from the power supply module.

3.2 Accessing the System

The SYS-532AW-C has two removable side covers.

Removing the Side Cover

Begin by removing power from the system as described in ["Removing Power" on the previous page](#).

1. Remove the two thumb screws on the rear of the chassis.
2. Slide the cover toward the rear of the chassis.
3. Remove the cover from the chassis.

Important: Except for short periods of time, do not operate the workstation without the cover in place. The chassis cover must be in place to allow for proper airflow and to prevent overheating.

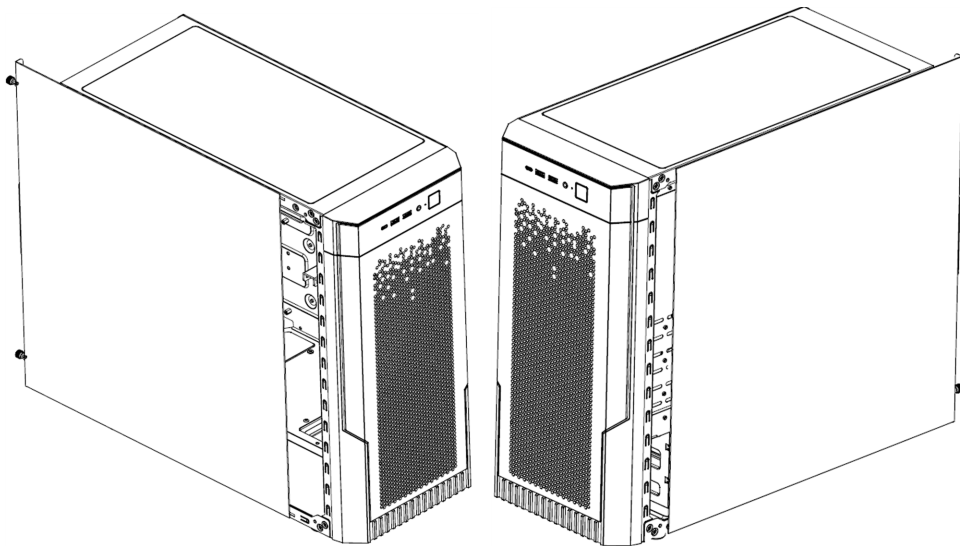

Figure 3-1. Removing the Side Cover

Removing the Front Bezel

Remove the front bezel by pulling off the bottom first. Generally, this is only necessary when replacing the front fans.

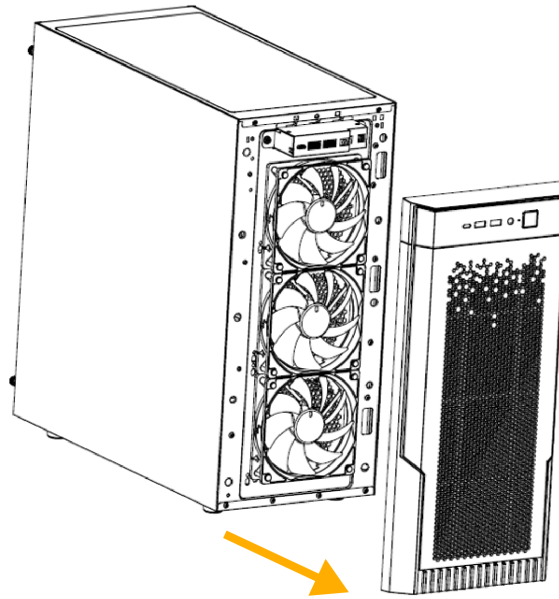

Figure 3-2. Removing the Front Bezel

3.3 Static-Sensitive Devices

Electrostatic Discharge (ESD) can damage electronic components. To avoid damaging your motherboard, it is important to handle it very carefully. The following measures are generally sufficient to protect your equipment from ESD.

Precautions

- Use a grounded wrist strap designed to prevent static discharge.
- Touch a grounded metal object before removing the board from the antistatic bag.
- Handle the motherboard by its edges only. Do not touch its components, peripheral chips, memory modules, or gold contacts.
- When handling chips or modules, avoid touching their pins.
- Put the motherboard and peripherals back into their antistatic bags when not in use.
- For grounding purposes, make sure that your computer chassis provides excellent conductivity between the power supply, the case, the mounting fasteners, and the motherboard.
- Use only the correct type of onboard CMOS battery. Do not install the onboard battery upside down to avoid possible explosion.

3.4 Processor and Heatsink Installation

This section provides procedures to install the processor(s) and heatsink(s).

Notes:

- Take industry standard precautions to avoid ESD damage. For details, see "[Static-Sensitive Devices](#)" on the previous page.
- Before starting, make sure that the plastic socket cap is in place and none of the socket pins are bent. If any damage is noted, contact your retailer.
- Do not connect the system power cord before the processor and heatsink installation is complete.
- When handling the processor, avoid touching or placing direct pressure on the LGA lands (gold contacts). Improper installation or socket misalignment can cause serious damage to the processor or processor socket.
- When buying a processor separately, use only a Supermicro certified heatsink.
- Refer to the Supermicro website for the most recent processor support.
- When installing the heatsink, ensure a torque driver set to the correct force is used for each screw.
- Thermal grease is pre-applied on a new heatsink. No additional thermal grease is needed.

Installing an LGA 1851 Processor

Important: You can only install the processor in one direction. Make sure it is properly inserted into the socket before closing the load plate. If it doesn't close properly, do not force it as it may damage your processor. Instead, open the load plate again and double-check that the processor is properly aligned.

1. Remove the plastic protective cover from the load plate.

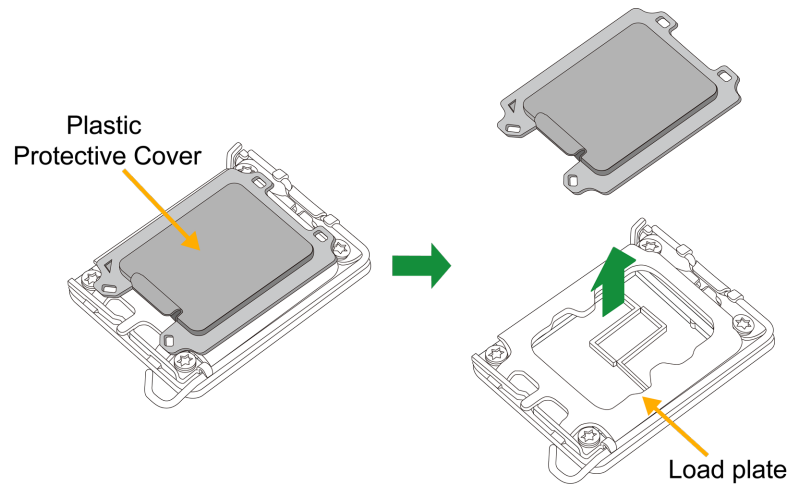

Figure 3-3. Remove the Protective Cover

2. Gently push the load lever down and away from the lever lock. Then lift it up completely.

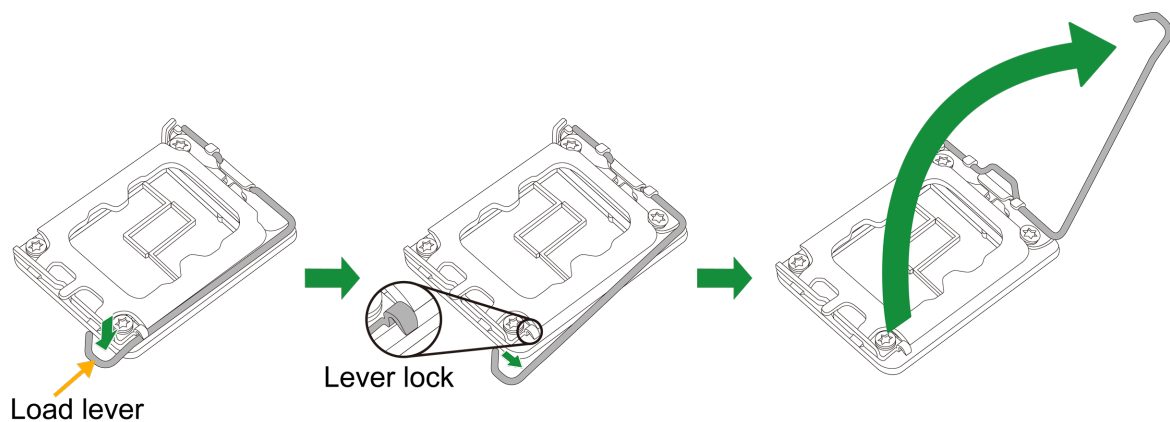

Figure 3-4. Release and Lift Up the Lever

3. Lift the load plate to open it completely.

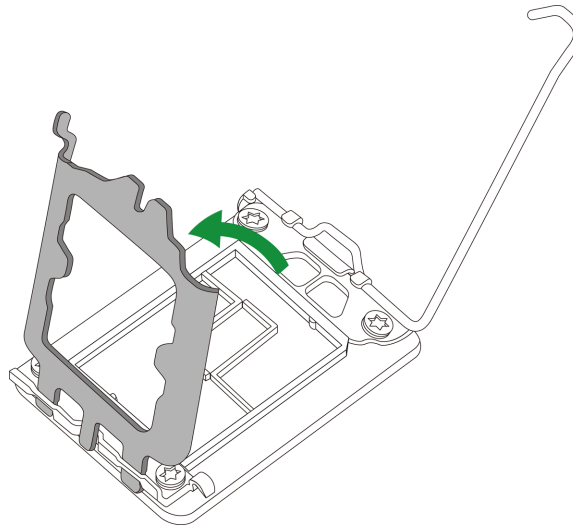

Figure 3-5. Open the load plate

4. Carefully hold the processor by its edges. Align the small triangle marker and notches on the processor with the corresponding triangle marker and notches on the processor load bracket. Once aligned, carefully lower the processor straight down into the socket. (Do not drop the processor on the socket, or move it horizontally or vertically.)

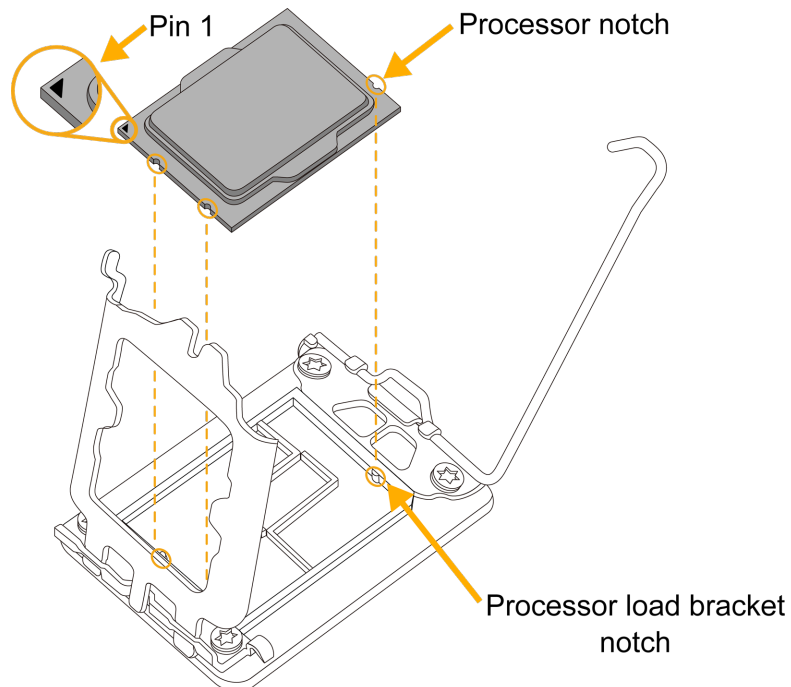

Figure 3-6. Align the Notches and Install the Processor

5. Do not rub the processor against the surface or against any pins of the socket to avoid damaging the processor or the socket.

6. With the processor inside the socket, inspect all the corners to make sure it is properly installed.
7. Close the load plate with the processor inside the socket. Gently push the load lever down until it locks under the lever lock.

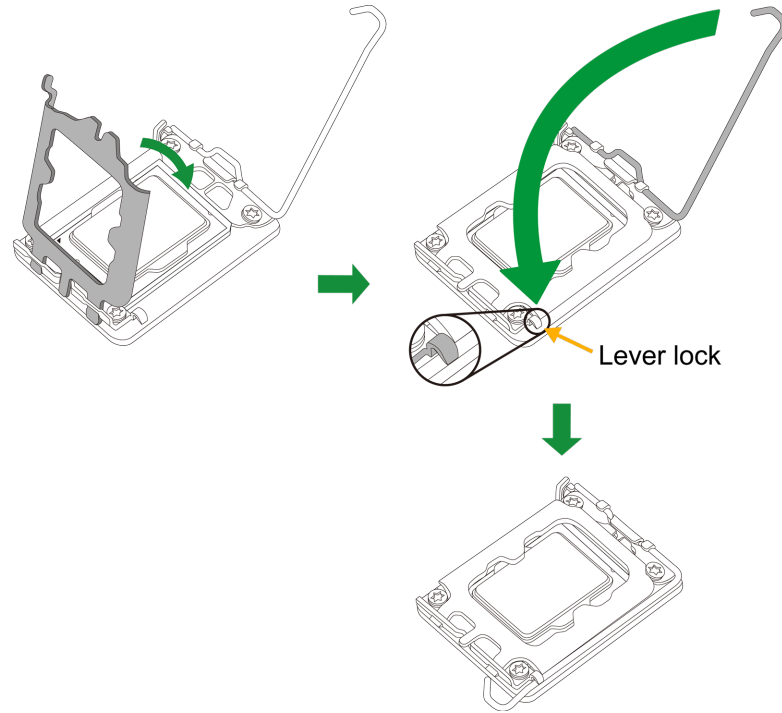

Figure 3-7. Close the Load Plate and Push the Lever Down

Installing a Processor Heatsink

Notes:

- The installation described in this section is for reference only. The actual installation steps may vary depending on the CPU heatsink model. Refer to the heatsink instructions for more details.
- Images displayed are for illustration purposes only. Your components might look different from those shown in this manual.

1. Loosen four screws to release the backplate. Note that one screw is not shown in the illustration below.

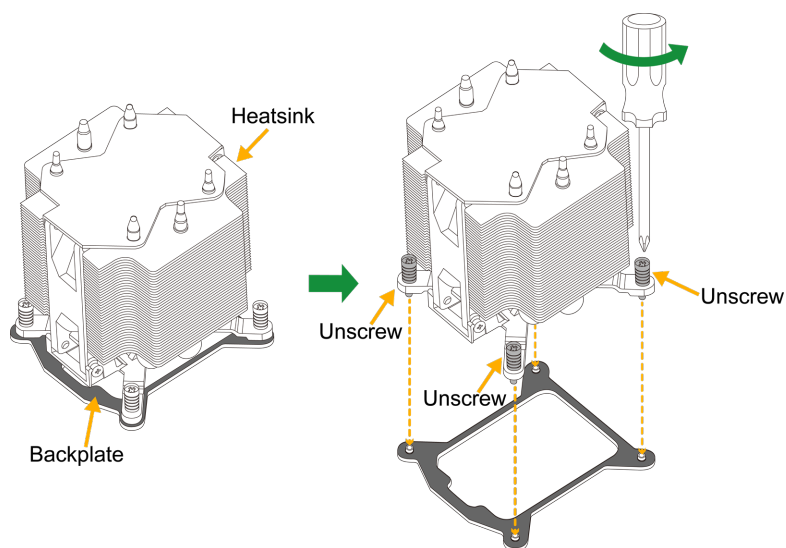

Figure 3-8. Release the Backplate from the Heatsink

2. If there is a thin layer of protective film on the backplate, remove it.

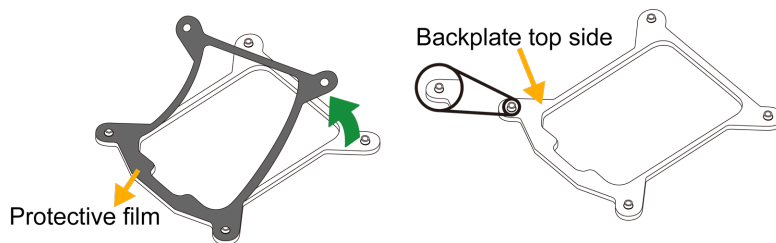

Figure 3-9. Remove the Protective Film

3. Attach the backplate into the mounting holes around the processor socket on the bottom side of the motherboard.

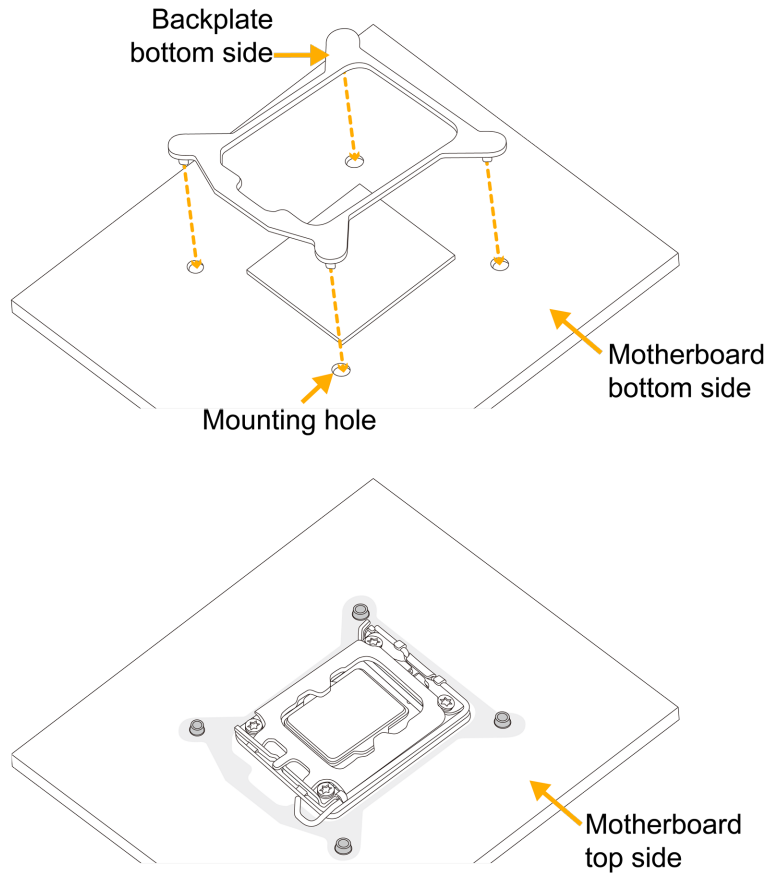

Figure 3-10. Attach the Backplate to the Bottom Side of the Motherboard

4. Apply the proper amount of thermal grease on the processor.

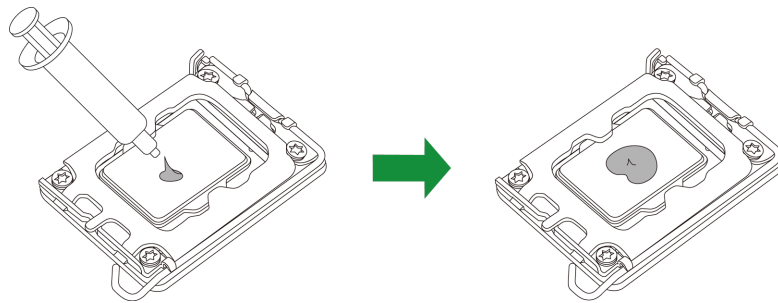

Figure 3-11. Apply Thermal Grease

5. Place the heatsink on top of the processor so that the four mounting holes on the heatsink are aligned with those on the retention mechanism.

6. Tighten the screws.

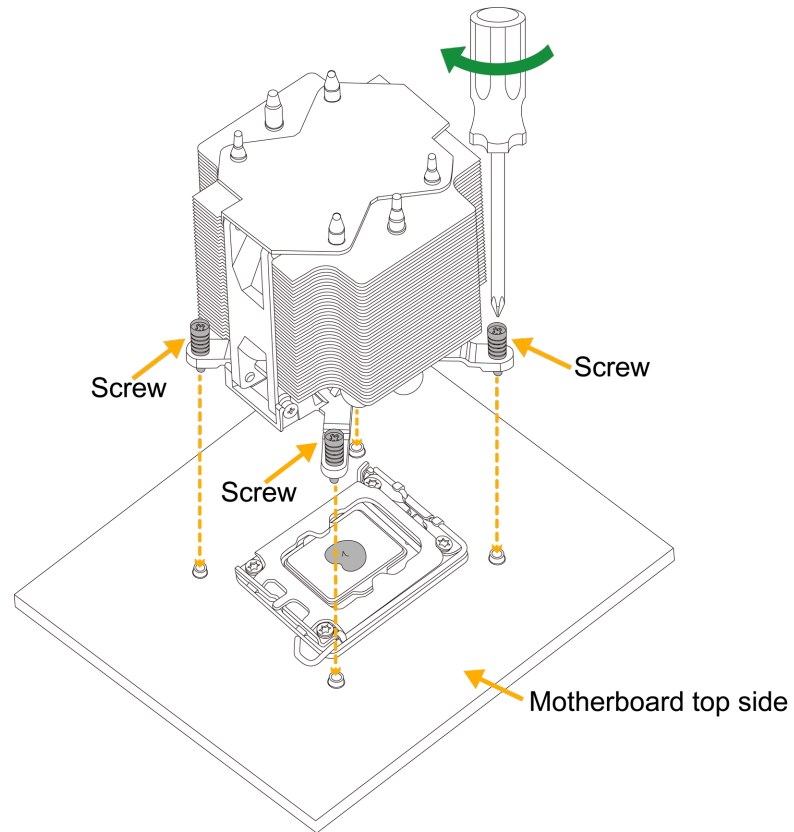

Figure 3-12. Tighten the Heatsink Screws

Removing the Processor Heatsink

Important: We do not recommend that the processor or heatsink be removed. However, if you do need to remove the heatsink, follow the instructions below to remove the heatsink and prevent damage done to the processor or other components.

1. Unplug the power cord from the power supply and the power connector from the cooler and fan header.
2. Loosen the screws as shown below.
3. Gently wiggle the heatsink to loosen it. Do not use excessive force when wiggling the heatsink.

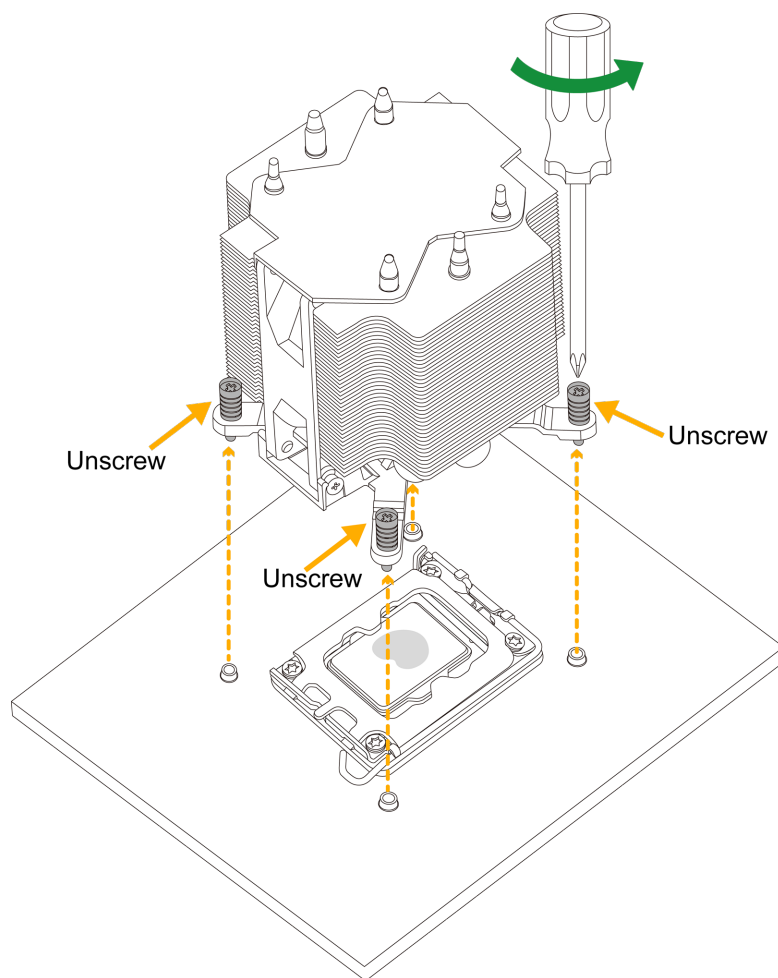

Figure 3-13. Loosen the Heatsink Screws

4. Once the heatsink is loosened, remove it from the motherboard.

3.5 Memory

Important: Exercise extreme care when installing or removing memory modules to prevent any damage.

Note: Check the Supermicro website for recommended memory modules.

Memory Support

The X14SAE motherboard supports up to 192 GB of Unbuffered (UDIMM) ECC/Non-ECC DDR5 memory with speeds of up to 5600 MT/s (1DPC), 4800 MT/s (2DPC, 1R DIMM), and 4400 MT/s (2DPC, 2R DIMM) in 4 288-pin memory slots.

Memory Population Table

Recommended Population (Balanced)				
DIMMA1	DIMMB1	DIMMA2	DIMMB2	Total System Memory
		8 GB DIMM	8 GB DIMM	16 GB
8 GB DIMM	8 GB DIMM	8 GB DIMM	8 GB DIMM	32 GB DIMM
		16 GB DIMM	16 GB DIMM	32 GB DIMM
		24 GB DIMM	24 GB DIMM	48 GB DIMM
16 GB DIMM	16 GB DIMM	16 GB DIMM	16 GB DIMM	64 GB DIMM
		32 GB DIMM	32 GB DIMM	64 GB DIMM
24 GB DIMM	24 GB DIMM	24 GB DIMM	24 GB DIMM	96 GB DIMM
		48 GB DIMM	48 GB DIMM	96 GB DIMM
32 GB DIMM	32 GB DIMM	32 GB DIMM	32 GB DIMM	128 GB DIMM
48 GB DIMM	48 GB DIMM	48 GB DIMM	48 GB DIMM	192 GB DIMM

Memory Support Table

Memory Support			
Frequency	4400 MT/s (2DPC)	4800 MT/s (2DPC)	5600 MT/s (1DPC)
DIMMA1	2R DIMM	1R DIMM	N/A
DIMMA2	2R DIMM	1R DIMM	1R or 2R DIMM
DIMMB1	2R DIMM	1R DIMM	N/A
DIMMB2	2R DIMM	1R DIMM	1R or 2R DIMM

General Guidelines for Optimizing Memory Performance

- It is recommended to use DDR5 memory of the same type, size, and speed.
- Mixed DIMM speeds can be installed. However, all DIMMs will run at the speed of the slowest DIMM.
- The motherboard will support an odd number amount of memory modules. However, to achieve the best memory performance, a balanced memory population is recommended.
- When installing memory modules, the DIMM slots should be populated in the following order: DIMMB2, DIMMA2, then DIMMB1, DIMMA1.
- When installing only two memory modules, please use DIMMB2 and DIMMA2.

DIMM Installation

Important: Do not use excessive force when pressing the release tabs on the ends of the DIMM socket to avoid causing any damage to the memory module or the DIMM socket. Handle memory modules with care. Carefully follow all the instructions given in "[Static-Sensitive Devices](#)" on [page 33](#) to avoid ESD-related damages done to your memory modules or components.

1. Insert the desired number of DIMMs into the memory slots based on the recommended DIMM population table earlier in this section.
2. Push the release tab outwards to unlock the slot.

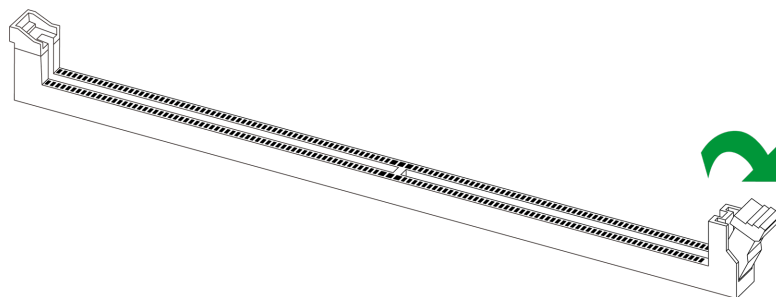

Figure 3-14. Unlock the DIMM Slot

3. Align the key of the DIMM with the receptive point on the memory slot.

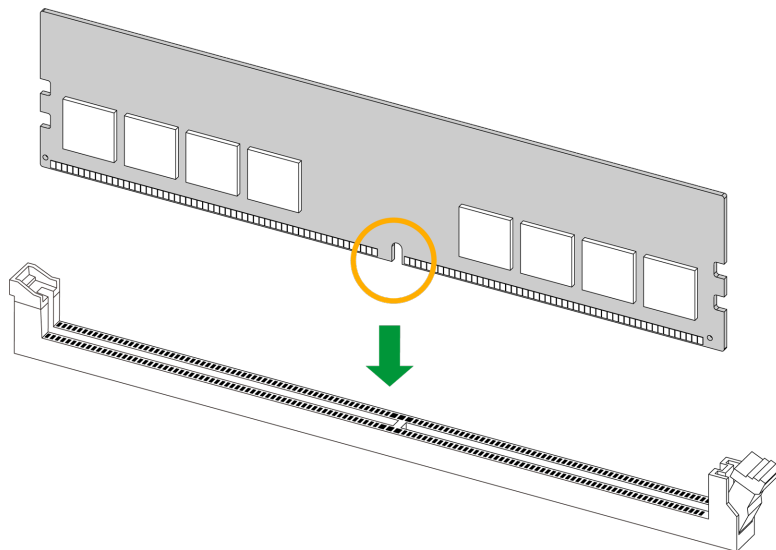

Figure 3-15. Align the DIMM Slot with the Receptive Point

4. Align the notches on both ends of the module against the receptive points on the ends of the slot.

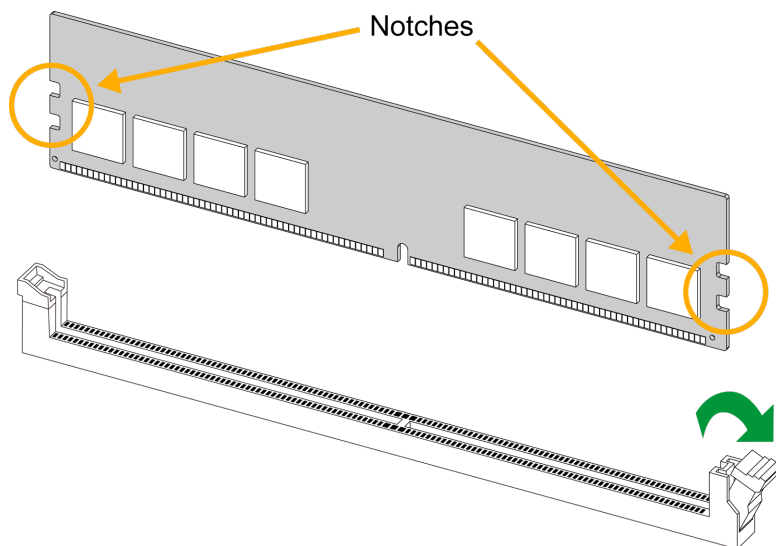

Figure 3-16. Align the Notches

5. Press both ends of the module straight down into the slot until the module snaps into place.
6. Press the release tab to the lock position to secure the DIMM into the slot.

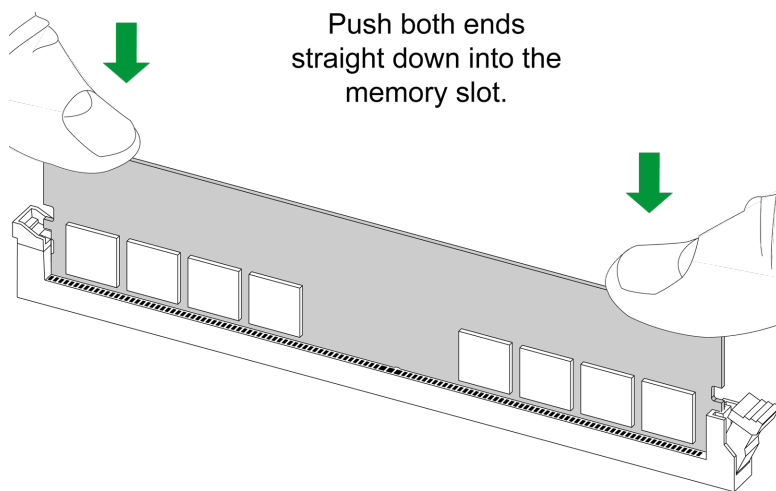

Figure 3-17. Press Both Ends

For a detailed diagram of the X14SAE motherboard, see the layout under ["Motherboard Quick Reference"](#) on page 20.

DIMM Removal

Important: Do not use excessive force when pressing the release tabs on the ends of the DIMM socket to avoid causing any damage to the memory module or the DIMM socket. Handle memory modules with care. Carefully follow all the instructions given in ["Static-Sensitive Devices"](#) on [page 33](#) to avoid ESD-related damages done to your memory modules or components.

Press the release tab of the DIMM socket to unlock it. Once the DIMM is loosened, remove it from the memory slot.

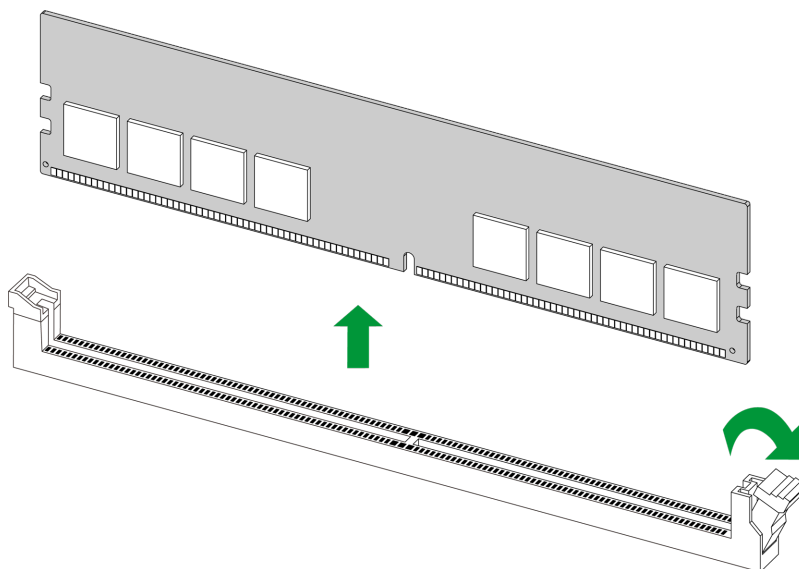

Figure 3-18. Unlock the DIMM Slot

For a detailed diagram of the X14SAE motherboard, see the layout under ["Motherboard Quick Reference"](#) on [page 20](#).

M.2 Device Installation

This motherboard has one PCIe 5.0 M.2 M-key slot (M.2-C1) that supports the M.2 2280 modules and one PCIe 4.0 M.2 M-key slot (M.2-P1) that supports the 2280/22110 modules. Two standoffs are pre-installed in the position of 2280 mounting hole (M.2-C1) and 22110 mounting hole (M.2-P1). Follow the steps below to install the M.2 device.

Notes:

- The installation described in this section is for reference only. The actual installation steps may vary depending on the supported M.2 form factors and the standoff pre-installed location.
- Images displayed are for illustration purposes only. Your components might look different from those shown in this manual.

Installing a Standard M.2 Device

1. Locate the screw on the pre-installed standoff. Remove the screw and set it aside.

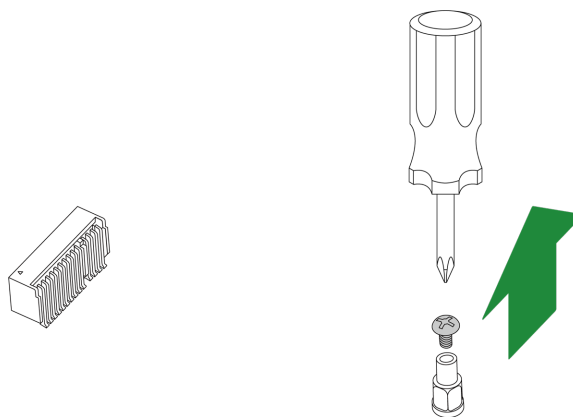

Figure 3-19. Remove the Screw on the Pre-installed Standoff

2. If the soon-to-be used mounting hole doesn't have a standoff, move the pre-installed one to that mounting hole.

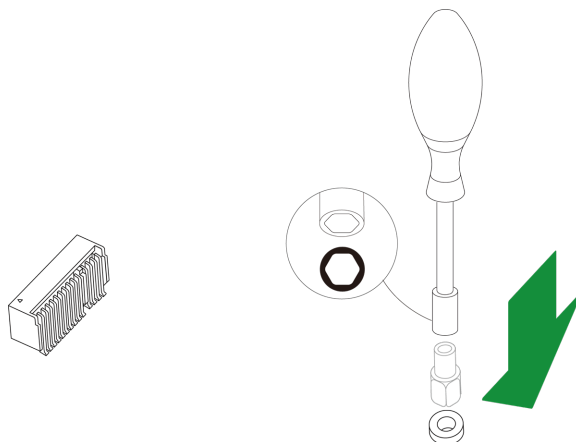

Figure 3-20. Change the Standoff Position as Needed

3. Carefully insert the M.2 device into the M.2 slot at a 30-degree angle and lower the semi-circle notched end onto the standoff.

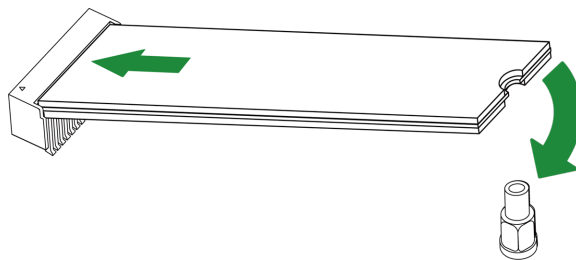

Figure 3-21. Insert the M.2 Device and Press it Down

4. Tighten the standoff screw to secure the M.2 device into place. Do not overtighten so as to avoid damaging the M.2 device.

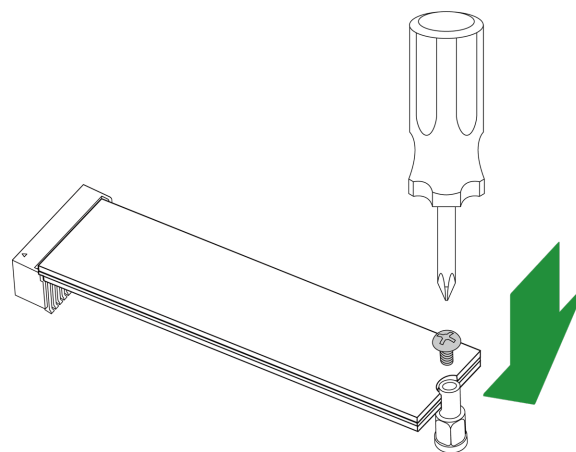

Figure 3-22. Secure the M.2 Device

Installing an M.2 Device with Heatsink (Optional)

It is strongly recommended that you install an M.2 heatsink provided by the M.2 device supplier. If you are using a Supermicro M.2 heatsink, follow the steps below:

Note: Images displayed are for illustration only. Your M.2 heatsink may not look exactly the same as the graphics shown in the manual.

1. Remove the thermal pad protective films from the cover and the tray of the M.2 heatsink.

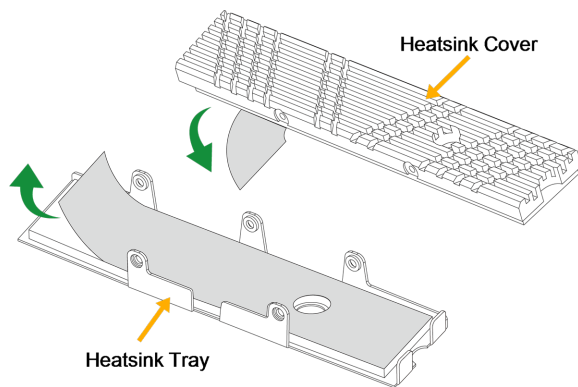

Figure 3-23. Remove the Protective Films from the Heatsink

2. Place the M.2 device into the tray, then put the heatsink cover in place. Be careful to align the tray holes with the cover holes.

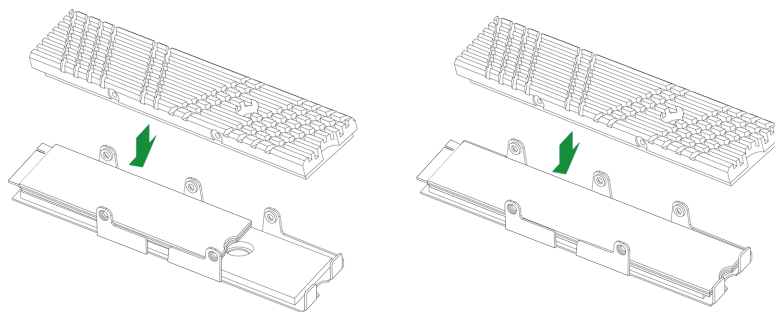

Figure 3-24. Create the M.2 Heatsink Assembly

3. Tighten the screws to secure the M.2 heatsink assembly.

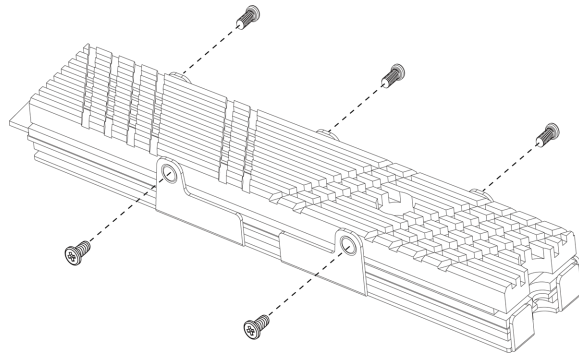

Figure 3-25. Secure the M.2 Heatsink Assembly

4. Locate the pre-installed standoff and screw. Remove the screw and set it aside.

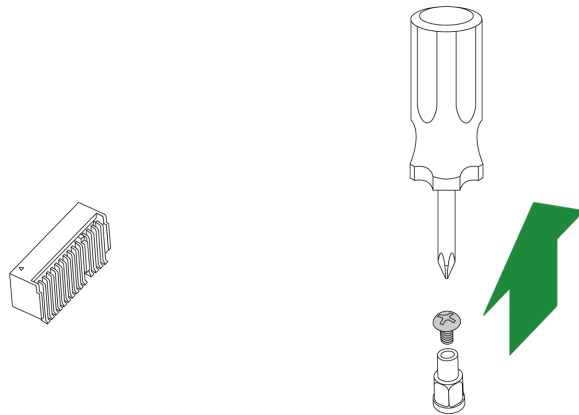

Figure 3-26. Remove the Screw on the Pre-installed Standoff

5. If the soon-to-be used mounting hole doesn't have a standoff, move the pre-installed one to that mounting hole.

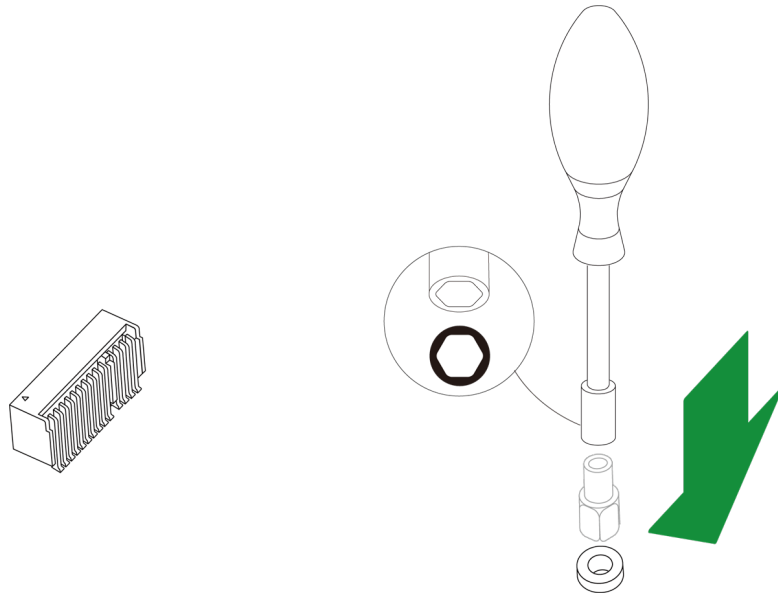

Figure 3-27. Change the Standoff Position as Needed

6. Carefully insert the M.2 assembly into the M.2 slot at a 30-degree angle and lower the assembly onto the standoff.

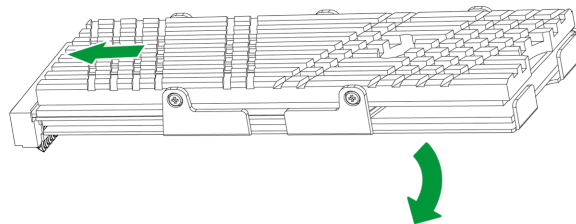

Figure 3-28. Insert the M.2 Heatsink Assembly and Press it Down

7. Tighten the standoff screw to secure the M.2 heatsink assembly into place. Do not overtighten so as to avoid damaging the M.2 assembly.

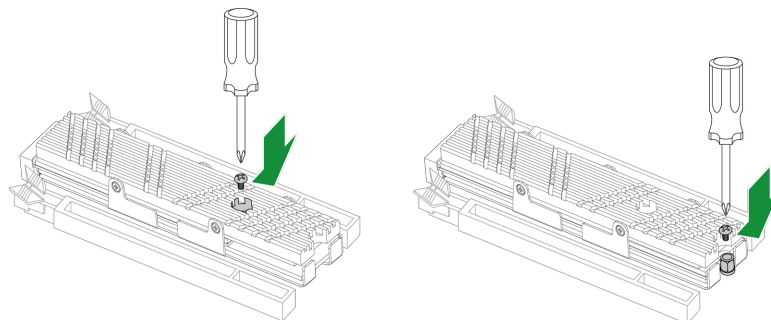

Figure 3-29. Secure the M.2 Heatsink Assembly

PCI Expansion Card Installation

After the motherboard has been installed, expansion cards may be installed.

Installing an Expansion Card

1. Begin by removing power from the system (see ["Removing Power" on page 30](#)) and removing the cover (see ["Accessing the System" on page 31](#)).
2. Remove the shield for the PCIe slot that you wish to populate. Verify that the card you are installing is supported by the slot.
3. Seat the card firmly into the slot by pushing down with your thumbs evenly on both sides of the card.
4. Use the thumb screw to secure the expansion card bracket to the rear of the chassis.
5. Repeat this process with each PCI expansion card you want to install into the chassis.

3.6 Motherboard Battery Removal and Installation

Battery Removal

To remove the onboard battery, follow the steps below:

1. Power off your system and unplug your power cable.
2. Locate the onboard battery as shown below.
3. Using a tool such as a pen or a small screwdriver, push the battery lock outwards to unlock it. Once unlocked, the battery will pop out from the holder.
4. Remove the battery.

Proper Battery Disposal

Important: Handle used batteries carefully. Do not damage the battery in any way; a damaged battery may release hazardous materials into the environment. Do not discard a used battery in the garbage or a public landfill. Comply with the regulations set up by your local hazardous waste management agency to dispose of your used battery properly.

Battery Installation

To install an onboard battery, follow steps 1 and 2 above and continue below:

Important: When replacing a battery, be sure to only replace it with the same type.

1. Identify the battery's polarity. The positive (+) side should be facing up.
2. Insert the battery into the battery holder and push it down until you hear a click to ensure that the battery is securely locked.

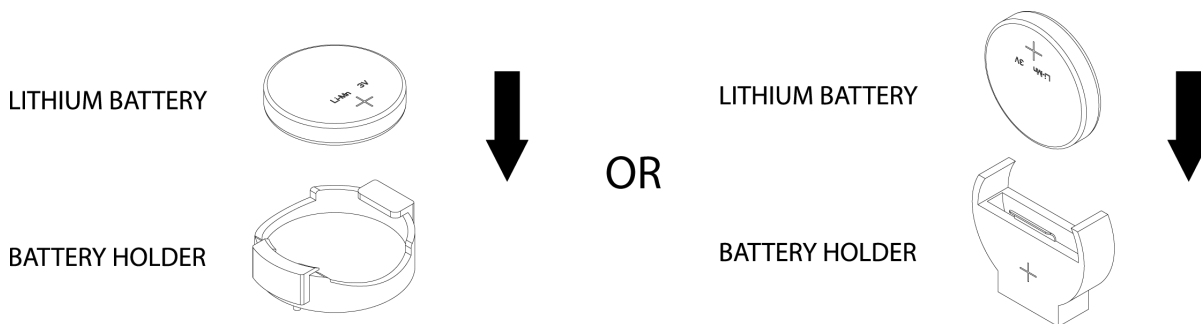

3.7 Storage Drives

The chassis can accommodate up to six 2.5" storage drives and two 3.5" storage drives. The installation location for the 2.5" storage drives has a thickness limitation of 9.5-mm.

The hard drives are mounted in drive carriers to simplify their installation and removal from the chassis.

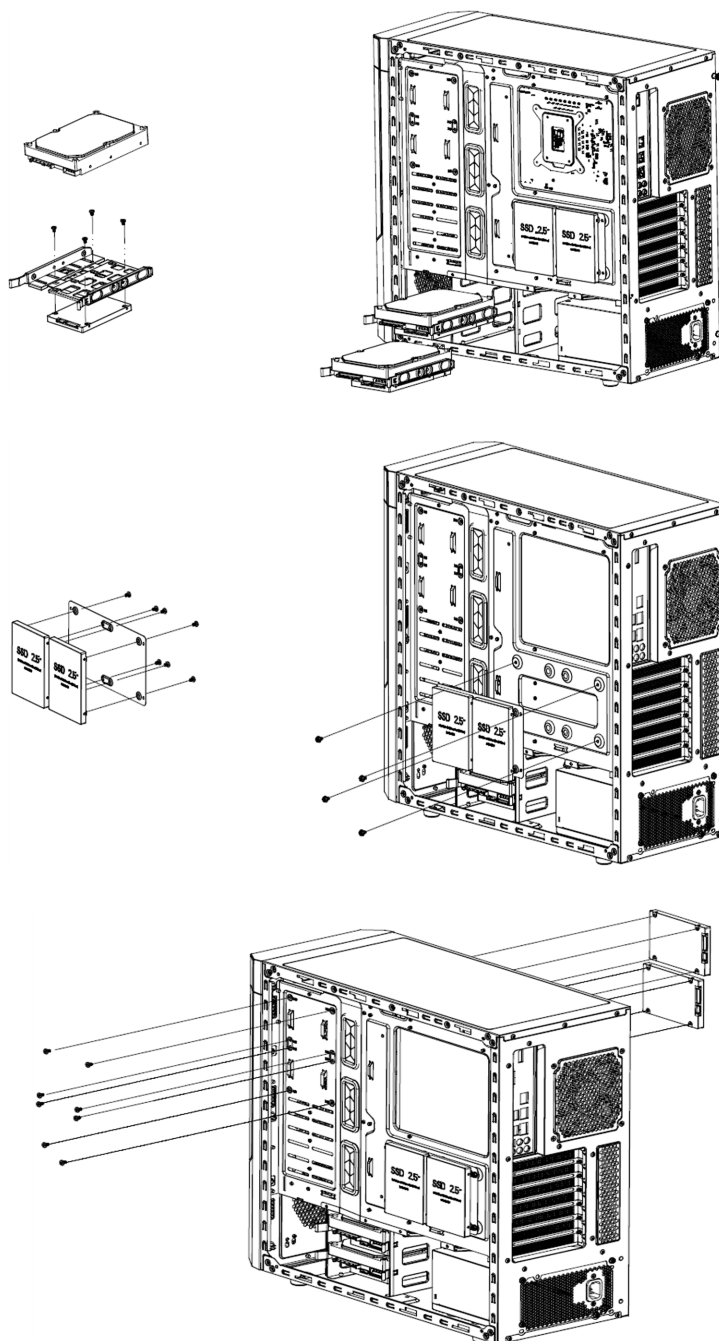

Figure 3-30. Installing Drives and Mounting Brackets into the Cage

3.8 System Cooling

Refer to the following sections for information about the cooling capabilities of the SYS-532AW-C workstation.

Fans

The chassis includes three 120-mm PWM fans in the front and one 120-mm PWM fan in the rear. Other fan mounts and configurations are possible.

- Two front fans can be upgraded to 140-mm.
- Three fans can be mounted on the chassis top, 120-mm or 140-mm.

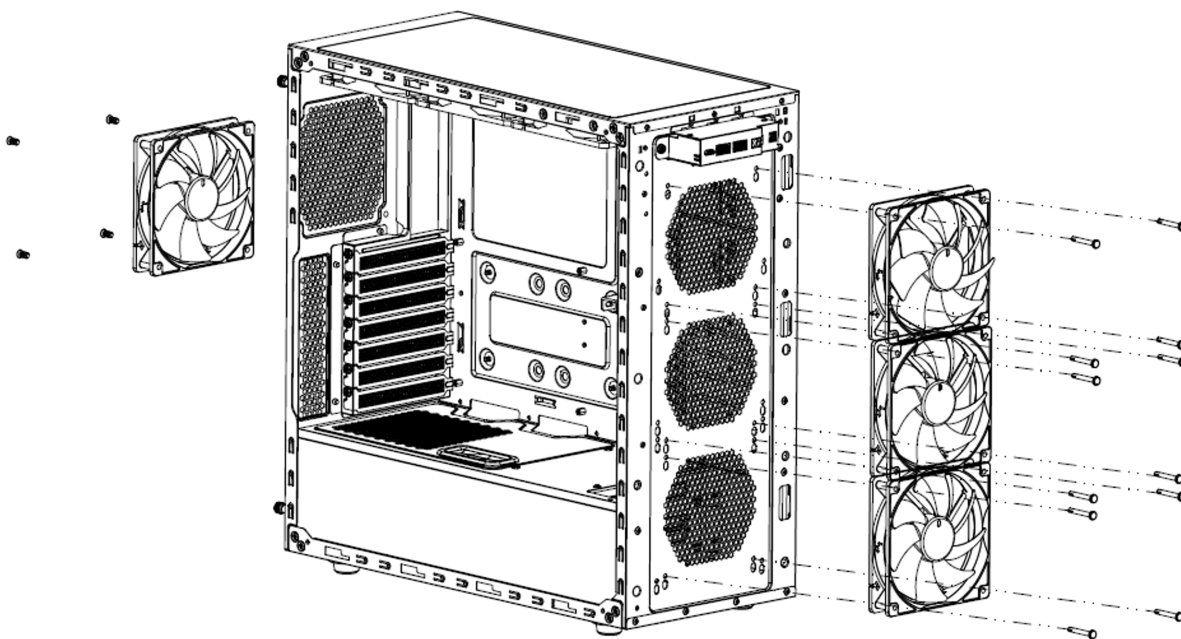

Figure 3-31. Standard Fan Placement

Important: Verify that cables do not obstruct the cooling airflow.

Replacing the Rear Fan

1. Begin by removing power from the system (see ["Removing Power" on page 30](#)) and removing the cover (see ["Accessing the System" on page 31](#)).
2. Loosen and remove the screws used to secure the rear fan to the chassis. Save the screws for later use.
3. Remove the fan cable from the motherboard.
4. Prepare the new fan for placement into the chassis.
5. Insert the screws through the mounting holes in the rear of the chassis and the fan.
6. Connect the fan cable to the motherboard.

Replacing the Front Fan

1. Begin by removing power from the system (see ["Removing Power" on page 30](#)) and removing the cover (see ["Accessing the System" on page 31](#)).
2. Remove the plastic push pins from the fan's mounting holes.
3. Raise the failed fan out of the chassis and prepare the new fan for placement.
4. Lower the new fan into the chassis, so the holes at the top of the front fan bracket align with the holes in the chassis.
5. Insert the four plastic push pins through the front fan bracket and into the mounting holes of the new front fan.
6. Pull the pins through the mounting holes of the system fan to secure the fan to the chassis.

Dust Filters

The chassis has one magnetic dust filter on the top and a dust filter that covers the front fans. Dust filters can be removed and cleaned to improve system air flow circulation.

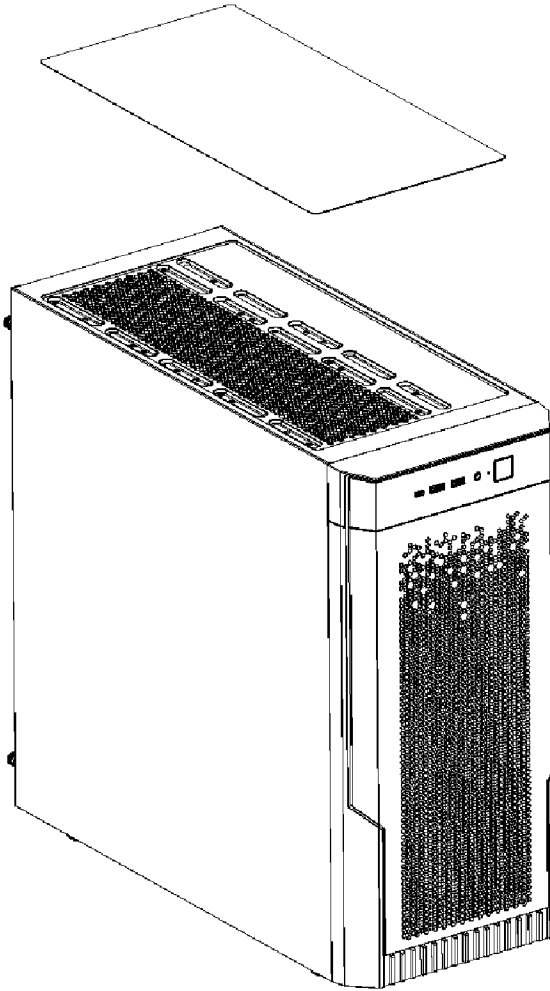

Figure 3-32. Top Dust Filter

3.9 Power Supply

The SYS-532AW-C supports the standard PS/2 form factor power supply up to 160-mm in length. The SYS-532AW-C includes one 1000 W Multi-Output 80Plus Gold power supply.

Replacing the Power Supply

1. Begin by removing power from the system (see ["Removing Power" on page 30](#)) and removing the left chassis cover (see ["Accessing the System" on page 31](#)).
2. Disconnect the cables from the motherboard to the power supply.
3. Remove the screws securing the power supply to the chassis, which are located on the rear of the chassis. Save the screws for later use.
4. Lift the power supply out of the chassis.
5. Replace the failed power supply with an identical power supply model.
6. Secure the new power supply using the screws previously saved.
7. Plug the AC power cord back into the module and power-up the system.

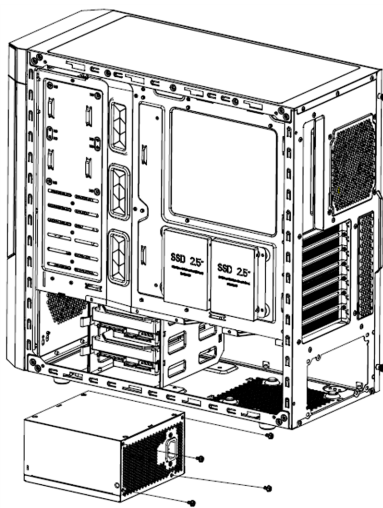

Figure 3-33. Power Supply

Chapter 4:

Motherboard Connections, Jumpers, and LEDs

This section describes the connections on the motherboard and provides pinout definitions. Note that depending on how the system is configured, not all connections are required. The LEDs on the motherboard are also described here. A motherboard layout indicating component locations may be found in the ["Introduction" on page 12](#). More detail can be found in the X14SAE motherboard manual.

Review the ["Standardized Warning Statements for AC Systems" on page 150](#) before installing or removing components.

4.1 Power Connections	61
ATX Power Supply Connection	61
4.2 Headers and Connections	63
COM Header	63
DOM Power Connector	63
Fan Headers	64
Front Panel Audio Header	64
Internal Speaker/Buzzer	65
M.2 M-Key PCIe 5.0/4.0 x4 Slots	65
Power LED Header	65
Pump Power Header	66
SATA 3.0 Ports	66
SlimSAS 8i Connector	66
Standby Power	67
TPM/Port 80 Header	67
USB Headers	68
4.3 Rear I/O Ports	70
DisplayPort	71
HDMI Port	71
USB Ports	71
High Definition Audio (HD Audio) Ports	71
4.4 Jumper Settings	73

CMOS Clear	73
CPU PCIe SLOT3 1x8/2x4	74
External Speaker / Buzzer	74
HD Audio Enable/Disable	74
LAN Enable/Disable	75
ME Manufacturing Mode	75
Onboard TPM Enable/Disable	75
Watchdog Timer	76
4.5 LED Indicators	77
CATERR LED	77
Onboard Power LED	77
Standby Power	78

4.1 Power Connections

For information about the power connections of the SYS-532AW-C workstation, refer to the following content.

Important: To provide adequate power supply to the motherboard, be sure to connect the 24-pin ATX PWR and the 8-pin PWR connections to the power supply. Failure to do so may void the manufacturer warranty on your power supply and motherboard.

ATX Power Supply Connection

The primary 24-pin power supply connection (JPW1 on the X14SAE motherboard) meets the ATX SSI EPS 12 V specification. JPW2 is an 8-pin +12 V DC power input for the processor that must be connected to the power supply.

Important: To provide adequate power supply to the motherboard, be sure to connect the 24-pin ATX PWR and the 8-pin PWR connections to the power supply. Failure to do so may void the manufacturer warranty on your power supply and motherboard.

For a detailed diagram of the X14SAE motherboard, see the layout under "[Motherboard Quick Reference](#)" on page 20.

8-pin CPU Power Pin Definitions: Eight Total	
Pin#	Definition
1-4	GND
5-8	+12 V (12 V Power)

ATX Power 24-pin Connection Pin Definitions: 24 Total			
Pin#	Definition	Pin#	Definition
13	+3.3 V	1	+3.3 V
14	No Connection	2	+3.3 V
15	GND	3	GND
16	PS_ON	4	+5 V
17	GND	5	GND
18	GND	6	+5 V
19	GND	7	GND
20	Res (No Connection)	8	PWR_OK
21	+5 V	9	+5 VSB
22	+5 V	10	+12 V
23	+5 V	11	+12 V
24	GND	12	+3.3 V

4.2 Headers and Connections

For information about the headers of the SYS-532AW-C workstation, refer to the following content.

COM Header

There is one COM header at COM1 on the X14SAE motherboard. Use a cable with the COM header to access the COM1 COM port. COM ports provide serial communication support.

For a detailed diagram of the X14SAE motherboard, see the layout under "[Motherboard Quick Reference](#)" on page 20.

COM Header			
Pin Definitions: Nine Total			
Pin#	Definition	Pin#	Definition
1	SP_DCD0	6	SP_DSR0
2	SP_RXD0	7	SP_RTS0
3	SP_TXD0	8	SP_CTS0
4	SP_DTR0	9	SP_RI0
5	GND		

DOM Power Connector

The Disk-On-Module (DOM) power connector, located at JSD1, provides 5V power to a solid state DOM storage device connected to one of the SATA ports.

For a detailed diagram of the X14SAE motherboard, see the layout under "[Motherboard Quick Reference](#)" on page 20.

DOM Power Connector	
Pin Definitions: Three Total	
Pin#	Definition
1	+5 V
2	GND
3	GND

Fan Headers

There are seven 4-pin fan headers (FAN1, FAN1A, FAN2B, FANA, FAN2, FAN3, and FAN3C) on the X14SAE motherboard. Although pins 1-3 of the system fan headers are backwards compatible with the traditional 3-pin fans, the 4-pin fans are recommended to take advantage of the fan speed control. This allows fan speeds to be automatically adjusted based on the motherboard temperature.

For a detailed diagram of the X14SAE motherboard, see the layout under "[Motherboard Quick Reference](#)" on page 20.

4-pin Fan Header	
Pin Definitions: Four Total	
Pin#	Definition
1	GND (Black)
2	+12 V (Red)
3	Tachometer
4	PWM Control

Front Panel Audio Header

A 10-pin audio header located at AUDIO_FP/AUDIO FP is supported on the X14SAE motherboard. This header allows you to connect the motherboard to the audio port on the front panel. If needed, connect an audio cable (not supplied) to the audio header to use this feature.

Note: The audio header's default setting is for a headphone/microphone combo jack. If you want to connect it to HD Audio or AC'97 audio port, configure the Frontside Audio Mode feature in the BIOS Setup utility.

For a detailed diagram of the X14SAE motherboard, see the layout under "[Motherboard Quick Reference](#)" on page 20.

Front Panel Audio Header			
Pin Definitions: 10 Total			
Pin#	Definition	Pin#	Definition
1	Microphone_Left	6	GND
2	Audio_GND	7	Jack_Detect
3	Microphone_Right	8	Key

Front Panel Audio Header			
Pin Definitions: 10 Total			
Pin#	Definition	Pin#	Definition
4	Audio_Detect	9	Line_2_Left
5	Line_2_Right	10	GND

Internal Speaker/Buzzer

The Internal Speaker/Buzzer (SP1) is used to provide audible indications for various beep codes.

For a detailed diagram of the X14SAE motherboard, see the layout under "[Motherboard Quick Reference](#)" on page 20.

Internal Speaker/Buzzer		
Pin Definitions: Two Total		
Pin#	Definition	
1	Pos (+)	Beep In
2	Neg (-)	Alarm Speaker

M.2 M-Key PCIe 5.0/4.0 x4 Slots

Two M.2 M-key slots are located at M.2-C1 and M.2-P1 on the X14SAE motherboard. Refer to the table below for more information.

Slots	Signals	Bus Interface	Form Factors	RAID Support
M.2-C1	From CPU	PCIe 5.0 x4	2280	RAID 0 and 1
M.2-P1	From PCH	PCIe 4.0 x4	2280 and 22110	RAID 0 and 1

Note: M.2-C1 and M.2-P1 slots can be mixed to support RAID 0 and 1.

For a detailed diagram of the X14SAE motherboard, see the layout under "[Motherboard Quick Reference](#)" on page 20.

Power LED Header

An onboard Power LED header is located at JLED1. This Power LED header is used to indicate the status of system power.

For a detailed diagram of the X14SAE motherboard, see the layout under "[Motherboard Quick Reference](#)" on page 20.

Power LED Header	
Pin Definitions: Three Total	
Pin#	Definition
1	POWER LED (+)
2	POWER LED (-)
3	POWER LED (-)

Pump Power Header

The X14SAE motherboard has one +12 V header for optional CPU liquid cooling systems. When using a liquid cooling system, attach the pump power cable to the 12V_PUMP1 header.

For a detailed diagram of the X14SAE motherboard, see the layout under "[Motherboard Quick Reference](#)" on page 20.

Pump Power Header	
Pin Definitions: Four Total	
Pin#	Definition
1	GND (Black)
2	2A/+12 V (Red)
3	N/A
4	N/A

SATA 3.0 Ports

Eight Serial ATA (SATA) 3.0 ports (I-SATA0–I-SATA7) are supported on the X14SAE motherboard. These I-SATA 3.0 ports are supported by the Intel PCH chip (supporting RAID 0, 1, 5, and 10).

For a detailed diagram of the X14SAE motherboard, see the layout under "[Motherboard Quick Reference](#)" on page 20.

SlimSAS 8i Connector

A PCIe 4.0 x8 SlimSAS 8i connector is located at PCH_PE1 0-7 (x4/ x4) on the X14SAE motherboard. The connector is supported by the PCH and it supports two PCIe 4.0 x4 U.2 connections.

Standby Power

The Standby Power header is located at JSTBY1 on the motherboard. You must have a card with a Standby Power connector and a cable to use this feature.

For a detailed diagram of the X14SAE motherboard, see the layout under "[Motherboard Quick Reference](#)" on page 20.

Standby Power	
Pin Definitions: Three Total	
Pin#	Definition
1	+5 V Standby
2	GND
3	GND

TPM/Port 80 Header

The JTPM1 header on the X14SAE motherboard is used to connect a Trusted Platform Module (TPM)/Port 80, which is available from Supermicro (optional). A TPM/Port 80 connector is a security device that supports encryption and authentication in hard drives. It allows the motherboard to deny access if the TPM associated with the hard drive is not installed in the system. Go to the following link for more information on the TPM: https://www.supermicro.com/manuals/other/AOM-TPM-9670V_9670H_X12_H12.pdf.

For a detailed diagram of the X14SAE motherboard, see the layout under "[Motherboard Quick Reference](#)" on page 20.

Trusted Platform Module Header			
Pin Definitions: 10 Total			
Pin#	Definition	Pin#	Definition
1	+3.3 V	2	SPI_CS#
3	RESET#	4	SPI_MISO
5	SPI_CLK	6	Ground
7	SPI_MOSI	8	No Connection
9	+3.3 V Stdby	10	SPI_IRQ#

USB Headers

There is one USB 2.0 header (USB0/1) and one USB 3.2 Gen 1x1 header (USB2/3) on the X14SAE motherboard, each supporting two USB connections. There is also one USB 3.2 Gen 1x1 header (USB4, vertical), and one USB 3.2 Gen 2x2 header (USB9) located on the motherboard. These headers provide front access using USB cables (not included).

(USB 2.0) Header			
Pin Definitions: 10 Total			
Pin#	Definition	Pin#	Definition
1	+5 V	2	+5 V
3	USB_N	4	USB_N
5	USB_P	6	USB_P
7	GND	8	GND
9	Key	10	No Connection

USB 3.2 Gen 2x2 Header			
Pin Definitions: 20 Total			
Pin#	Definitions	Pin#	Definitions
1	VBUS	11	VBUS
2	TX1+	12	TX2+
3	TX1-	13	TX2-
4	GND	14	GND
5	RX1+	15	RX2+
6	RX1-	16	RX2-
7	VBUS	17	GND
8	CC1	18	D-
9	No Connection	19	D+
10	No Connection	20	CC2

USB 3.2 Gen 1x1 Header			
Pin Definitions: 19 Total			
Pin#	Definitions	Pin#	Definitions
1	VBUS	11	IntA_P2_D+
2	IntA_P1_SSRX-	12	IntA_P2_D-
3	IntA_P1_SSRX+	13	GND
4	GND	14	IntA_P2_SSTX+
5	IntA_P1_SSTX-	15	IntA_P2_SSTX-
6	IntA_P1_SSTX+	16	GND
7	GND	17	IntA_P2_SSRX+
8	IntA_P1_D-	18	IntA_P2_SSRX-
9	IntA_P1_D+	19	VBUS
10	GND		

For a detailed diagram of the X14SAE motherboard, see the layout under "[Motherboard Quick Reference](#)" on page 20.

4.3 Rear I/O Ports

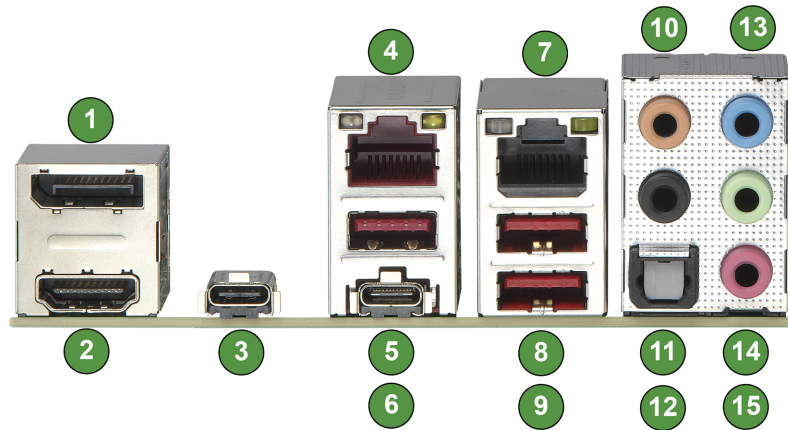

Figure 4-1. Rear I/O Ports

Rear I/O Ports	
No.	Descriptions
1	DisplayPort 2.1
2	HDMI 2.1 Port
3	TBT 4 (40 Gb, Type-C)
4	RJ45 1 GbE LAN Port
5	USB 3.2 Gen 2x1 Port (10 Gb, Type-A)
6	USB 3.2 Gen 2x2 Port (20 Gb, Type-C)
7	RJ45 2.5 GbE LAN Port
8	USB 3.2 Gen 2x1 Port (10 Gb, Type-A)
9	USB 3.2 Gen 2x1 Port (10 Gb, Type-A)
10	Center / LFE Out
11	Surround Out
12	S/PDIF Out
13	Line In
14	Line Out
15	Mic In

DisplayPort

DisplayPort 2.1, developed by the VESA consortium, delivers digital display at a fast refresh rate. It can connect to virtually any display device using a DisplayPort adapter for devices, such as VGA, DVI, and HDMI.

For a detailed diagram of the X14SAE motherboard, see the layout under "[Motherboard Quick Reference](#)" on page 20.

HDMI Port

One High-Definition Multimedia Interface (HDMI) 2.1 port is located on the rear I/O of the X14SAE motherboard. This port is used to display both high definition video and digital sound through an HDMI display, using a single HDMI cable (not included).

For a detailed diagram of the X14SAE motherboard, see the layout under "[Motherboard Quick Reference](#)" on page 20.

USB Ports

There are three USB 3.2 Gen 2x1 Type-A ports (USB5–USB7), and one USB 3.2 Gen 2x2 Type-C port (USB8) on the rear I/O of the X14SAE motherboard. In addition, a Thunderbolt 4 (TBT 4) Type-C port (USB10) is located on the rear I/O of the X14SAE motherboard. The Thunderbolt 4 port supports USB, DisplayPort, and PCI Express, enabling you to connect a variety of devices such as external monitors, storage drives, and docking stations.

There are also three front accessible USB headers on the X14SAE motherboard. Refer to the "[USB Headers](#)" on page 68 section for details.

For a detailed diagram of the X14SAE motherboard, see the layout under "[Motherboard Quick Reference](#)" on page 20.

High Definition Audio (HD Audio) Ports

This X14SAE features a 7.1+2 Channel High Definition Audio (HDA) codec that provides 10 DAC channels. The HD Audio connections simultaneously supports multiple-streaming 7.1 sound playback with 2 channels of independent stereo output through the front panel stereo out for front, rear, center and subwoofer speakers. Use the Advanced software included in the CD-ROM with your motherboard to enable this function.

For a detailed diagram of the X14SAE motherboard, see the layout under "[Motherboard Quick Reference](#)" on page 20.

Audio Configuration					
		2 Channel	4.1 Channel	5.1 Channel	7.1 Channel
1	Orange (Center / Subwoofer)			Center / Subwoofer	Center / Subwoofer
2	Black (Rear Speaker Out)		Rear Speaker Out	Rear Speaker Out	Rear Speaker Out
3	Light Blue (Line In / Side Speaker Out)	Line In			Side Speaker Out
4	Lime (Line Out / Front Speaker Out)	Line Out	Front Speaker Out	Front Speaker Out	Front Speaker Out
5	Pink (Mic In)	Mic In	Mic In	Mic In	Mic In

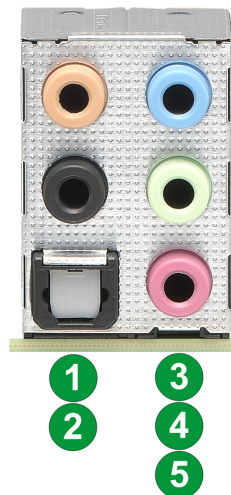
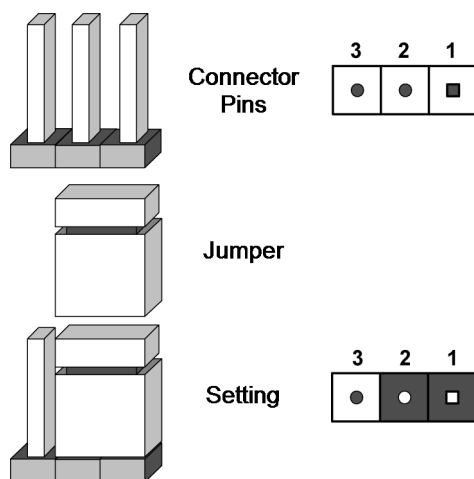

Figure 4-2. HD Audio Ports

4.4 Jumper Settings

To modify the operation of the motherboard, jumpers can be used to choose between optional settings. Jumpers create shorts between two pins to change the function of the connector. Pin 1 is identified with a square solder pad on the printed circuit board. See the diagram below for an example of jumping pins 1 and 2. Refer to the motherboard layout page for jumper locations.

Note: On two-pin jumpers, "Closed" means the jumper is on and "Open" means the jumper is off the pins.



CMOS Clear

JBT1 on the X14SAE motherboard is used to clear CMOS, which will also clear any passwords. Instead of pins, this jumper consists of contact pads to prevent accidentally clearing the contents of CMOS.

For a detailed diagram of the X14SAE motherboard, see the layout under "[Motherboard Quick Reference](#)" on page 20.



1. First power down the system and unplug the power cord(s).
2. Remove the cover of the chassis to access the motherboard.
3. Remove the onboard battery from the motherboard.
4. Short the CMOS pads, JBT1, with a metal object such as a small screwdriver for at least four seconds.

Note: Clearing CMOS will also clear all passwords.

5. Remove the screwdriver (or shorting device).
6. Replace the cover, reconnect the power cord(s), and power on the system.

CPU PCIe SLOT3 1x8/2x4

Use JPCIESW to configure the bifurcation mode for SLOT3. When changing the SLOT3 bifurcation mode, the SLOT6 bifurcation will also be changed. Refer to the table below for jumpers settings and bifurcation modes between SLOT3 and SLOT6.

For a detailed diagram of the X14SAE motherboard, see the layout under "[Motherboard Quick Reference](#)" on page 20.

JPCIESW Jumper Settings	PCIe SLOT3		PCIe SLOT6
Pins 1–2	1x8 (Default)	Not populated	1x16
Pins 1–2	1x8 (Default)	Populated	1x8
Pins 2–3	2x4	Not populated	1x8
Pins 2–3	2x4	Populated	1x8

External Speaker / Buzzer

On the JD1 header, close pins 3 and 4 with a cap to use the onboard buzzer. If you wish to use an external speaker, close pins 1-4 with a cable.

For a detailed diagram of the X14SAE motherboard, see the layout under "[Motherboard Quick Reference](#)" on page 20.

External Speaker/Buzzer Jumper Settings	
Pin#	Definition
Pins 1–4	External Speaker
Pins 3–4	Buzzer (Default)

HD Audio Enable/Disable

Use JPAC1 to enable or disable HD Audio on the X14SAE motherboard. The default setting is Enabled.

HD Audio Enable/Disable	
Jumper Settings	
Jumper Setting	Definition
Pins 1–2	Enabled (Default)
Pins 2–3	Disabled

LAN Enable/Disable

Use JPL1/JPL2 to enable or disable LAN1/LAN2 on the X14SAE. The default setting is Enabled.

LAN Enable/Disable	
Jumper Settings	
Jumper Setting	Definition
Pins 1–2	Enabled (Default)
Pins 2–3	Disabled

ME Manufacturing Mode

Close pins 2–3 of jumper JPME2 to bypass SPI flash security and force the system to operate in the manufacturing mode, which will allow the user to flash the system firmware from a host server for system setting modifications. Refer to the table below for jumper settings. The default setting is Normal.

For a detailed diagram of the X14SAE motherboard, see the layout under "[Motherboard Quick Reference](#)" on page 20.

ME Manufacturing Mode	
Jumper Settings	
Jumper Setting	Definition
Pins 1–2	Normal (Default)
Pins 2–3	Manufacturing Mode

Onboard TPM Enable/Disable

Use JPT1 to enable or disable the onboard TPM.

For a detailed diagram of the X14SAE motherboard, see the layout under "[Motherboard Quick Reference](#)" on page 20.

TPM Enable/Disable	
Jumper Settings	
Jumper Setting	Definition
Pins 1–2	Enabled (Default)
Pins 2–3	Disabled

Watchdog Timer

Watchdog (JWD1) is a system monitor that can reboot the system when a software application hangs. Close pins 1–2 to reset the system if an application hangs. Close pins 2–3 to generate a non-maskable interrupt (NMI) signal for the application that hangs. The Watchdog must also be enabled in the BIOS.

For a detailed diagram of the X14SAE motherboard, see the layout under "[Motherboard Quick Reference](#)" on page 20.

Watchdog Timer	
Jumper Settings	
Jumper Setting	Definition
Pins 1–2	Reset (Default)
Pins 2–3	NMI
Open	Disabled

4.5 LED Indicators

For information about the LED indicators on the SYS-532AW-C workstation, refer to the following content.

CATERR LED

A CATERR LED is located at CATERR_LED on the X14SAE motherboard. The orange LED indicates the system has experienced a catastrophic error.

For a detailed diagram of the X14SAE motherboard, see the layout under "[Motherboard Quick Reference](#)" on page 20.

CATERR LED Indicator	
LED Color/State	Definition
Orange: On	System CATERR

Each of the LAN1 and LAN2 ports of the rear I/O of the X14SAE motherboard features two LEDs. The LED on the right indicates activity, and the LED on the left indicates the speed of the connection.

LAN1 Speed LED (Left) LED State	
LED Color	Definition
Green	1000 Mbps
Amber	100 Mbps
Off	10 Mbps

LAN2 Speed LED (Left) LED State	
LED Color	Definition
Green	2500 Mbps
Amber	1000 Mbps
Off	100/10 Mbps

LAN1/LAN2 Activity LED (Right) LED State		
LED Color	Status	Definition
Amber	Flashing	1000 Mbps

Onboard Power LED

An Onboard Power LED is located at LEDPWR on the X14SAE motherboard. When LEDPWR is on, the AC power cable is connected and the system is on. When LEDPWR is blinking, it is in standby (S3, suspend to RAM) mode.

For a detailed diagram of the X14SAE motherboard, see the layout under "[Motherboard Quick Reference](#)" on page 20.

Onboard Power LED Indicator	
LED Color	Definition
Off	System Power Off
On	System Power On
Blinking	S3, suspend to RAM

Standby Power

For X14SAE, the LEDBMC works as a standby power LED. When the LED is solid green, the standby power is on.

For a detailed diagram of the X14SAE motherboard, see the layout under "[Motherboard Quick Reference](#)" on page 20.

Standby Power		
Motherboard	LED Color/State	Definition
X14SAE	Green: Solid On	Standby Power On

Chapter 5:

Software

After the SYS-532AW-C workstation has been installed, you can install the Operating System (OS), configure RAID settings, and install the drivers.

5.1 Microsoft Windows OS Installation	80
Installing the OS	80
5.2 Driver Installation	82

5.1 Microsoft Windows OS Installation

If you will be using RAID, you must configure RAID settings before installing the Windows OS and the RAID driver. Refer to the RAID Configuration User Guides posted on our website at <https://www.supermicro.com/support/manuals>.

Installing the OS

1. Create a method to access the Microsoft Windows installation ISO file. That can be a USB flash or media drive, or the BMC KVM console.
2. Retrieve the proper drivers. Go to the Supermicro web page for your motherboard and click on "Download the Latest Drivers and Utilities," select the proper driver, and copy it to a USB flash drive.
3. Boot from a bootable device with Windows OS installation. You can see a bootable device list by pressing <F11> during the system bootup.

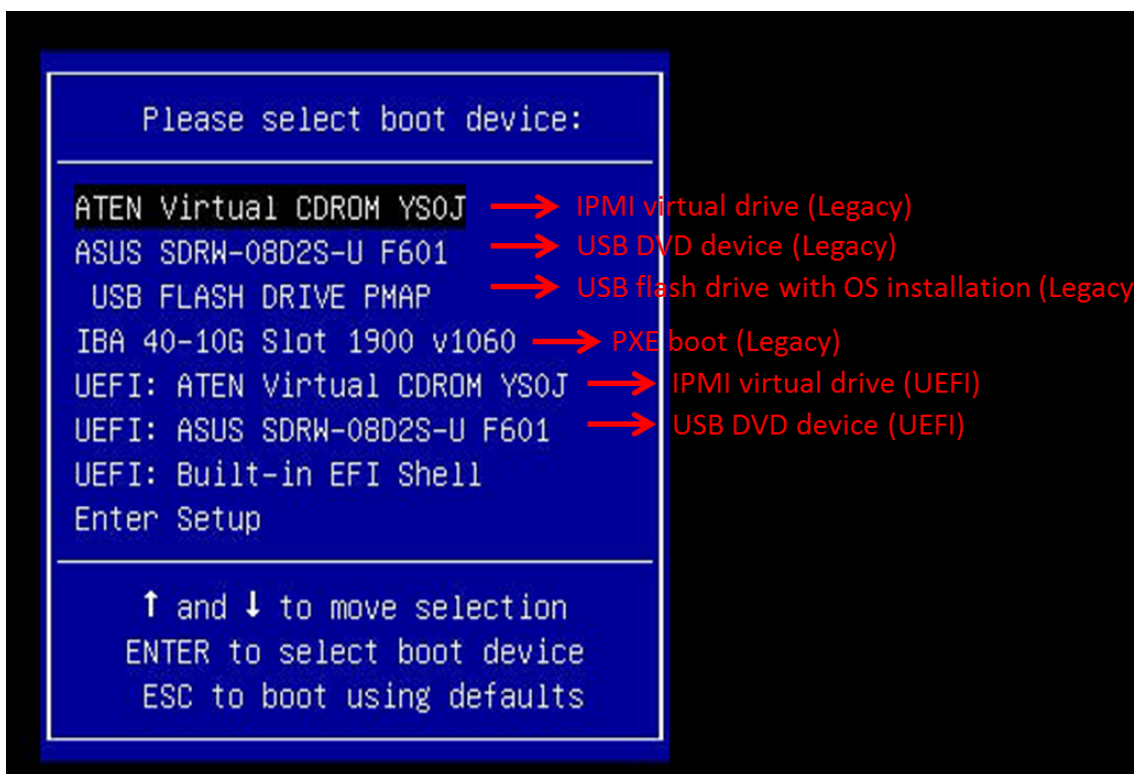

Figure 5-1. Select Boot Device

4. During Windows Setup, continue to the dialog box where you select the drives on which to install Windows. If the disk you want to use is not listed, click on the "Load driver" link at the bottom left corner.

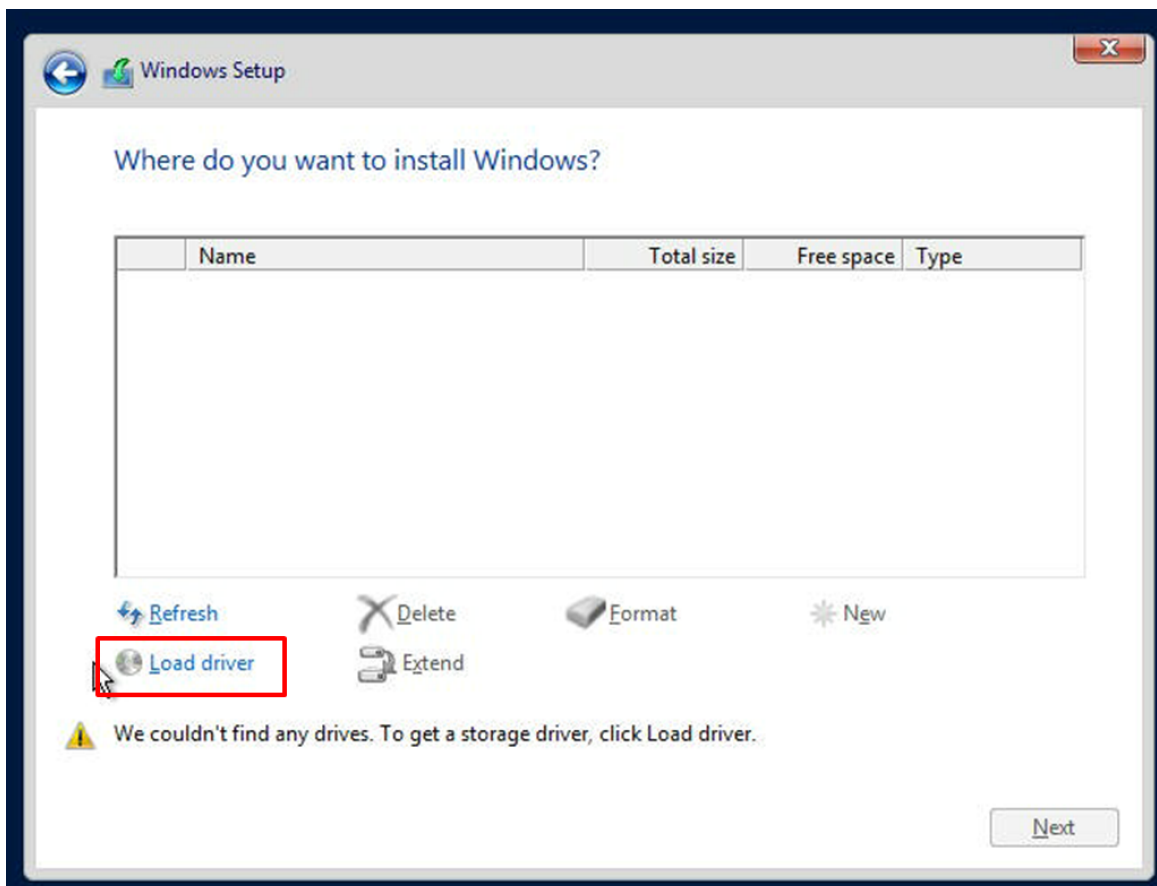

Figure 5-2. Load Driver Link

To load the driver, browse the USB flash drive for the proper driver files.

5. Once all devices are specified, continue with the installation.
6. After the Windows OS installation has completed, the system will automatically reboot multiple times for system updates.

5.2 Driver Installation

The Supermicro website contains drivers and utilities for your system at the following page:

<https://www.supermicro.com/wdl>.

Some of these drivers and utilities must be installed, such as the chipset driver. After accessing the website, go into the CDR_Images (in the parent directory of the above link) and locate the ISO file for your motherboard. Download this file to a USB flash or media drive. You may also use a utility to extract the ISO file if preferred.

Another option is to go to the Supermicro website at <https://www.supermicro.com>. Find the product page for your motherboard and download the latest drivers and utilities.

Insert the flash drive or disk, and the screenshot shown below should appear.

Note: Click the icons showing a hand writing on paper to view the readme files for each item. Click the computer icons to the right of these items to install each item (from top to bottom) one at a time. *After installing each item, you must reboot the system before moving on to the next item on the list.* The bottom icon with a CD on it allows you to view the entire contents.

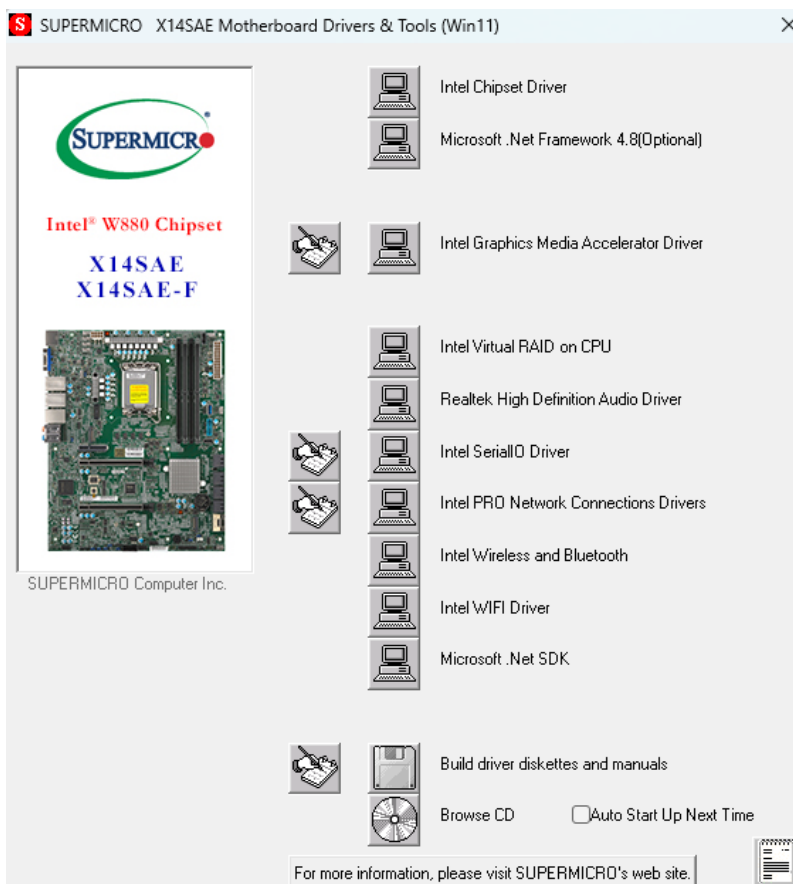

Figure 5-3. Driver & Tools Installation Screen

Chapter 6:

Optional Components

This chapter describes alternate configurations and optional system components for the SYS-532AW-C workstation.

6.1 Optional Parts List	85
--------------------------------------	-----------

6.1 Optional Parts List

Description	Part Number	Quantity
SlimSAS x8 to PCIe 2x SFF-8639 for two PCIe Gen4 NVMe SSDs	CBL-SAST-0953-1	1

Chapter 7:

Troubleshooting and Support

The following content contains information on common issues and how to resolve them.

7.1 Online Resources	87
Direct Links for the SYS-532AW-C System	87
Direct Links for General Support and Information	87
7.2 Troubleshooting Procedures	88
Before Power On	88
No Power	88
No Video	88
System Boot Failure	88
Memory Errors	89
Losing the System's Setup Configuration	89
If the System Becomes Unstable	89
7.3 CMOS Clear	91
7.4 Motherboard Battery	92
7.5 Where to Get Replacement Components	93
7.6 Technical Support Procedures	94
Returning Merchandise for Service	94
7.7 Feedback	96

7.1 Online Resources

A great deal of information is available on the Supermicro website. From the top menu of the Supermicro home page at <https://www.supermicro.com>:

- Specifications for servers and other hardware are available by clicking **Products**.
- The **Support** option offers downloads (manuals, BIOS/BMC, drivers, etc.), FAQs, RMA, warranty, and other service extensions.

Direct Links for the SYS-532AW-C System

- X14SAE motherboard page for links to the quick reference guide, user manual, validated storage drives, and more:
<https://www.supermicro.com/en/products/motherboard/x14sae>

Direct Links for General Support and Information

- Frequently Asked Questions: <https://www.supermicro.com/FAQ/index.php>
- Product Resources page for validated memory details:
<https://www.supermicro.com/support/resources/mem.cfm>
- Product Matrices page for links to tables summarizing specs for systems, motherboards, power supplies, riser cards, add-on cards, and more:
<https://www.supermicro.com/en/support/product-matrices>
- Security Center for recent security notices:
https://www.supermicro.com/en/support/security_center
- Supermicro Phone and Addresses: <https://www.supermicro.com/en/about/contact>

7.2 Troubleshooting Procedures

Use the following procedures to troubleshoot your system. If you have followed all of the procedures below and still need assistance, refer to the ["Technical Support Procedures" on page 94](#) section in this chapter. Always disconnect the AC power cord before adding, changing or installing any non hot-swap hardware components. If the below steps do not fix the setup configuration problem, contact your vendor for repairs.

Before Power On

1. Make sure that there are no short circuits between the motherboard and chassis.
2. Disconnect all ribbon/wire cables from the motherboard, including those for the keyboard and mouse.
3. Remove all add-on cards.
4. Install the processor (making sure it is fully seated) and connect the front panel connectors to the motherboard.

No Power

1. Make sure that there are no short circuits between the motherboard and the chassis.
2. The battery on your motherboard may be old. Check to verify that it still supplies approximately 3 VDC. If it does not, replace it with a new one.

No Video

1. If the power is on, but you do not have video, remove all add-on cards and cables.
2. Remove all memory modules and turn on the system (if the alarm is on, check the specs of memory modules, reset the memory, or try a different one).

System Boot Failure

If the system does not display Power-On-Self-Test (POST) or does not respond after the power is turned on, do the following:

1. Remove all components from the motherboard, especially the DIMMs. Power on the system and check if the power-on LED and the BMC Heartbeat LED are on, and system fans are spinning.

2. Turn on the system with only one DIMM installed. If the system boots, check for bad DIMMs or slots by following the Memory Errors Troubleshooting procedure in this chapter.

Memory Errors

When suspecting faulty memory is causing the system issue, check the following:

1. Make sure that the memory modules are compatible with the system and are properly installed. See "[Maintenance and Component Installation](#)" on [page 28](#) for installation instructions. (For memory compatibility, refer to the "Tested Memory List" link on the motherboard's product page to see a list of supported memory.)
2. Check if different speeds of DIMMs have been installed. It is strongly recommended that you use the same RAM type and speed for all DIMMs in the system.
3. Make sure that you are using the correct type of DIMMs recommended by the manufacturer.
4. Check for bad DIMMs or slots by swapping a single module among all memory slots and check the results.

Losing the System's Setup Configuration

1. Make sure that you are using a high-quality power supply. A poor-quality power supply may cause the system to lose the CMOS setup information. Refer to "[Introduction](#)" on [page 12](#) for details on recommended power supplies.
2. The battery on your motherboard may be old. Check to verify that it still supplies approximately 3 VDC. If it does not, replace it with a new one.

If the System Becomes Unstable

- A. If the system becomes unstable during or after OS installation, check the following:
 1. Processor/BIOS support: Make sure that your processor is supported and that you have the latest BIOS installed in your system.
 2. Memory support: Make sure that the memory modules are supported. Refer to the product page on our website at <https://www.supermicro.com>. Test the modules using memtest86 or a similar utility.

Note: Click on the "Tested Memory List" link on the motherboard's product page to see a list of supported memory.

3. Storage Drive support: Make sure that all storage drives work properly. Replace the failed storage drives with good ones.
 4. System cooling: Check the system cooling to make sure that all heatsink fans and processor/system fans, etc., work properly. Check the hardware monitoring settings in the BMC to make sure that the processor and system temperatures are within the normal range. Also, check the front panel Overheat LED and make sure that it is not on.
 5. Adequate power supply: Make sure that the power supply provides adequate power to the system. Make sure that all power connectors are connected. Refer to our website for more information on the minimum power requirements.
 6. Proper software support: Make sure that the correct drivers are used.
- B. If the system becomes unstable before or during OS installation, check the following:
1. Source of installation: Make sure that the devices used for installation are working properly, including boot devices such as a CD/Media drive.
 2. Cable connection: Check to make sure that all cables are connected and working properly.
 3. Use the minimum configuration for troubleshooting: Remove all unnecessary components (starting with add-on cards first), and use the minimum configuration (but with the processor and a memory module installed) to identify the trouble areas. Refer to the steps listed above in this section for proper troubleshooting procedures.
 4. Identify bad components by isolating them: If necessary, remove a component in question from the chassis, and test it in isolation to make sure that it works properly. Replace a bad component with a good one.
 5. Check and change one component at a time instead of changing several items at the same time. This will help isolate and identify the problem.
 6. To find out if a component is good, swap this component with a new one to see if the system will work properly. If so, then the old component is bad. You can also install the component in question in another system. If the new system works, the component is good and the old system has problems.

7.3 CMOS Clear

JBT1 on the X14SAE motherboard is used to clear CMOS, which will also clear any passwords. For information on clearing CMOS, refer to ["CMOS Clear" on page 73](#) earlier in this manual.

7.4 Motherboard Battery

For information on removing, disposing of, and replacing the motherboard battery of your system, refer to ["Motherboard Battery Removal and Installation" on page 53](#).

7.5 Where to Get Replacement Components

If you need replacement parts for your SYS-532AW-C workstation, to ensure the highest level of professional service and technical support, purchase exclusively from our Supermicro Authorized Distributors/System Integrators/Resellers. A list can be found on the Supermicro website:

<https://www.supermicro.com>

Under the "Buy" menu, click the "Where to Buy" link.

7.6 Technical Support Procedures

Before contacting Technical Support, take the following steps. Also, note that as a motherboard manufacturer, Supermicro also sells motherboards through its channels, so it is best to first check with your distributor or reseller for troubleshooting services. They should know of any possible problems with the specific system configuration that was sold to you.

1. Refer to "Troubleshooting Procedures" on page 88 or see the FAQs on our website (<https://www.supermicro.com/FAQ/index.php>) before contacting Technical Support.
2. BIOS upgrades can be downloaded from our website (https://www.supermicro.com/support/resources/bios_ipmi.php).
3. If you still cannot resolve the problem, include the following information when contacting Supermicro for technical support:
 - Motherboard model and PCB revision number
 - BIOS release date/version (This can be seen on the initial display when your system first boots up.)
 - System configuration
4. An example of a Technical Support form is on our website at <https://webpr3.supermicro.com/SupportPortal>.
5. Distributors: For immediate assistance, have your account number ready when placing a call to our Technical Support department. For Supermicro contact information, refer to "Contacting Supermicro" on page 11.

Returning Merchandise for Service

A receipt or copy of your invoice marked with the date of purchase is required before any warranty service will be rendered. You can obtain service by calling your vendor for a Returned Merchandise Authorization (RMA) number. When returning the workstation to the manufacturer, the RMA number should be prominently displayed on the outside of the shipping carton, and the shipping package is mailed prepaid or hand-carried. Shipping and handling charges will be applied for all orders that must be mailed when service is complete.

For faster service, RMA authorizations can be requested online at the following page:

<https://www.supermicro.com/RmaForm>

Whenever possible, repack the workstation in the original Supermicro carton, using the original packaging material. If these are no longer available, be sure to pack the workstation securely, using packaging material to surround the workstation so that it does not shift within the carton and become damaged during shipping.

This warranty only covers normal consumer use and does not cover damages incurred in shipping or from failure due to the alternation, misuse, abuse or improper maintenance of products.

During the warranty period, contact your distributor first for any product problems.

7.7 Feedback

Supermicro values your feedback as we strive to improve our customer experience in all facets of our business. Email us at Techwriterteam@supermicro.com to provide feedback on our manuals.

Chapter 8:

UEFI BIOS

The following content contains information on BIOS configuration with the SYS-532AW-C workstation.

8.1 Introduction	98
8.2 Main Setup	100
8.3 Advanced Setup Configurations	102
8.4 Event Logs	136
8.5 Security	138
8.6 Boot	144
8.7 Save & Exit	146
8.8 MEBx	148

8.1 Introduction

This chapter describes the AMIBIOS™ Setup utility for the motherboard. The BIOS is stored on a chip and can be easily upgraded using the UEFI script (flash.nsh), the BMC WebUI, or the SuperServer Automation Assistant (SAA) utility.

Note: Due to periodic changes to the BIOS, some settings may have been added or deleted and might not yet be recorded in this manual. Refer to the Manual Download area of our website for any changes to BIOS that may not be reflected in this manual.

Updating BIOS

It is recommended that you do not upgrade your BIOS if you are not experiencing any problems with your system. Updated BIOS files are located on our website at the following page:

https://www.supermicro.com/support/resources/bios_ipmi.php

Check our BIOS warning message and the information on how to update your BIOS on our website. Select your motherboard model and download the BIOS file to your computer. Also, check the current BIOS revision to make sure that it is newer than your BIOS before downloading.

Important: Do not shut down or reset the system while updating the BIOS to prevent possible system boot failure! Read the motherboard README file carefully before you perform the BIOS update.

Unzip the BIOS file onto a USB device formatted with the FAT/FAT32 file system. When the UEFI shell prompt appears, type `fs#` to change the device directory path. Go to the directory that contains the BIOS package you extracted earlier. Enter `flash.nsh BIOSname#.###` at the prompt to start the BIOS update process. Reboot the system when you see the message that BIOS update has completed.

Starting the Setup Utility

To enter the BIOS Setup utility, press the <Delete> key while the system is booting-up. In most cases, the <Delete> key is used to invoke the BIOS Setup screen. There are a few cases when other hot keys are used, such as <F1>, <F2>, etc. Each main BIOS menu option is described in this manual.

The Main BIOS screen has two main frames. The left frame displays all the options that can be configured. “Grayed-out” options cannot be configured. The right frame displays the key legend. Above the key legend is an area reserved for a text message. When a BIOS submenu

or item is selected in the left frame, it is highlighted in white. Often a text message will accompany it. (Note that BIOS has default text messages built in. We retain the option to include, omit, or change any of these text messages.) Settings printed in **Bold** are the default values.

A "▶" indicates a submenu. Highlighting such an item and pressing the <Enter> key open the list of settings within that submenu.

The BIOS Setup utility uses a key-based navigation system called hot keys. Most of these hot keys (<F1>, <F2>, <F3>, <F4>, <F5>, <F6>, <Enter>, <ESC>, the arrow keys, etc.) can be used at any time during the setup navigation process.

8.2 Main Setup

The Main setup screen appears when the AMI BIOS Setup utility is first entered. To return to the Main setup screen, select the Main tab at the top of the screen. The Main BIOS setup screen is shown below.

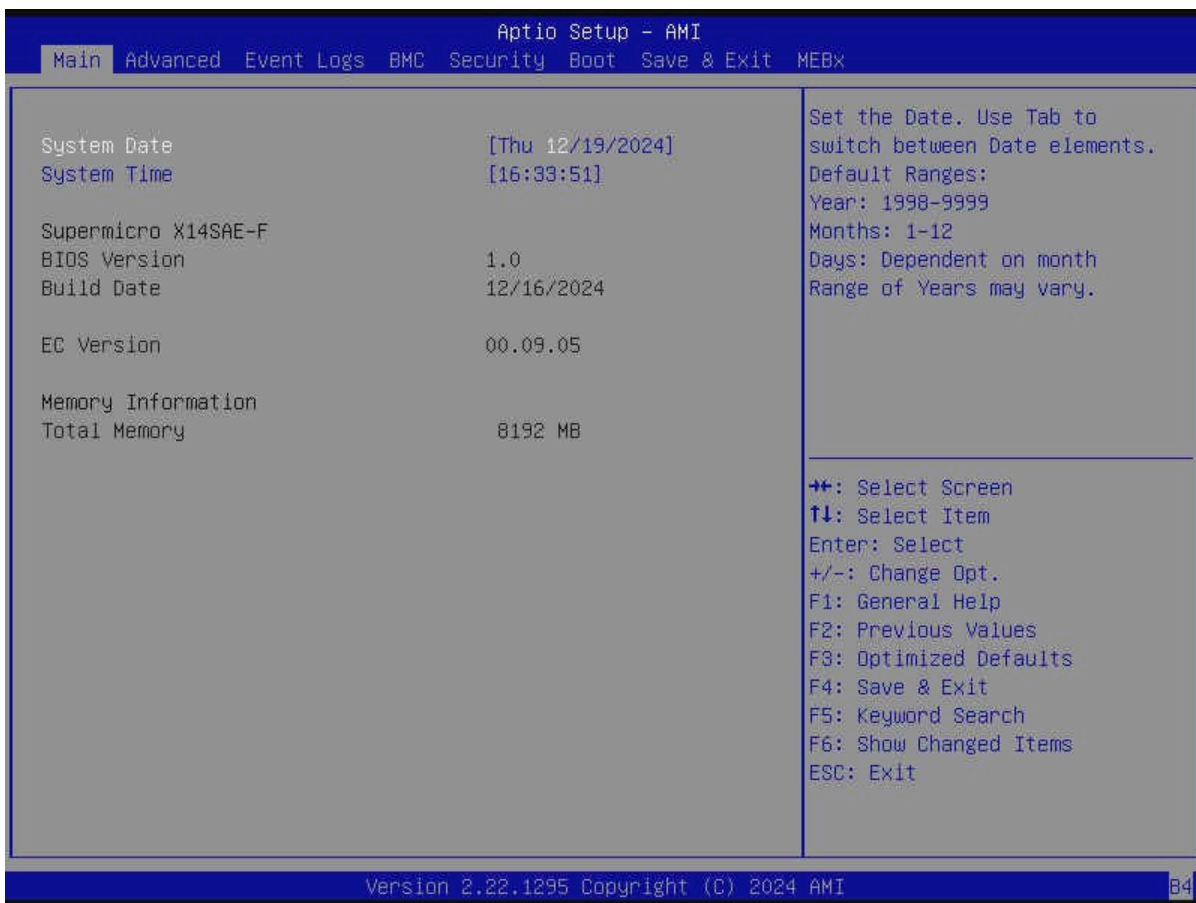

Figure 8-1. Main Screen

System Date/System Time

Use the two features to change the system date and time. Highlight **System Date** or **System Time** using the arrow keys. Enter new values using the keyboard. Press the <Tab> key or the arrow keys to move between fields. The date must be entered in MM/DD/YYYY format. The time is entered in HH:MM:SS format.

Note: The time is in the 24-hour format. For example, 5:30 P.M. appears as 17:30:00.

SupermicroX14SAE

BIOS Version

This feature displays the version of the BIOS ROM used in the system.

Build Date

This feature displays the date when the version of the BIOS ROM used in the system was built.

EC Version

This feature displays the version of the Embedded Controller (EC) used in the system.

Memory Information

Total Memory

This feature displays the total size of memory available in the system.

8.3 Advanced Setup Configurations

Use the arrow keys to select the Advanced submenu and press <Enter> to access the submenu items.

Important: Use caution when changing the Advanced settings. An incorrect value, an improper DRAM frequency, or a wrong BIOS timing setting may cause the system to malfunction. When this occurs, revert the setting to the manufacture default settings.

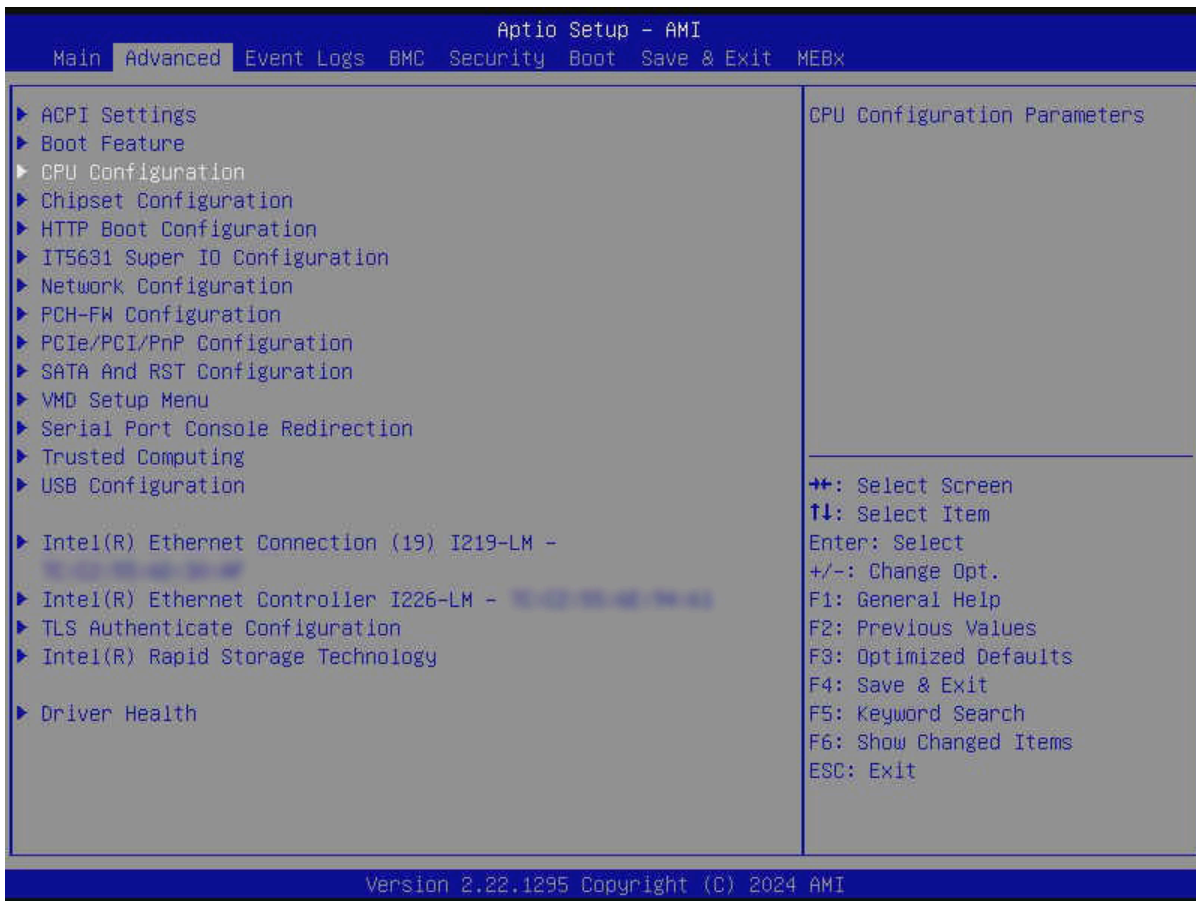

Figure 8-2. Advanced Setup Configuration Screen

ACPI Settings Menu

▶ ACPI Settings

ACPI Sleep State

Use this feature to select the ACPI Sleep State that the system will enter into when the suspend button is activated. The options are Suspend Disabled and **S3 (Suspend to RAM)**.

WHEA Support

Select Enabled to support the Windows Hardware Error Architecture (WHEA) platform and provide a common infrastructure for the system to handle hardware errors within the Windows OS environment to reduce system crashes and to enhance system recovery and health monitoring. The options are Disabled and **Enabled**.

High Precision Event Timer

Select Enabled to activate the High Precision Event Timer (HPET) that produces periodic interrupts at a much higher frequency than a Real-time Clock (RTC) does in synchronizing multimedia streams, providing smooth playback and reducing the dependency on other timestamp calculation devices, such as an x86 RDTSC Instruction embedded in the CPU. The High Performance Event Timer is used to replace the 8254 Programmable Interval Timer. The options are Disabled and **Enabled**.

Native PCIe Enable

Enable this feature to grant control of PCI Express Native hot plug, PCI Express Power Management Events, and PCI Express Capability Structure Control. The options are Disabled and **Enabled**.

Native ASPM

Select Enabled for the operating system to control the ASPM, or Disabled for the BIOS to control the ASPM. The options are Auto, Enabled, and **Disabled**.

Boot Feature Menu

► Boot Feature

Fast Boot

This feature enables the system to boot with a minimal set of required devices to launch. This has no effect on BBS boot options. The options are **Disabled** and Enabled.

Quiet Boot

Use this feature to select the screen between displaying the Power-on Self Test (POST) messages or the OEM logo upon bootup. Select Disabled to display the POST messages. Select Enabled to display the OEM logo instead of the normal POST messages. The options are Disabled and **Enabled**.

Note: BIOS POST messages are always displayed regardless of the setting of this feature.

Bootup NumLock State

Use this feature to set the Power-on state for the <Numlock> key. The options are **On** and Off.

Wait For "F1" If Error

Select Enabled to force the system to wait until the <F1> key is pressed if an error occurs. The options are **Disabled** and Enabled.

Re-try Boot

If this feature is set to Enabled, the system BIOS will automatically reboot the system from an Extensible Firmware Interface (EFI) boot device after an initial boot failure. The options are **Disabled** and Enabled.

Power Configuration

Watch Dog Function

Select Enabled to allow the Watch Dog timer to reboot the system when it is inactive for more than five minutes. The options are **Disabled** and Enabled.

Watch Dog Action (Available when "Watch Dog Function" is set to Enabled)

Use this feature to configure the Watch Dog Time_out setting. The options are **Reset** and NMI.

DeepSx Power Policies

Use this feature to configure the Advanced Configuration and Power Interface (ACPI) settings for the system. Enable S4 to use Hibernation mode (Suspend to Disk) so that all data stored in the main memory can be saved in a non-volatile memory area such as in a hard drive and then

power down the system. Enable S5 to power off the whole system except the power supply unit (PSU) and keep the power button alive so that you can wake up the system by using a USB keyboard or mouse. The options are **Disabled**, Enabled In S4-S5, and Enabled in S5.

Delay Time Before PCI Enumeration

Use this feature to set the amount of time the system waits before enumerating PCI devices during the boot process. The valid range is 0–30 with a step of 1 second. The default setting is **0** for off, meaning the system will skip the delay time and immediately begin enumerating PCI devices.

CPU Configuration Menu

► CPU Configuration

Important: Setting the wrong values for the features included in the following sections may cause the system to malfunction.

The following processor information is displayed.

- CPU Signature
- Microcode Patch
- Max CPU Speed
- Min CPU Speed
- CPU Speed
- Number of Performance-core(s)
- Number of Efficient-core(s)
- Hyper Threading Technology
- VMX
- SMX/TXT
- 64-bit
- EIST Technology
- CPU C3–C10 State
- Performance L1 Data Cache
- Performance L1 Instruction Cache
- Performance L2 Cache
- Performance L3 Cache
- Efficient L1 Data Cache
- Efficient L1 Instruction Cache
- Efficient L2 Cache
- Efficient L3 Cache

Intel Virtualization Technology

Select Enabled to enable the Intel Vanderpool Technology for Virtualization platform support, which allows multiple operating systems to run simultaneously on the same computer to maximize system resources for performance enhancement. The options are Disabled and **Enabled**. Changes take effect after you save settings and reboot the system.

Active Performance-cores

This feature determines how many performance cores will be activated for each processor package. When all is selected, all cores in the processor will be activated. The options are **All**, 7, 6, 5, 4, 3, 2, and 1.

Active Efficient-cores

This feature determines how many efficient cores will be activated for each processor package. When all is selected, all cores in the processor will be activated. The options are **All**, 15, 14, 13, 12, 11, 10, 9, 8, 7, 6, 5, 4, 3, 2, and 1.

Note: The number of cores depend on the processor used in the system.

AES

Select Enabled to use the Intel Advanced Encryption Standard (AES) to ensure data security. The options are Disabled and **Enabled**.

Boot Performance Mode

This feature allows you to select the performance state that the BIOS will set before the operating system handoff. The options are **Max Non-Turbo Performance** and Turbo Performance.

Intel® SpeedStep™

Intel SpeedStep Technology allows the system to automatically adjust processor voltage and core frequency to reduce power consumption and heat dissipation. The options are Disabled and **Enabled**.

Intel® Speed Shift Technology

Use this feature to enable or disable Intel Speed Shift Technology support. When this feature is enabled, the Collaborative Processor Performance Control (CPPC) version 2 interface will be available to control CPU P-States. The options are Disabled and **Enabled**.

Turbo Mode (Available when "Intel SpeedStep" or "Intel Speed Shift Technology" is set to Enabled)

Select Enabled to allow the CPU to operate at the manufacturer-defined turbo speed by increasing CPU clock frequency. This feature is available when it is supported by the processors used in the system. The options are Disabled and **Enabled**.

Power Limit 1 Override

Select Enabled to support average power limit (PL1) override. The options are **Disabled** and Enabled.

Power Limit 2 Override

Select Enabled to support rapid power limit (PL2) override. The options are Disabled and **Enabled**.

Power Limit 2

Use this feature to configure the value for Power Limit 2. The value is in milliwatts and the step size is 125 mW. Use the number keys on your keyboard to enter the value. Enter 0 to use the manufacture default setting. If the value is 0, the BIOS will set PL2 as 1.25* TDP.

C-States

Use this feature to enable the C-State of the CPU. The options are Disabled and **Enabled**.

Enhanced C-States

Use this feature to enable the enhanced C-State of the CPU. The options are Disabled and **Enabled**.

C-State Auto Demotion

Use this feature to prevent unnecessary excursions into the C-states to improve latency. The options are Disabled and **C1**.

C-State Un-Demotion

This feature allows you to enable or disable the un-demotion of C-State. The options are Disabled and **C1**.

Package C-State Demotion

Use this feature to enable or disable the Package C-State demotion. The options are Disabled and **Enabled**.

Package C-State Un-Demotion

Use this feature to enable or disable the Package C-State un-demotion. The options are Disabled and **Enabled**.

C-State Pre-Wake

This feature allows you to enable or disable the C-State Pre-Wake. The options are Disabled and **Enabled**.

Package C-State Limit

Use this feature to set the Package C-State limit. The options are C0/C1, C2, C3, C6, C7, C7s, C8, C9, C10, Cpu Default, and **Auto**.

Monitor MWAIT

Select Enabled to support Monitor and Mwait, which are two instructions in Streaming SIMD Extension 3 (SSE3) to improve synchronization between multiple threads for CPU performance enhancement. The options are Disabled and **Enabled**.

Performance Mode

Select Enabled for optimal performance, which may increase the risk of CPU overheating. Select Disabled for thermal safety, which may limit CPU performance. The options are **Disabled** and Enabled.

Chipset Configuration Menu

► Chipset Configuration

Important: Setting the wrong values in this section may cause the system to malfunction.

System Agent (SA) Configuration Menu

► System Agent (SA) Configuration

Vt-d

This feature displays if Vt-d is enabled or disabled.

VT-d

Select Enabled to activate Intel Virtualization Technology support for Direct I/O VT-d by reporting the I/O device assignments to VMM through the DMAR ACPI Tables. This feature offers fully-protected I/O resource-sharing across the Intel platforms, providing the user with greater reliability, security and availability in networking and data-sharing. The options are **Enabled** and Disabled.

X2APIC Enable

Use this feature to enable or disable the Advanced Programmable Interrupt Controller (X2APIC) operating mode. The options are Disabled and **Enabled**.

DMA Control Guarantee

Use this feature to enable or disable DMA Control Guarantee bit. The options are **Enabled** and Disabled.

Memory Configuration Menu

► Memory Configuration

This submenu is used to configure the Integrated Memory Controller (IMC) settings.

- Memory RC Version
- Memory Frequency
- Memory Timings (tCL-tRCD-tRP-tRAS)
- DIMMA1
- DIMMA2

- DIMMB1
- DIMMB2

Maximum Memory Frequency

Use this feature to set the maximum memory frequency for onboard memory modules. The options are **Auto**, 1600, 2400, 3200, 3600, 4000, 4200, 4400, 4600, 4800, 5000, 5200, 5400, 5600, 5800, 6000, 6200, and 6400.

Max TOLUD

This feature sets the maximum TOLUD value, which specifies the "Top of Low Usable DRAM" memory space to be used by internal graphics devices, GTT Stolen Memory, and TSEG, respectively, if these devices are enabled. The options are **Dynamic**, 1 GB, 1.25 GB, 1.5 GB, 1.75 GB, 2 GB, 2.25 GB, 2.5 GB, 2.75 GB, 3 GB, 3.25 GB, and 3.5 GB.

Memory Scrambler

Use this feature to enable or disable memory scrambler support. The options are Disabled and **Enabled**.

Force ColdReset

Use this feature to enable or disable a cold boot during a MRC execution. The options are Enabled and **Disabled**.

Force Single Rank

Select enabled to use only Rank 0 in each DIMM. The options are **Disabled** and Enabled.

Memory Remap

Use this feature to enable or disable memory remap above 4 GB. The options are **Enabled** and Disabled.

MRC Fast Boot

Use this feature to enable or disable fast path through the memory reference code. The options are Disabled and **Enabled**.

Total Memory Encryption

Use this feature to enable or disable Total Memory Encryption (TME). When enabled, Intel TME enhances memory data security. The options are **Disabled** and Enabled.

Graphics Configuration Menu

► Graphics Configuration

This submenu allows you to configure the graphics configuration settings.

Graphics Configuration

IGFX GOP Version

Skip Scanning of External Gfx Card

If this feature is enabled, the system will not scan for an external graphics card on PEG and PCIe slots. The options are **Disabled** and **Enabled**.

Primary Display

Use this feature to select the primary video display. The options are **Auto** and **IGFX**.

Internal Graphics

Select **Auto** to keep an internal graphics device installed on an expansion slot supported by the CPU to be automatically enabled. The options are **Auto**, **Disabled**, and **Enabled**.

DVMT Pre-Allocated

Dynamic Video Memory Technology (DVMT) allows dynamic allocation of system memory to be used for video devices to ensure best use of available system memory based on the DVMT 5.0 platform. The options are 0M, 32M, 64M, 96M, **128M**, 4M, 8M, 12M, 16M, 20M, 24M, 28M, 32M/F7, 36M, 40M, 44M, 48M, 52M, 56M, and 60M.

Configure GT for use

Use this feature to enable or disable GT configuration. The options are **Disabled** and **Enabled**.

PAVP Enable

Use this feature to enable or disable PAVP support. The options are **Disabled** and **Enabled**.

DMI Configuration Menu

► **DMI Configuration**

This submenu allows you to configure the DMI configuration settings.

DMI ASPM

Use this feature to set the Active State Power Management (ASPM) state on the System Agent (SA) side of the DMI Link. The options are **Disabled**, **ASPM L1**, and **Auto**.

PEG Port Configuration

► **PEG Port Configuration**

CPU SLOT6 PCIe 5.0 x16

CPU SLOT3 PCIe 5.0 x8 (IN X16)

CPU SLOT3 PCIe 5.0 x8 (IN X16)

When a device is detected in the corresponding slot, the BIOS displays the device information.

Note: If CPU SLOT3 is populated with a PCIe 1x8 device, the device information appears in the first "CPU SLOT3 PCIE 5.0 X8 (IN X16)" feature. When CPU SLOT3 is populated with a PCIe 2x4 device, the device information appears in both "CPU SLOT3 PCIE 5.0 X8 (IN X16)" features.

Enable Root Port

Use this feature to enable or disable the PCIe port. The options are Disabled and **Enabled**.

Max Link Speed

Use this feature to select the maximum link speed for the PCIe port. The options are **Auto**, Gen1, Gen2, Gen3, Gen4, and Gen5.

CPU SLOT7 PCIe 4.0 x4

Enable Root Port

Use this feature to enable or disable the PCIe port. The options are Disabled and **Enabled**.

Max Link Speed

Use this feature to select the maximum link speed for the PCIe port. The options are **Auto**, Gen1, Gen2, Gen3, and Gen4.

M.2-C1

When a device is detected in the specified slot, the BIOS displays the device information.

Enable Root Port

Use this feature to enable or disable the PCIe port. The options are Disabled and **Enabled**.

Max Link Speed

Use this feature to select the maximum link speed for the PCIe port. The options are **Auto**, Gen1, Gen2, Gen3, Gen4, and Gen5.

GT - Power Management Control

GT - Power Management Control

RC6 (Render Standby)

Use this feature to enable render standby support. The options are Disabled and **Enabled**.

Maximum GT Frequency

Use this feature to define the Maximum GT frequency. Choose between 1650 MHz (RPN) and 6000 MHz (RP0). Any value beyond this range will be clipped to its min/max supported by the CPU. The options are **Default Max Frequency**, 100Mhz, 150Mhz, 200Mhz, 250Mhz, 300Mhz, 350Mhz, 400Mhz, 450Mhz, 500Mhz, 550Mhz, 600Mhz, 650Mhz, 700Mhz, 750Mhz, 800Mhz, 850Mhz, 900Mhz, 950Mhz, 100Mhz, 1050Mhz, 1100Mhz, 1150Mhz, and 1200Mhz.

Disable Turbo GT Frequency

Use this feature to disable Turbo GT frequency. If set to Enabled, Turbo GT frequency becomes disabled. If set to Disabled, GT frequency limiters will be removed. The options are Enabled and **Disabled**.

PCH-IO Configuration Menu

PCH-IO Configuration

The following information is displayed.

- PCH SKU
- Stepping

Frontside Audio Mode

Use this feature to configure the audio mode for the Front Audio Header. The audio header's default setting is for a headphone/microphone combo jack. Select HD Audio if the audio header is connected to HD Audio port. Select AC'97 if the audio header is connected to AC'97 audio port. The options are HD Audio, AC' 97 and **Combo Jack**.

PCI Express Configuration

PCI Express Configuration

▶ Onboard LAN2

▶ SLIMSAS_8I Port0

▶ SLIMSAS_8I Port1

▶ M.2-P1

ASPM

Use this feature to activate the Active State Power Management (ASPM) level for a PCIe device. Select Auto for the system BIOS to automatically set the ASPM level based on the system configuration. Select Disabled to disable ASPM support. The options are Disabled, **L1**, and Auto.

L1 Substates

Use this feature to set the PCI Express L1 Substate. The options are Disabled, L1.1 and **L1.1 & L1.2**.

PCIe Speed

Use this feature to set the PCI Express port speed. The options are **Auto**, Gen1, Gen2, Gen3, and Gen4.

Peer Memory Write Enable

Use this feature to enable or disable Peer Memory Write. The options are **Disabled** and Enabled.

HTTP Boot Configuration Menu

► HTTP Boot Configuration

HTTP Boot Policy

Use this feature to set the HTTP boot policy. The options are Apply to all LANs, **Apply to each LAN**, and Boot Priority #1 instantly.

HTTPS Boot Checks Hostname

Important: Disabling "HTTPS Boot Checks Hostname" is a violation of RFC 6125 and may expose you to Man-in-the-Middle Attacks. Supermicro is not responsible for any and all security risks incurred by you disabling this feature.

Enable this feature for HTTPS boot to check the hostname of the TLS certificates to see if it matches the host name provided by the remote server. The options are **Enabled** and Disabled (WARNING: Security Risk!).

Priority of HTTP Boot

Instance of Priority 1: (Available when your motherboard supports this feature)

This feature sets the rank target port. The default setting is **1**.

Select IPv4 or IPv6

This feature specifies which connection the target LAN port should boot from. The options are **IPv4** and IPv6.

Boot Description

Use this feature to enter a boot description, which cannot be longer than 75 characters. Please be sure to enter a boot description; otherwise, the boot option for the URI cannot be created.

Boot URI

Enter a Boot Uniform Resource Identifier (URI) with 128 characters or shorter. This Boot URI determines how IPv4 Boot Option and IPv6 Boot Option will be created.

Instance of Priority 2: (Available when your motherboard supports this feature)

This feature sets the rank target port. The default setting is **0**.

Super IO Configuration Menu

► Super IO Configuration

The following information is displayed.

- Super IO Chip

Note: This submenu is available when your system supports this feature.

Serial Port 1 Configuration Menu

► Serial Port 1 Configuration

Serial Port 1

Select Enabled to enable serial port 1. The options are Disabled and **Enabled**.

Device Settings (Available when "Serial Port 1" above is set to Enabled)

This feature displays the base I/O port address and the Interrupt Request address of serial port 1.

Change Settings (Available when "Serial Port 1" above is set to Enabled)

Use this feature to specify the base I/O port address and the Interrupt Request address of serial port 1. Select Auto for the BIOS to automatically assign the base I/O and IRQ address to serial port 1. The options are **Auto**, (IO=3F8h; IRQ=4;), (IO=3F8h; IRQ=3,4,5,6,7,9,10,11,12;), (IO=2F8h; IRQ=3,4,5,6,7,9,10,11,12;), (IO=3E8h; IRQ=3,4,5,6,7,9,10,11,12;), and (IO=2E8h; IRQ=3,4,5,6,7,9,10,11,12;).

Network Stack Configuration Menu

► Network Stack Configuration

Network Stack

Select Enabled to enable Preboot Execution Environment (PXE) or Unified Extensible Firmware Interface (UEFI) for network stack support. The options are Disabled and **Enabled**.

IPv4 PXE Support (Available when "Network Stack" is set to Enabled)

Select Enabled to enable IPv4 PXE boot support. If this feature is disabled, it will not create the IPv4 PXE boot option. The options are Disabled and **Enabled**.

IPv4 HTTP Support (Available when "Network Stack" is set to Enabled)

Select Enabled to enable IPv4 HTTP boot support. If this feature is disabled, it will not create the IPv4 HTTP boot option. The options are **Disabled** and Enabled.

IPv6 PXE Support (Available when "Network Stack" is set to Enabled)

Select Enabled to enable IPv6 PXE boot support. If this feature is disabled, it will not create the IPv6 PXE boot option. The options are Disabled and **Enabled**.

IPv6 HTTP Support (Available when "Network Stack" is set to Enabled)

Select Enabled to enable IPv6 HTTP boot support. If this feature is disabled, it will not create the IPv6 HTTP boot option. The options are **Disabled** and Enabled.

PXE Boot Wait Time (Available when "Network Stack" is set to Enabled)

Use this feature to set the wait time (in seconds) upon which the system BIOS will wait for you to press the <ESC> key to abort PXE boot instead of proceeding with PXE boot by connecting to a network server immediately. Press the <+> or <-> key on your keyboard to change the value. The default setting is **0**.

Media Detect Count (Available when "Network Stack" is set to Enabled)

Use this feature to set the wait time (in seconds) for the BIOS ROM to detect the presence of a LAN media either via the Internet connection or via a LAN port. Press the <+> or <-> key on your keyboard to change the value. The default setting is **1**.

MAC:(MAC address)-IPv4 Network Configuration Menu**▶ MAC:(MAC address)-IPv4 Network Configuration****Configured**

Enable this feature to configure network addresses for DHCP, local IP address, local netmask, local gateway, and local DNS server. The options are **Disabled** and Enabled.

Enable DHCP (Available when "Configured" is set to Enabled)

Select Enabled to support Dynamic Host Configuration Protocol (DHCP), which allows the BIOS to search for a DHCP server attached to the network and request the next available IP address for this computer. The options are **Disabled** and Enabled.

Local IP Address (Available when "Configured" is set to Enabled and "Enable DHCP" is set to Disabled)

Use this feature to enter an IP address for the local machine.

Local NetMask (Available when "Configured" is set to Enabled and "Enable DHCP" is set to Disabled)

Use this feature to set the netmask for the local machine.

Local Gateway (Available when "Configured" is set to Enabled and "Enable DHCP" is set to Disabled)

Use this feature to set the gateway address for the local machine.

Local DNS Servers (Available when "Configured" is set to Enabled and "Enable DHCP" is set to Disabled)

Use this feature to set the Domain Name System (DNS) server address for the local machine.

Save Changes and Exit

Press <Enter> to save changes and exit.

MAC:(MAC address)-IPv6 Network Configuration Menu**▶ MAC:(MAC address)-IPv6 Network Configuration****▶ Enter Configuration Menu**

The following information is displayed.

- Interface Name
- Interface Type
- MAC address
- Host address
- Route Table
- Gateway addresses
- DNS addresses

Interface ID

Use this feature to change/enter the 64-bit alternative interface ID for the device. The string format is colon separated. The default setting is the MAC address above.

DAD Transmit Count

Use this feature to set the number of consecutive neighbor solicitation messages have been sent while performing duplicate address detection on a tentative address. The default setting is **1**.

Policy

Use this feature to select how the policy is to be configured. The options are **automatic** and **manual**.

▶ Advanced Configuration

Note: This submenu is available when "Policy" is set to manual.

New IPv6 address: Use this feature to enter the IPv6 address for the local machine.

New Gateway addresses: Use this feature to set the gateway address for the local machine.

New DNS addresses: Use this feature to set the DNS server address for the local machine.

Commit Changes and Exit: Press <Enter> to save changes and exit.

Discard Changes and Exit: Press <Enter> to discard changes and exit.

Save Changes and Exit

Press <Enter> to save changes and exit.

MAC:(MAC address)-IPv4 Network Configuration Menu

► MAC:(MAC address)-IPv4 Network Configuration

Configured

Enable this feature to configure network addresses for DHCP, local IP address, local netmask, local gateway, and local DNS server. The options are **Disabled** and **Enabled**.

Enable DHCP (Available when "Configured" is set to Enabled)

Select **Enabled** to support Dynamic Host Configuration Protocol (DHCP), which allows the BIOS to search for a DHCP server attached to the network and request the next available IP address for this computer. The options are **Disabled** and **Enabled**.

Local IP Address (Available when "Configured" is set to Enabled and "Enable DHCP" is set to Disabled)

Use this feature to enter an IP address for the local machine.

Local NetMask (Available when "Configured" is set to Enabled and "Enable DHCP" is set to Disabled)

Use this feature to set the netmask for the local machine.

Local Gateway (Available when "Configured" is set to Enabled and "Enable DHCP" is set to Disabled)

Use this feature to set the gateway address for the local machine.

Local DNS Servers (Available when "Configured" is set to Enabled and "Enable DHCP" is set to Disabled)

Use this feature to set the Domain Name System (DNS) server address for the local machine.

Save Changes and Exit

Press <Enter> to save changes and exit.

MAC:(MAC address)-IPv6 Network Configuration Menu

▶ MAC:(MAC address)-IPv6 Network Configuration

▶ Enter Configuration Menu

The following information is displayed.

- Interface Name
- Interface Type
- MAC address
- Host address
- Route Table
- Gateway addresses
- DNS addresses

Interface ID

Use this feature to change/enter the 64-bit alternative interface ID for the device. The string format is colon separated. The default setting is the MAC address above.

DAD Transmit Count

Use this feature to set the number of consecutive neighbor solicitation messages have been sent while performing duplicate address detection on a tentative address. The default setting is **1**.

Policy

Use this feature to select how the policy is to be configured. The options are **automatic** and manual.

▶ Advanced Configuration

Note: This submenu is available when "Policy" is set to manual.

New IPv6 address: Use this feature to enter the IPv6 address for the local machine.

New Gateway addresses: Use this feature to set the gateway address for the local machine.

New DNS addresses: Use this feature to set the DNS server address for the local machine.

Commit Changes and Exit: Press <Enter> to save changes and exit.

Discard Changes and Exit: Press <Enter> to discard changes and exit.

Save Changes and Exit

Press <Enter> to save changes and exit.

PCH-FW Configuration

ME Firmware Version: 19.0.0.1797

ME Firmware Mode: Normal Mode

ME Firmware SKU: Corporate SKU

ME FW Image Re-Flash

Use this feature to update the Management Engine firmware. The options are **Disabled** and Enabled.

TPM Device Selection

Use this feature to select dTPM or PTT for the TPM device. dTPM is discrete Trusted Platform Module and PTT is Platform Trusted Technology. The options are **dTPM** and PTT.

AMT Configuration

USB Provisioning of AMT

Use this feature to enable or disable USB provisioning. The options are **Disabled** and Enabled.

MAC Pass Through

Use this feature to enable or disable the MAC Pass Through function. The options are **Disabled** and Enabled.

Activate Remote Assistance Process

Use this feature to activate Remote Assistance. Enabling this feature will also trigger the Client Initiated Remote Access (CIRA) boot. The options are **Disabled** and Enabled.

Unconfigure ME

Use this feature to unconfigure ME with resetting the MEBx password to default on next boot. The options are **Disabled** and Enabled.

ASF Configuration

PET Progress

Use this feature to enable or disable PET Events Progress to receive PET Events alerts. The options are Disabled and **Enabled**.

WatchDog

Select Enabled to allow AMT to reset or power down the system if the operating system or BIOS hangs or crashes. The options are **Disabled** and Enabled.

OS Timer / BIOS Timer

These options appear if WatchDog (above) is enabled. This is a timed delay in seconds, before a system power down or reset after a BIOS or operating system failure is detected. Enter the value in seconds. The default setting is **0**.

ASF Sensors Table

Enable this feature for the ASF Sensor Table to be added into the ASF ACPI table. The options are **Disabled** and Enabled.

Secure Erase Configuration

Secure Erase mode

Select Real to securely erase a solid state drive. The options are **Simulated** and Real.

Force Secure Erase

Select Enabled to force a secure erase of the solid state drive on the next boot. The options are **Disabled** and Enabled.

One Click Recovery (OCR) Configuration

OCR Https Boot

Use this feature to enable or disable One Click Recovery Https Boot. One Click Recovery is a recovery process that lets you restore your computer to its last known good state with a single command. The options are Disabled and **Enabled**.

OCR PBA Boot

Use this feature to enable or disable One Click Recovery PBA Boot. The options are Disabled and **Enabled**.

OCR Windows Recovery Boot

Use this feature to enable or disable One Click Recovery Windows Boot. The options are Disabled and **Enabled**.

OCR Disable Secure Boot

Use this feature to allow CSME to request Secure Boot to be disabled for One Click Recovery. The options are Disabled and **Enabled**.

PCIe/PCI/PnP Configuration Menu

PCI PERR/SERR Support

Use this feature to enable or disable the runtime event for PCI errors. The options are **Disabled** and Enabled.

Re-Size BAR Support

Use this feature to enable the Resizable BAR support. Resizable BAR is a PCIe interface technology that allows the CPU to access to the entire frame buffer. With this technology, your system will be able to handle multiple CPU to GPU transfers simultaneously rather than queuing, which can improve the frame rate performance. The options are **Disabled** and Enabled.

SR-IOV Support

Select Enabled for Single-Root IO Virtualization support. The options are **Disabled** and Enabled.

BME DMA Mitigation

Enable this feature to help block DMA attacks. The options are **Disabled** and Enabled.

Onboard Video Option ROM

Select EFI to boot the computer using the Extensible Firmware Interface (EFI) device installed on the onboard video port. The options are Disabled and **EFI**.

NVMe Firmware Source

Use this feature to select the NVMe firmware to support system boot. The options are **Vendor Defined Firmware** and AMI Native Support. The option of Vendor Defined Firmware is pre-installed on the drive and may resolve errata or enable innovative functions for the drive. The default option, AMI Native Support, is offered by the BIOS with a generic method.

Consistent Device Name Support

This feature controls the device naming for network devices and slots. The options are **Disabled** and Enabled.

Compatibility device Support

Select Enabled if Supermicro add-on card AOC-SLG3-2M2 is installed in SLOT3 of the motherboard. The options are **Disabled** and Enabled.

Note: This feature is for SLOT3 only, and do not select Enabled if AOC-SLG3-2M2 is not installed.

PCIe/PCI/PnP Configuration

CPU SLOT3 PCIe 5.0 x8 (IN X16) OPROM

CPU SLOT6 PCIe 5.0 x16 OPROM

CPU SLOT7 PCIe 4.0 x4 OPROM

M.2-C1 OPROM

M.2-P1 OPROM

SLIMSAS_8I Port0 OPROM

SLIMSAS_8I Port1 OPROM

Use this feature to select which firmware type to be loaded for the add-on card in this slot. The options are Disabled and **EFI**.

Onboard LAN1 Support

Use this feature to enable or disable LAN1. The options are Disabled and **Enabled**.

Onboard LAN2 Support

Use this feature to enable or disable LAN2. The options are Disabled and **Enabled**.

Onboard LAN1 Option ROM

Select EFI to boot the computer using the EFI device installed on LAN port 1. The options are Disabled and **EFI**.

Note: This feature is available when your motherboard supports onboard LAN ports.

SATA and RST Configuration

SATA And RST Configuration

SATA Controller(s)

Use this feature to enable or disable the onboard SATA controller supported by the Intel PCH chip. The options are **Enabled** and Disabled.

Support Aggressive Link Power Management

When this feature is set to Enabled, the SATA AHCI controller manages the power usage of the SATA link. The controller will put the link in a low power mode during extended periods of I/O inactivity and will return the link to an active state when I/O activity resumes. The options are Disabled and **Enabled**.

SATA0 / SATA1 / SATA2 / SATA3

This feature displays the information detected on the installed SATA drive on the particular SATA port.

Software Preserve Support

Hot Plug

Set this feature to Enable for hot plug support, which allows you to replace a SATA drive without shutting down the system. The options are Disabled and **Enabled**.

Spin Up Device

Set this feature to enable or disable the PCH to initialize the device. The options are **Disabled** and Enabled.

SATA Device Type

Use this feature to specify if the SATA port is connected to a Solid State Drive or a Hard Disk Drive. The options are **Hard Disk Drive** and Solid State Drive.

VMD Setup Menu

VMD Configuration

Enable VMD Controller

Use this feature to enable or disable the VMD controller. The options are **Disabled** and Enabled.

Enable VMD Global Mapping (Available when Enable VMD Controller is set to "Enabled")

Use this feature to enable or disable VMD global mapping. The options are **Disabled** and Enabled.

Map PCH SATA Controller under VMD (Available when Enable VMD Controller is set to "Enabled")

Use this feature to map or unmap the selected root port to VMD. The options are **Disabled** and Enabled.

Serial Port Console Redirection Menu

► Serial Port Console Redirection

COM1 (Available when your system supports the serial port of COM1)

Console Redirection

Select Enabled to enable COM port 1 for Console Redirection, which allows a client machine to be connected to a host machine at a remote site for networking. The options are **Disabled** and Enabled.

Note: This feature will be set to Enabled if there is no BMC support.

SOL/COM2

Note: This feature is available when your system supports serial port of SOL and/or COM2. The "SOL/COM2" here indicates a shared serial port, and SOL is used as the default.

Console Redirection

Select Enabled to use the SOL/COM2 port for Console Redirection. The options are Disabled and **Enabled**.

AMT SOL Console Redirection

Select Enabled to enable console redirection support for the specified serial port. The options are **Disabled** and Enabled.

► Console Redirection Settings

Note: This submenu is available when "Console Redirection" for COM1, SOL/COM2, or AMT SOL is set to Enabled.

Terminal Type

Use this feature to select the target terminal emulation type for Console Redirection. Select VT100 to use the ASCII Character set. Select VT100+ to add color and function key support. Select ANSI to use the Extended ASCII Character Set. Select VT-UTF8 to use UTF8 encoding to map Unicode characters into one or more bytes. The options are VT100, **VT100+**, VT-UTF8, and ANSI.

Bits Per Second

Use this feature to set the transmission speed for a serial port used in Console Redirection. Make sure that the same speed is used in the host computer and the client computer. A lower transmission speed may be required for long and busy lines. The options are 9600, 19200, 38400, 57600, and **115200** (bits per second).

Data Bits

Use this feature to set the data transmission size for Console Redirection. The options are 7 and **8** (bits).

Parity

A parity bit can be sent along with regular data bits to detect data transmission errors. Select Even if the parity bit is set to 0 and the number of 1s in data bits is even. Select Odd if the parity bit is set to 0 and the number of 1s in data bits is odd. Select None if you do not want to send a parity bit with your data bits in transmission. Select Mark to add a mark as a parity bit to be sent along with the data bits. Select Space to add a space as a parity bit to be sent with your data bits. The options are **None**, Even, Odd, Mark, and Space.

Stop Bits

A stop bit indicates the end of a serial data packet. Select 1 (stop bit) for standard serial data communication. Select 2 (stop bits) if slower devices are used. The options are **1** and 2.

Flow Control

Use this feature to set the flow control for Console Redirection to prevent data loss caused by buffer overflow. Send a "Stop" signal to stop sending data when the receiving buffer is full. Send a "Start" signal to start sending data when the receiving buffer is empty. The options are **None** and Hardware RTS/CTS.

VT-UTF8 Combo Key Support

Select Enabled to enable VT-UTF8 Combination Key support for ANSI/VT100 terminals. The options are Disabled and **Enabled**.

Recorder Mode

Select Enabled to capture the data displayed on a terminal and send it as text messages to a remote server. The options are **Disabled** and Enabled.

Resolution 100x31

Select Enabled for extended-terminal resolution support. The options are Disabled and **Enabled**.

Putty KeyPad

Use this feature to select function key and keypad settings on Putty, which is a terminal emulator designed for the Windows OS. The options are **VT100**, LINUX, XTERMR6, SCO, ESCN, and VT400.

Redirection After BIOS POST

Use this feature to enable or disable legacy console redirection after BIOS POST. When set to Bootloader, legacy console redirection is disabled before booting the OS. When set to Always Enable, legacy console redirection remains enabled when booting the OS. The options are **Always Enable** and Bootloader.

Serial Port for Out-of-Band Management/Windows Emergency Management Services (EMS)

Use the features below to configure Console Redirection settings to support Out-of-Band Serial Port management.

Console Redirection EMS

Select Enabled to use the SOL port for Console Redirection. The options are **Disabled** and Enabled.

► Console Redirection Settings

Note: This submenu is available when "Console Redirection EMS" is set to Enabled.

Out-of-Band Mgmt Port

The feature selects a serial port in a client server to be used by the Microsoft Windows Emergency Management Services (EMS) to communicate with a remote host server. The options are **COM1** and SOL/COM2. Please note that the option of SOL/COM2 indicates a shared serial port. SOL is available with BMC support.

Terminal Type EMS

Use this feature to select the target terminal emulation type for Console Redirection. Select VT100 to use the ASCII character set. Select VT100+ to add color and function key support. Select ANSI to use the extended ASCII character set. Select VT-UTF8 to use UTF8 encoding to map Unicode characters into one or more bytes. The options are VT100, VT100+, **VT-UTF8**, and ANSI.

Bits Per Second EMS

This feature sets the transmission speed for a serial port used in Console Redirection. Make sure that the same speed is used in the host computer and the client computer. A lower transmission speed may be required for long and busy lines. The options are 9600, 19200,

57600, and **115200** (bits per second).

Flow Control EMS

Use this feature to set the flow control for Console Redirection to prevent data loss caused by buffer overflow. Send a "Stop" signal to stop sending data when the receiving buffer is full. Send a "Start" signal to start sending data when the receiving buffer is empty. The options are **None**, Hardware RTS/CTS, and Software Xon/Xoff.

The following information is displayed.

- **Data Bits EMS**
- **Parity EMS**
- **Stop Bits EMS**

Trusted Computing Menu

► Trusted Computing

When the TPM 2.0 (either onboard or external) is detected by your system, the following information is displayed.

- TPM 2.0 Device Found
- Firmware Version:
- Vendor:

Note: This submenu is available when the TPM 2.0 (either onboard or external) is detected by the BIOS.

Security Device Support

Select Enabled to enable BIOS support for onboard security devices, which are not displayed in the OS. If this feature is set to Enabled, TCG EFI protocol and INT1A interface will not be available. The options are Disabled and **Enabled**.

When "Security Device Support" is set to Enabled and the TPM 2.0 (either onboard or external) is detected by the BIOS, the following information is displayed.

- Active PCR banks
- Available PCR banks

* The following features are available when the TPM 2.0 (either onboard or external) is detected by the BIOS.

SHA256 PCR Bank (Available when "Security Device Support" is set to Enabled)

Select Enabled to enable SHA256 PCR Bank support to enhance system integrity and data security. The options are Disabled and **Enabled**.

SHA384 PCR Bank (Available when "Security Device Support" is set to Enabled)

Select Enabled to enable SHA384 PCR Bank support to enhance system integrity and data security. The options are **Disabled** and Enabled.

Pending Operation (Available when "Security Device Support" is set to Enabled)

Use this feature to schedule a TPM-related operation to be performed by the security TPM (either onboard or external) at the next system boot to enhance system data integrity. The options are **None** and TPM Clear.

Note: If this feature is used, your system will reboot to carry out a pending TPM operation.

Platform Hierarchy (Available when "Security Device Support" is set to Enabled)

Select Enabled for TPM Platform Hierarchy support, which allows the manufacturer to utilize the cryptographic algorithm to define a constant key or a fixed set of keys to be used for initial system boot. These early boot codes are shipped with the platform and are included in the list of "public keys." During system boot, the platform firmware uses the trusted public keys to verify a digital signature in an attempt to manage and control the security of the platform firmware used in a host system via the TPM (either onboard or external). The options are Disabled and **Enabled**.

Storage Hierarchy (Available when "Security Device Support" is set to Enabled)

Select Enabled for TPM Storage Hierarchy support that is intended to be used for non-privacy-sensitive operations by a platform owner such as an IT professional or the end user. Storage Hierarchy has an owner policy and an authorization value, both of which can be set and are held constant (-rarely changed) through reboots. This hierarchy can be cleared or changed independently of the other hierarchies. The options are Disabled and **Enabled**.

Endorsement Hierarchy (Available when "Security Device Support" is set to Enabled)

Select Enabled for Endorsement Hierarchy support, which contains separate controls to address the user's privacy concerns because the primary keys in the hierarchy are certified by the TPM key or by a manufacturer with restrictions on how an authentic TPM (either onboard or external) that is attached to an authentic platform can be accessed and used. A primary key can be encrypted and certified with a certificate created by using TPM2_ActivateCredential, which allows the user to independently enable "flag, policy, and authorization values" without involving other hierarchies. A user with privacy concerns can disable the endorsement hierarchy while still using the storage hierarchy for TPM applications, permitting the platform software to use the TPM. The options are Disabled and **Enabled**.

TPM 2.0 InterfaceType (Available when "Security Device Support" is set to Enabled)

This feature displays the interface type of the detected TPM 2.0 module.

PH Randomization

Select Enabled for Platform Hierarchy (PH) Randomization support, which is used only during the platform developmental stage. This feature cannot be enabled in the production platforms. The options are **Disabled** and Enabled.

Intel Trusted Execution Technology

Intel Trusted Execution Technology (TXT) helps protect against software-based attacks and ensures protection, confidentiality, and integrity of data stored or created on the system. Use this feature to enable or disable TXT Support. The options are **Disabled** and Enabled.

USB Configuration

USB Configuration**USB Module Version****USB Controllers****USB Devices****XHCI Hand-off**

This is a work-around solution for operating systems that do not support Extensible Host Controller Interface (XHCI) hand-off. The XHCI ownership change should be claimed by the XHCI driver. The settings are **Enabled** and Disabled.

USB Mass Storage Driver Support

Select Enabled for USB mass storage device support. The options are Disabled and **Enabled**.

USB S5 Wakeup Support

Use this feature to enable or disable USB S5 Wakeup support. The options are Disabled and **Enabled**.

Intel(R) Ethernet Connection (19) I219-V - (MAC address) Menu

► Intel(R) Ethernet Connection (19) I219-V - (MAC address)

Autonegotiation Timeout

This features controls how long the UEFI PXE driver should wait for link. The default is **8**.

PORT CONFIGURATION INFORMATION

The following LAN port information will be displayed:

- UEFI Driver
- Adapter PBA
- PCI Device ID
- PCI Address
- MAC Address

Intel Ethernet Controller I226-LM - (MAC address) Menu

► Intel Ethernet Controller I226-LM - (MAC address)

The following LAN port information will be displayed:

- UEFI Driver
- PCI Device ID
- PCI Address
- MAC Address
- Link Status

Link auto-negotiation Timeout

This feature controls how long the UEFI PXE driver should wait for link. The default is **8**.

TLS Authenticate Configuration Menu

► TLS Authenticate Configuration

Use this submenu to configure Transport Layer Security (TLS) settings.

► Server CA Configuration

Use this feature to configure the client certificate that is to be used by the server.

► Enroll Certification

Use this feature to enroll the certificate in the system.

► Enroll Certification Using File

Use this feature to enroll the security certificate in the system by using a file.

Certification GUID

Press <Enter> and input the certification Global Unique Identifier (GUID).

▶ Commit Changes and Exit

Use this feature to save all changes and exit TLS settings.

▶ Discard Changes and Exit

Use this feature to discard all changes and exit TLS settings.

▶ Delete Certification

Use this feature to delete the certificate if a certificate has been enrolled in the system.

▶ Client Certification Configuration

Intel(R) Rapid Storage Technology Menu

Note: This submenu is available only when Advanced > VMD Setup Menu > "Enabled VMD controller" feature is set to Enabled and the changes have taken effect after you save settings and reboot the system.

Intel(R) RST xx.xx.xxxx RST VMD Driver

▶ Create RAID Volume

This submenu will only appear when VMD controller is enabled and the root port of the storage device for RAID array has been mapped under VMD. The mapped storage devices will appear in the Non-RAID Physical Disks list. For information on VMD configurations, please refer to the "VMD Setup Menu" feature.

Name

Enter a unique name for the RAID volume. The name must not contain space at the beginning or backslash and must be under 16 characters. The default is Volume1.

RAID Level

Select the desired RAID level for the RAID volume. The options are RAID0 (Stripe), RAID1 (Mirror), RAID5 (Parity), and RAID10 (RAID0+1). Available RAID levels depend on the number of disks connected to the system.

Select Disks

To select a desired RAID disk, select X from the drop-down list. Repeat this step to select all the desired disks for the RAID volume. For RAID0/RAID1/RAID5/RAID10, the minimum number of disks required is two/two/three/four respectively.

Strip Size (Available for RAID0/RAID5/RAID10 Only)

Select the desired RAID strip size for your RAID volume. The options vary according the RAID level you select.

Capacity (MB)

Enter the capacity in megabytes(MB) of the RAID volume to be created.

► Create Volume

After finishing the configuration of the Create RAID Volume feature, select Create Volume and you will return to the previous screen displaying the information about the created RAID volume.

RAID Volumes

This feature displays the RAID volumes you have created. You can click the created RAID volume to view more information.

RAID VOLUME INFO**Volume Actions****► Delete**

This feature allows you to delete a RAID volume. When asked to confirm deletion of the RAID volume, select Yes to delete the RAID volume.

Note: When deleting a RAID volume, all data on the disks will be deleted as well.

For a created RAID Volume, the following information will be displayed:

- Name
- RAID Level
- Strip Size
- Size
- Status
- Bootable

RAID Member Disks

This feature displays the RAID member disks.

Reset to non-RAID

This feature allows you to reset a RAID member disks to non-RAID disk. When asked to remove the RAID structure on the disk, select Yes to reset the disk.

Note: When resetting a disk, all data on the disk will be deleted as well.

Non-RAID Physical Disks

This feature lists the disks which have not been added to a RAID volume. Select a non-RAID physical disk and you can view the disk information.

Driver Health Menu

► Driver Health

This feature displays the health information of the drivers installed in your system, including LAN controllers, as detected by the BIOS. Select one and press <Enter> to see the details.

Note: This section is provided for reference only, for the driver health status will differ depending on the drivers installed in your system. It's also based on your system configuration and the environment that your system is operating in.

8.4 Event Logs

Use this menu to configure Event Logs settings.

Note: After making any changes in this section, please be sure to reboot the system for the changes to take effect.



Figure 8-3. Event Logs Screen

► Change SMBIOS Event Log Settings

Note: Reboot the system for the changes in this section to take effect.

Enabling/Disabling Options

SMBIOS Event Log

Select Enabled to enable System Management BIOS (SMBIOS) Event Logging during system boot. The options are Disabled and **Enabled**.

Erasing Settings

Erase Event Log (Available when "SMBIOS Event Log" is set to Enabled)

Select No to keep the event log without erasing it upon next system bootup. Select (Yes, Next reset) to erase the event log upon next system reboot. The options are **No**, (Yes, Next reset), and (Yes, Every reset).

When Log is Full (Available when "SMBIOS Event Log" is set to Enabled)

Select Erase Immediately to immediately erase all errors in the SMBIOS event log when the event log is full. Select Do Nothing for the system to do nothing when the SMBIOS event log is full. The options are **Do Nothing** and Erase Immediately.

SMBIOS Event Log Standard Settings

Log System Boot Event (Available when "SMBIOS Event Log" is set to Enabled)

Select Enabled to log system boot events. The options are Enabled and **Disabled**.

MECI (Available when "SMBIOS Event Log" is set to Enabled)

Enter the increment value for the multiple event counter. Enter a number between 1 and 255. The default setting is **1**. (MECI is the abbreviation for Multiple Event Count Increment.)

METW (Available when "SMBIOS Event Log" is set to Enabled)

Use this feature to determine how long (in minutes) should the multiple event counter wait before generating a new event log. Enter a number between 0 and 99. The default value is **60**. (METW is the abbreviation for Multiple Event Count Time Window.)

► View SMBIOS Event Log

Use this feature to view the event in the system event log. Select this feature and press <Enter> to view the status of an event in the log. The following information is displayed: DATE / TIME / ERROR CODE / SEVERITY.

8.5 Security

Use this menu to configure the following security settings for the system.

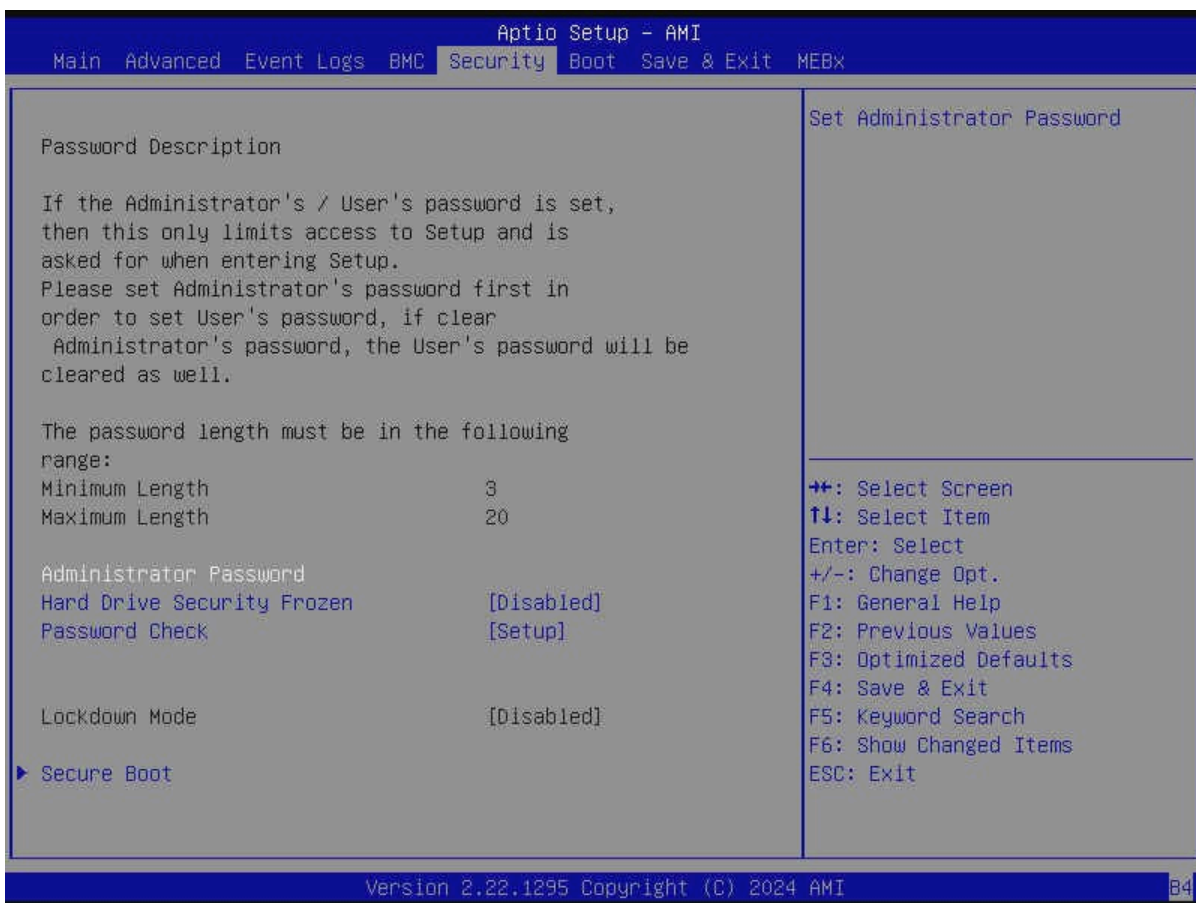

Figure 8-4. Security Screen

Disable Block Sid and Freeze Lock (Available when your storage devices support TCG)

Select Enabled to allow SID authentication to be performed in TCG storage devices. The options are **Disabled** and Enabled.

The following information is displayed:

- Administrator Password
- User Password
- Password Description

Administrator Password

This feature indicates if an administrator password has been installed. Use this feature to set the administrator password, which is required to enter the BIOS Setup utility. The length of the password can be between three and 20 characters long.

User Password (Available when "Administrator Password" has been set)

This feature indicates if a user password has been installed. Use this feature to set the user password which is required to enter the BIOS Setup utility. The length of the password can be between three and 20 characters long.

Password Check

Select Setup for the system to check for a password upon entering the BIOS Setup utility. Select Always for the system to check for the passwords needed at bootup and upon entering the BIOS Setup utility. The options are **Setup** and Always.

Hard Drive Security Frozen

Select Enabled to freeze the Lock Security feature for HDD to protect key data in hard drives from being altered. The options are **Disabled** and Enabled.

Lockdown Mode (Available when the DCMS key is activated)

Select Enabled to support the Lockdown Mode, which prevents the existing data or keys stored in the system from being altered or changed in an effort to preserve system integrity and security. The options are **Disabled** and Enabled.

Secure Boot Menu

► Secure Boot

The following information is displayed:

- System Mode
- Secure Boot

Note: For detailed instructions on configuring Security Boot settings, refer to the Security Boot Configuration User's Guide at <https://www.supermicro.com/support/manuals>.

Secure Boot

Select Enabled to configure Secure Boot settings. The options are **Disabled** and Enabled.

Secure Boot Mode

Use this feature to select the desired secure boot mode for the system. The options are Standard and **Custom**.

► Enter Audit Mode

Select Ok to enter the Audit Mode workflow. It will result in erasing the Platform Key (PK) variables and resetting the system to the Setup/Audit Mode.

Note: This submenu is available when "Secure Boot Mode" is set to Custom.

▶ Enter Deployed Mode / Exit Deployed Mode

Select Ok to reset system to the User Mode or to the Deployed Mode.

Note: This submenu is available when "Secure Boot Mode" is set to Custom.

▶ Key Management

The following information is displayed:

- Vendor Keys

Note: This submenu is available when "Secure Boot Mode" is set to Custom.

Provision Factory Defaults

Select Enabled to install provision factory default settings after a platform reset while the system is in the Setup Mode. The options are **Disabled** and Enabled.

▶ Restore Factory Keys

Select Yes to restore manufacturer default keys to ensure system security. The options are **Yes** and No. Selecting Yes will reset system to the User Mode.

Note: This submenu is available when any secure keys have been installed.

▶ Reset To Setup Mode

This feature resets the system to the Setup Mode. The options are **Yes** and No.

Note: This submenu is available when any secure keys have been installed.

▶ Enroll Efi Image

This feature allows the Efi image to run in the secure boot mode, which will enroll the SHA256 Hash certificate of a PE image into the Authorized Signature Database (DB).

▶ Export Secure Boot Variables

This feature exports the NVRAM contents of secure boot variables to a storage device. The options are **Yes** and No.

Note: This submenu is available when any secure keys have been installed.

Secure Boot variable / Size / Keys / Key Source

► Platform Key (PK)

Use this feature to enter and configure a set of values to be used as platform firmware keys for the system. These values also indicate the sizes, key numbers, and the sources of the authorized signatures. Select Update to update the platform key.

► Key Exchange Keys (KEK)

Use this feature to enter and configure a set of values to be used as Key Exchange Keys for the system. These values also indicate the sizes, key numbers, and the sources of the authorized signatures. Select Update to update the Key Exchange Keys. Select Append to append the Key Exchange Keys.

► Authorized Signatures (db)

Use this feature to enter and configure a set of values to be used as Authorized Signatures for the system. These values also indicate the sizes, key numbers, and sources of the authorized signatures. Select Update to update the Authorized Signatures. Select Append to append the new Authorized Signatures.

► Forbidden Signatures (dbx)

Use this feature to enter and configure a set of values to be used as Forbidden Signatures for the system. These values also indicate sizes, key numbers, and key sources of the forbidden signatures. Select Update to update the Forbidden Signatures. Select Append to append the Forbidden Signature.

► Authorized TimeStamps (dbt)

Use this feature to set and save the timestamps for the Authorized Signatures, which will indicate the time when these signatures are entered into the system. These values also indicate sizes, keys, and key sources of the authorized timestamps. Select Update to update the Authorized TimeStamps. Select Append to append the Authorized TimeStamps.

► OsRecovery Signatures (dbr)

Use this feature to set and save the Authorized Signatures used for OS recovery. Select Update to update the OsRecovery Signatures. These values also indicate sizes, keys, and key sources of the OsRecovery Signatures. Select Append to append the OsRecovery Signatures.

Supermicro Security Erase Configuration Menu

► Supermicro Security Erase Configuration

Use this submenu to configure the Supermicro-proprietary Security Erase settings. When this submenu is selected, the following information is displayed. Please note that the order of the following information may differ based on the storage devices being detected.

- HDD Name: This feature displays the model name of the storage device that is detected by the BIOS.
- HDD Serial Number: This feature displays the serial number of the storage device that is detected by the BIOS.
- Security Mode: This feature displays the security mode of the storage device that is detected by the BIOS.
- Estimated Time: This feature displays the estimate time needed to perform the selected Security Erase features.
- HDD User Pwd Status: This feature indicates if a password has been set as a storage device user password, which enables configuring Supermicro Security Erase settings on this storage device.
- TCG Device Type: This feature displays the TCG device type detected by the system.
- Admin Pwd Status: This feature indicates if a password has been set as a storage device administrator password, which enables configuring Supermicro Security Erase settings on this storage device.

Note: This submenu is available when any storage device is detected by the BIOS. For more information about this feature, refer to our website.

Security Function

Select Set Password to set a storage device password which enables configuring the security settings of the storage device. Select Security Erase - Password to enter a storage device user password to enable erasing the password and the contents previously stored in the storage device. Select Security Erase - Without Password to use the manufacturer default password

"1111111111" as the storage device user password and enable erasing the contents of the storage device by using this default password. The options are **Disabled**, Set Password, Change Password, Clear Password, Security Erase - Password, Security Erase - PSID, and Security Erase - Without Password.

Notes:

- The option of Security Erase - PSID is based on the storage device support. PSID is the abbreviation for Physical Security Identification.
- The options of Change Password and Clear Password are available when "Password" below has been set.
- The option of Set Password is not available when "Password" below has been set.

Password

Use this feature to set the storage device user password, which enables configuring the Supermicro Security Erase settings by using this user password.

New Password (Available when "Password" above has been set)

Use this feature to set the new user password for the storage device, which enables configuring the Supermicro Security Erase settings by using this new user password.

8.6 Boot

Use this menu to configure Boot settings.

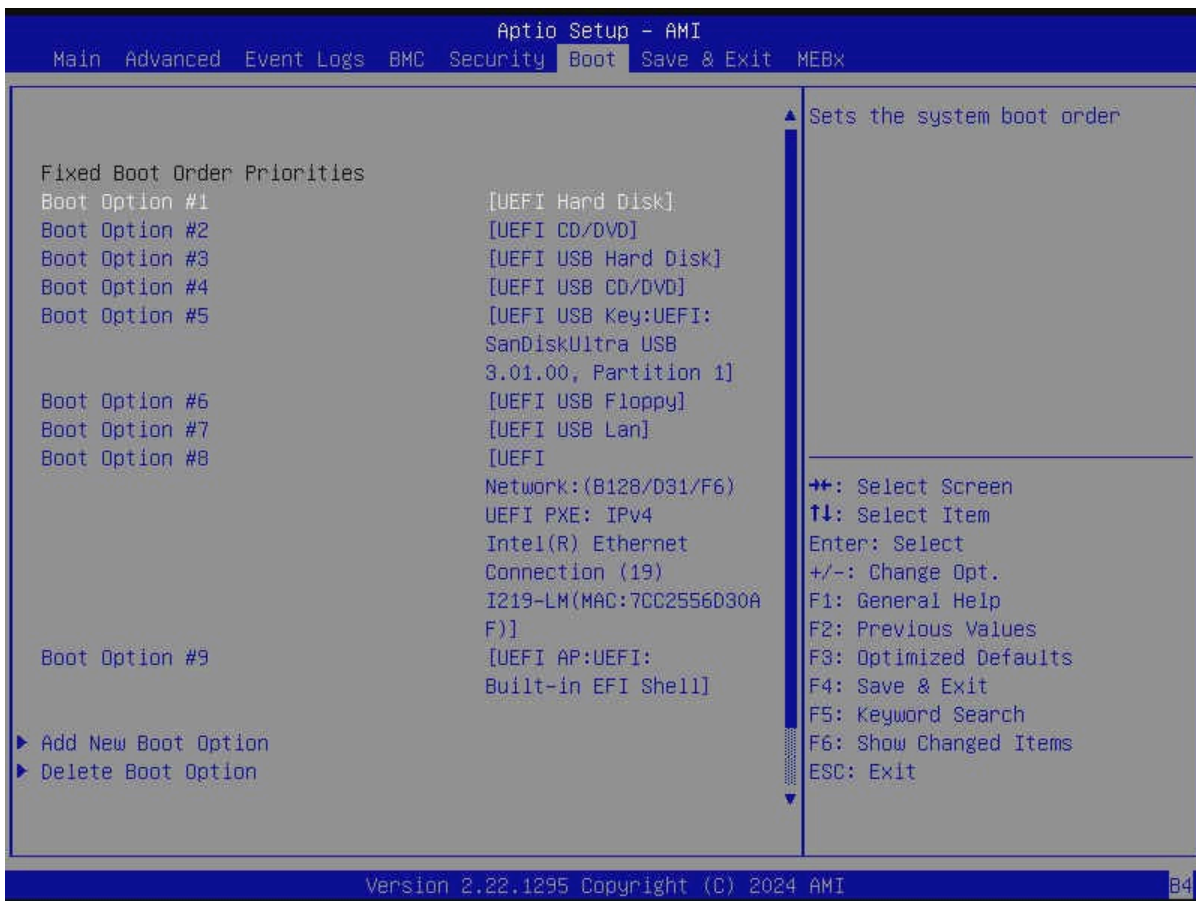

Figure 8-5. Boot Screen

FIXED BOOT ORDER Priorities

Use this feature to prioritize the order of a bootable device from which the system will boot. Press <Enter> on each item sequentially to select the device.

- Boot Option #1 – Boot Option #9

► Add New Boot Option

Use this feature to add a new boot option to the boot priority features for system boot.

Note: This submenu is available when any storage device is detected by the BIOS.

Add boot option

Use this feature to specify the name for the new boot option.

Path for boot option

Use this feature to enter the path for the new boot option in the format fsx:\path\filename.efi.

Boot option File Path

Use this feature to specify the file path for the new boot option.

Create

After setting the name and the file path for the boot option, press <Enter> to create the new boot option in the boot priority list.

▶ Delete Boot Option

Use this feature to select a boot device to delete from the boot priority list.

Delete Boot Option

Use this feature to remove an EFI boot option from the boot priority list.

▶ UEFI NETWORK Drive BBS Priorities

Use this feature to set the system boot order of detected devices.

▶ UEFI Application Boot Priorities

Use this feature to set the system boot order of detected devices.

▶ UEFI USB Key Drive BBS Priorities

Use this feature to set the system boot order of detected devices.

▶ UEFI Hard Disk Drive BBS Priorities

Use this feature to set the system boot order of detected devices.

8.7 Save & Exit

Select Save & Exit from the BIOS Setup screen to configure the settings below.

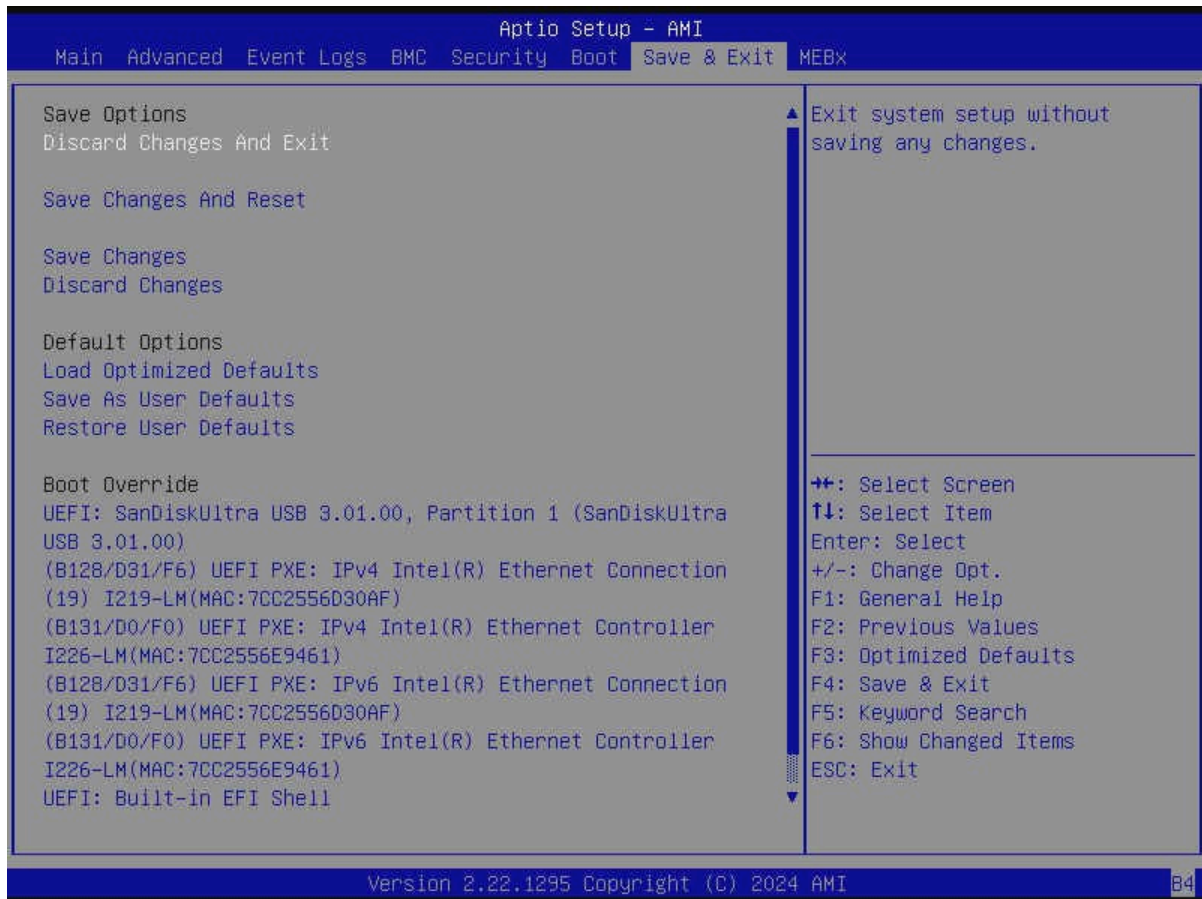

Figure 8-6. Save & Exit Screen

Save Options

Discard Changes and Exit

Use this feature to exit from the BIOS Setup utility without making any permanent changes to the system configuration and reboot the computer.

Save Changes and Reset

On completing the system configuration changes, use this feature to exit the BIOS Setup utility and reboot the computer for the new system configuration parameters to take effect.

Save Changes

On completing the system configuration changes, use this feature to save all changes made. This will not reset (reboot) the system.

Discard Changes

Select this feature and press <Enter> to discard all changes made and return to the BIOS Setup utility.

Default Options**Restore Optimized Defaults**

Select this feature and press <Enter> to load manufacturer optimized default settings, which are intended for maximum system performance but not for maximum stability.

Note: After pressing <Enter>, reboot the system for the changes to take effect, which ensures that this system has the optimized default settings.

Save As User Defaults

Select this feature and press <Enter> to save all changes as the default values specified to the BIOS Setup utility for future use.

Restore User Defaults

Select this feature and press <Enter> to retrieve user-defined default settings that have been saved previously.

Boot Override

Note: Use this section to override the Boot priorities sequence in the Boot menu, and immediately boot the system with a device specified here instead of the one specified in the boot list. This is a one-time boot override.

Launch EFI Shell from filesystem device

Use this feature to launch the EFI shell application (Shell.efi) from one of the available filesystem devices. A filesystem is a virtual, logical, or physical system for organizing, managing, and accessing the files and directories on devices such as SSDs, HDDs, or other storage devices.

8.8 MEBx

Select MEBx from the BIOS Setup screen to configure the settings below.

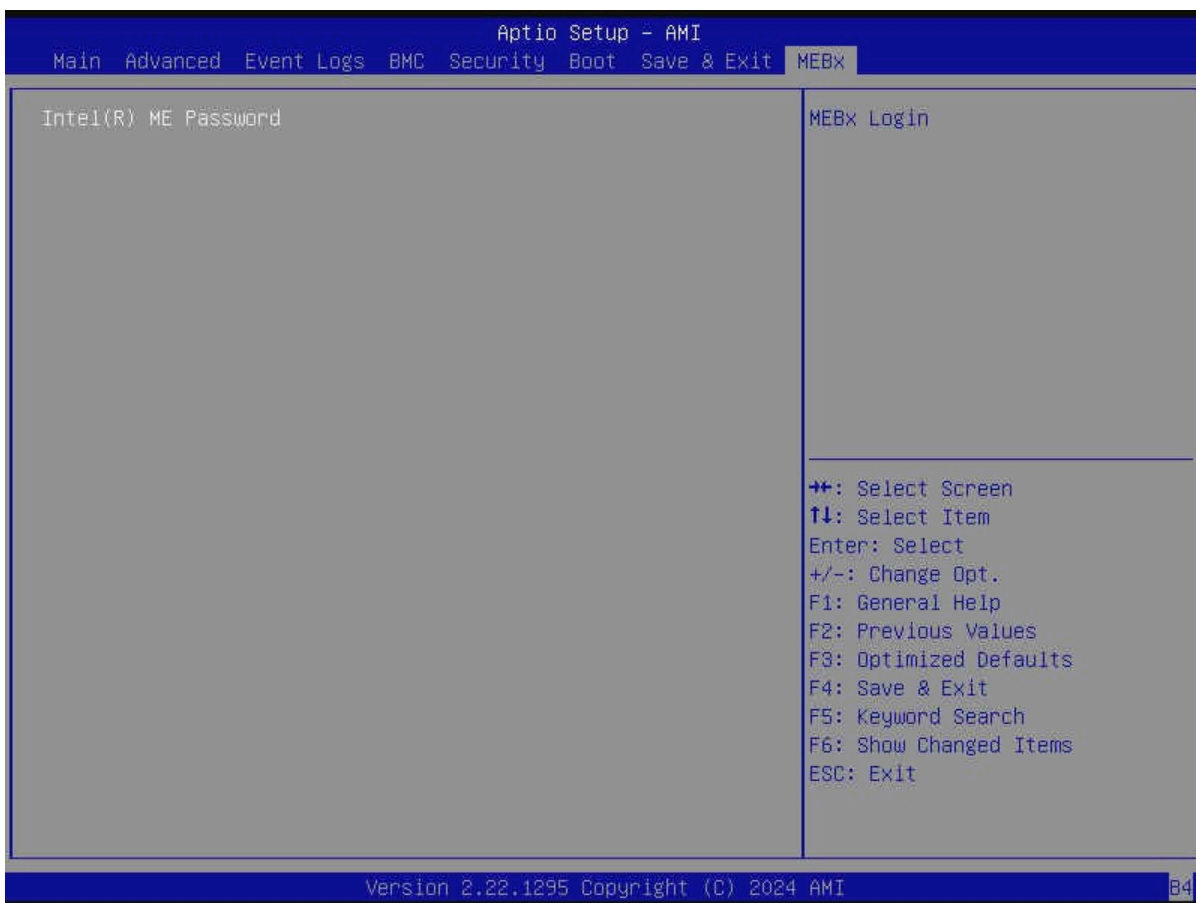

Figure 8-7. MEBx Screen

Intel(R) ME Password

Enter the password to bring up the Intel Management Engine (ME) setting menu. By default, the password is "admin" if you are the first time login. Intel ME will then prompt you to generate a new password. Please follow the guidelines below to set a new password.

- Password length must be between 8 and 32 characters.
- Must contain both upper and lower case letter.
- Must have at least one numeric character.
- Must have at least one ASCII non-alphanumeric character (!, @, #, \$, %, ^, &, *).

Appendix A:

BIOS Codes

For information about BIOS codes for the SYS-532AW-C workstation, refer to the following content.

BIOS Error POST (Beep) Codes

During the Power-On Self-Test (POST) routines, which are performed each time the system is powered on, errors may occur.

Non-fatal errors are those which, in most cases, allow the system to continue the boot up process. The error messages normally appear on the screen.

Fatal errors are those which will not allow the system to continue the boot up process. If a fatal error occurs, you should consult with your system manufacturer for possible repairs.

These fatal errors are usually communicated through a series of audible beeps that can be heard on an external buzzer connected to JD1. The table shown below lists some common errors and their corresponding beep codes encountered by users.

BIOS Beep (POST) Codes		
Beep Code	Error Message	Description
1 beep	Refresh	Circuits have been reset (Ready to power up)
5 short, 1 long	Memory error	No memory detected in system
5 short, 2 long	Display memory read/write error	Video adapter missing or with faulty memory
1 long continuous	System OH	System overheat condition

Additional BIOS POST Codes

The AMI BIOS supplies additional checkpoint codes, which are documented online at <https://www.supermicro.com/support/manuals> ("AMI BIOS POST Codes User's Guide").

For information on AMI updates, refer to <https://www.ami.com/products>.

Appendix B:

Standardized Warning Statements for AC Systems

The following statements are industry standard warnings, provided to warn the user of situations which have the potential for bodily injury. Should you have questions or experience difficulty, contact Supermicro's Technical Support department for assistance. Only certified technicians should attempt to install or configure components.

Read this section in its entirety before installing or configuring components in the Supermicro SYS-532AW-C workstation.

These warnings may also be found on our website at the following page:

https://www.supermicro.com/about/policies/safety_information.cfm

Warning Definition



Warning! This warning symbol means danger. You are in a situation that could cause bodily injury. Before you work on any equipment, be aware of the hazards involved with electrical circuitry and be familiar with standard practices for preventing accidents.

警告の定義

この警告サインは危険を意味します。

人身事故につながる可能性がありますので、いずれの機器でも動作させる前に、電気回路に含まれる危険性に注意して、標準的な事故防止策に精通して下さい。

此警告符号代表危險。

您正处于可能受到严重伤害的工作环境中。在您使用设备开始工作之前，必须充分意识到触电的危险，并熟练掌握防止事故发生的标准工作程序。请根据每项警告结尾的声明号码找到此设备的安全性警告说明的翻译文本。

此警告符號代表危險。

您正處於可能身體可能會受損傷的工作環境中。在您使用任何設備之前，請注意觸電的危險，並且要熟悉預防事故發生的標準工作程序。請依照每一注意事項後的號碼找到相關的翻譯說明內容。

Warnung

WICHTIGE SICHERHEITSHINWEISE

Dieses Warnsymbol bedeutet Gefahr. Sie befinden sich in einer Situation, die zu Verletzungen führen kann. Machen Sie sich vor der Arbeit mit Geräten mit den Gefahren elektrischer Schaltungen und den üblichen Verfahren zur Vorbeugung vor Unfällen vertraut. Suchen Sie mit der am Ende jeder Warnung angegebenen Anweisungsnummer nach der jeweiligen Übersetzung in den übersetzten Sicherheitshinweisen, die zusammen mit diesem Gerät ausgeliefert wurden.

BEWAHREN SIE DIESE HINWEISE GUT AUF.

INSTRUCCIONES IMPORTANTES DE SEGURIDAD

Este símbolo de aviso indica peligro. Existe riesgo para su integridad física. Antes de manipular cualquier equipo, considere los riesgos de la corriente eléctrica y familiarícese con los procedimientos estándar de prevención de accidentes. Al final de cada advertencia encontrará el número que le ayudará a encontrar el texto traducido en el apartado de traducciones que acompaña a este dispositivo.

GUARDE ESTAS INSTRUCCIONES.

IMPORTANTES INFORMATIONS DE SÉCURITÉ

Ce symbole d'avertissement indique un danger. Vous vous trouvez dans une situation pouvant entraîner des blessures ou des dommages corporels. Avant de travailler sur un équipement, soyez conscient des dangers liés aux circuits électriques et familiarisez-vous avec les procédures couramment utilisées pour éviter les accidents. Pour prendre connaissance des traductions des avertissements figurant dans les consignes de sécurité traduites qui accompagnent cet appareil, référez-vous au numéro de l'instruction situé à la fin de chaque avertissement.

CONSERVEZ CES INFORMATIONS.

תקנון הצהרות אזהרה

הצהרות הבאות הן אזהרות על פי תקני התעשייה, על מנת להזהיר את המשתמש מפני חבלה פיזית אפשרית. במידה ויש שאלות או היתקלות בבעיה כלשהי, יש ליצור קשר עם מחלקת תמיכה טכנית של סופרמיקרו. טכנאים מוסמכים בלבד רשאים להתקין או להגדיר את הרכיבים. יש לקרוא את הנספח במלואו לפני התקנת או הגדרת הרכיבים במארזי סופרמיקרו.

الكافة حالة وكي أي تتسبب ف اصابة جسده هذا الزهر ع خطر! تحذّر.

قبل أي تعول على أي هعدات، كي على علن بالوخاظر ال اجوة عي النوانز

الكهربائ ة

وكي على درا ة بالووارسات النقاء ة لو ع وقع أي حداثث

استخدم رقن الب إى الو صنص ف ها ة كل تحذّر للعنثر تزجوتها

안전을 위한 주의사항

경고!

이 경고 기호는 위험이 있음을 알려 줍니다. 작업자의 신체에 부상을 야기 할 수 있는 상태에 있게 됩니다. 모든 장비에 대한 작업을 수행하기 전에 전기회로와 관련된 위험요소들을 확인하시고 사전에 사고를 방지할 수 있도록 표준 작업절차를 준수해 주시기 바랍니다.

해당 번역문을 찾기 위해 각 경고의 마지막 부분에 제공된 경고문 번호를 참조하십시오

BELANGRIJKE VEILIGHEIDSINSTRUCTIES

Dit waarschuwings symbool betekent gevaar. U verkeert in een situatie die lichamelijk letsel kan veroorzaken. Voordat u aan enige apparatuur gaat werken, dient u zich bewust te zijn van de bij een elektrische installatie betrokken risico's en dient u op de hoogte te zijn van de standaard procedures om ongelukken te voorkomen. Gebruik de nummers aan het eind van elke waarschuwing om deze te herleiden naar de desbetreffende locatie.

BEWAAR DEZE INSTRUCTIES

Installation Instructions



Warning! Read the installation instructions before connecting the system to the power source.

設置手順書

システムを電源に接続する前に、設置手順書をお読み下さい。

警告

将此系统连接电源前,请先阅读安装说明。

警告

將系統與電源連接前,請先閱讀安裝說明。

Warnung

Vor dem Anschließen des Systems an die Stromquelle die Installationsanweisungen lesen.

¡Advertencia!

Lea las instrucciones de instalación antes de conectar el sistema a la red de alimentación.

Attention

Avant de brancher le système sur la source d'alimentation, consulter les directives d'installation.

יש לקרוא את הוראות התקנה לפני חיבור המערכת למקור מתח.

اقرأ إرشادات التركيب قبل توصيل النظام إلى مصدر للطاقة

시스템을 전원에 연결하기 전에 설치 안내를 읽어주십시오.

Waarschuwing

Raadpleeg de installatie-instructies voordat u het systeem op de voedingsbron aansluit.

Circuit Breaker



Warning! This product relies on the building's installation for short-circuit (overcurrent) protection. Ensure that the protective device is rated not greater than: 250 V, 20 A.

サーキット・ブレーカー

この製品は、短絡(過電流)保護装置がある建物での設置を前提としています。

保護装置の定格が250 V、20 Aを超えないことを確認下さい。

警告

此产品的短路(过载电流)保护由建筑物的供电系统提供,确保短路保护设备的额定电流不大于 250V,20A。

警告

此產品的短路(過載電流)保護由建築物的供電系統提供,確保短路保護設備的額定電流不大於 250V,20A。

Warnung

Dieses Produkt ist darauf angewiesen, dass im Gebäude ein Kurzschluss- bzw. Überstromschutz installiert ist. Stellen Sie sicher, dass der Nennwert der Schutzvorrichtung nicht mehr als: 250 V, 20 A beträgt.

¡Advertencia!

Este equipo utiliza el sistema de protección contra cortocircuitos (o sobrecorrientes) del edificio. Asegúrese de que el dispositivo de protección no sea superior a: 250 V, 20 A.

Attention

Pour ce qui est de la protection contre les courts-circuits (surtension), ce produit dépend de l'installation électrique du local. Vérifiez que le courant nominal du dispositif de protection n'est pas supérieur à :250 V, 20 A.

מוצר זה מסתמך על הגנה המותקנת במבנים למניעת קצר חשמלי. יש לוודא כי

המכשיר המגן מפני הקצר החשמלי הוא לא יותר מ-250V, 20A

هذا المنتج يعتمد على معدات الحماية من الدوائر القصيرة التي تم تثبيتها في
المبنى

تأكد من أن تقييم الجهاز الوقائي ليس أكثر من : 20A, 250V

경고!

이 제품은 전원의 단락(과전류)방지에 대해서 전적으로 건물의 관련 설비에 의존합니다. 보호장치의 정격이 반드시 250V(볼트), 20A(암페어)를 초과하지 않도록 해야 합니다.

Waarschuwing

Dit product is afhankelijk van de kortsluitbeveiliging (overspanning) van uw elektrische installatie. Controleer of het beveiligde apparaat niet groter gedimensioneerd is dan 250V, 20A.

Power Disconnection Warning



Warning! The system must be disconnected from all sources of power and the power cord removed from the power supply module(s) before accessing the chassis interior to install or remove system components (except for hot-swap components).

電源切断の警告

システムコンポーネントの取り付けまたは取り外しのために、シャーシ内部にアクセスするには、システムの電源はすべてのソースから切断され、電源コードは電源モジュールから取り外す必要があります。

警告

在你打开机箱并安装或移除内部器件前,必须将系统完全断电,并移除电源线。

警告

在您打開機殼安裝或移除內部元件前,必須將系統完全斷電,並移除電源線。

Warnung

Das System muss von allen Quellen der Energie und vom Netzanschlusskabel getrennt sein, das von den Spg.Versorgungsteilmodulen entfernt wird, bevor es auf den Chassisinnenraum zurückgreift, um Systemsbestandteile anzubringen oder zu entfernen.

¡Advertencia!

El sistema debe ser disconnected de todas las fuentes de energía y del cable eléctrico quitado de los módulos de fuente de alimentación antes de tener acceso el interior del chasis para instalar o para quitar componentes de sistema.

Attention

Le système doit être débranché de toutes les sources de puissance ainsi que de son cordon d'alimentation secteur avant d'accéder à l'intérieur du châssis pour installer ou enlever des composants de système.

אזהרה מפני ניתוק חשמלי

אזהרה!

יש לנתק את המערכת מכל מקורות החשמל ויש להסיר את כבל החשמלי מהספק לפני גישה לחלק הפנימי של המארז לצורך התקנת או הסרת רכיבים.

يجب فصل انظماو من جميع مصادر انطاقت وإزانت سهك انكهرباء من وحدة امداد انطاقت قيم

انصلل إلى انمناطق انداخييت نههيكم ننتبيج أو إزانت مكنناث الجهاز

경고!

시스템에 부품들을 장착하거나 제거하기 위해서는 새시 내부에 접근하기 전에 반드시 전원 공급장치로부터 연결되어있는 모든 전원과 전기코드를 분리해주어야 합니다.

Waarschuwing

Voordat u toegang neemt tot het binnenwerk van de behuizing voor het installeren of verwijderen van systeem onderdelen, dient u alle spanningsbronnen en alle stroomkabels aangesloten op de voeding(en) van de behuizing te verwijderen

Equipment Installation



Warning! Only authorized personnel and qualified service persons should be allowed to install, replace, or service this equipment.

機器の設置

トレーニングを受け認定された人だけがこの装置の設置、交換、またはサービスを許可されています。

警告

只有经过培训且具有资格的人员才能进行此设备的安装、更换和维修。

警告

只有經過受訓且具資格人員才可安裝、更換與維修此設備。

Warnung

Nur autorisiertes Personal und qualifizierte Servicetechniker dürfen dieses Gerät installieren, austauschen oder warten.

¡Advertencia!

Sólo el personal autorizado y el personal de servicio calificado deben poder instalar, reemplazar o dar servicio a este equipo.

Attention

Seul le personnel autorisé et le personnel de maintenance qualifié doivent être autorisés à installer, remplacer ou entretenir cet équipement.

אזהרה!

יש לאפשר רק צוות מורשה ואנשי שירות מוסמכים להתקין, להחליף או לטפל בצידוד זה

ينبغي السماح فقط للموظفين المعتمدين وأفراد الخدمة المؤهلين بتركيب هذا الجهاز أو استبداله أو صيانته

경고!

승인된 직원과 자격을 갖춘 서비스 담당자만이 이 장비를 설치, 교체 또는 서비스할 수 있습니다.

Waarschuwing

Alleen geautoriseerd personeel en gekwalificeerd onderhoudspersoneel mag deze apparatuur installeren, vervangen of onderhouden.

Restricted Area



Warning! This unit is intended for installation in restricted access areas. A restricted access area can be accessed only through the use of a special tool, lock and key, or other means of security. (This warning does not apply to workstations).

アクセス制限区域

このユニットは、アクセス制限区域に設置されることを想定しています。

アクセス制限区域は、特別なツール、鍵と錠前、その他のセキュリティの手段を用いてのみ出入りが可能です。

警告

此部件应安装在限制进出的场所，限制进出的场所指只能通过使用特殊工具、锁和钥匙或其它安全手段进出的场所。

警告

此装置僅限安裝於進出管制區域，進出管制區域係指僅能以特殊工具、鎖頭及鑰匙或其他安全方式才能進入的區域。

Warnung

Diese Einheit ist zur Installation in Bereichen mit beschränktem Zutritt vorgesehen. Der Zutritt zu derartigen Bereichen ist nur mit einem Spezialwerkzeug, Schloss und Schlüssel oder einer sonstigen Sicherheitsvorkehrung möglich.

¡Advertencia!

Esta unidad ha sido diseñada para instalación en áreas de acceso restringido. Sólo puede obtenerse acceso a una de estas áreas mediante la utilización de una herramienta especial, cerradura con llave u otro medio de seguridad.

Attention

Cet appareil doit être installée dans des zones d'accès réservés. L'accès à une zone d'accès réservé n'est possible qu'en utilisant un outil spécial, un mécanisme de verrouillage et une clé, ou tout autre moyen de sécurité.

אזור עם גישה מוגבלת

אזהרה!

יש להתקין את היחידה באזורים שיש בהם הגבלת גישה. הגישה ניתנת בעזרת כלי אבטחה בלבד (מפתח, מנעול וכד.).

اتخصيص هذه انحدة نترك بها ف مناطق محظورة تم .

ممكن انصلل إن منطقت محظورة فقط من خلال استخدام أداة خاصت،

أو أوس هُت أخري نلاأما ققم ومفتاح

경고!

이 장치는 접근이 제한된 구역에 설치하도록 되어있습니다. 특수도구, 잠금 장치 및 키, 또는 기타 보안 수단을 통해서만 접근 제한 구역에 들어갈 수 있습니다.

Waarschuwing

Dit apparaat is bedoeld voor installatie in gebieden met een beperkte toegang. Toegang tot dergelijke gebieden kunnen alleen verkregen worden door gebruik te maken van speciaal gereedschap, slot en sleutel of andere veiligheidsmaatregelen.

Battery Handling



CAUTION There is risk of explosion if the battery is replaced by an incorrect type. Replace the battery only with the same or equivalent type recommended by the manufacturer. Dispose of used batteries according to the manufacturer's instructions.

電池の取り扱い

バッテリーを間違ったタイプに交換すると爆発の危険があります。交換する電池はメーカーが推奨する型、または同等のものを使用下さい。使用済電池は製造元の指示に従って処分して下さい。

警告

如果更换的电池类型不正确。请只使用同类电池或制造商推荐的功能相当的电池更换原有电池。请按制造商的说明处理废旧电池。

警告

如果更換的電池類型不正確。請使用製造商建議之相同或功能相當的電池更換原有電池。請按照製造商的說明指示處理廢棄舊電池。

WARNUNG

Es besteht Explosionsgefahr, wenn die Batterie durch einen falschen Typ ersetzt wird. Ersetzen Sie die Batterie nur durch den gleichen oder vom Hersteller empfohlenen Batterietyp. Entsorgen Sie die benutzten Batterien nach den Anweisungen des Herstellers.

ADVERTENCIA

Existe riesgo de explosión si la batería se reemplaza por un tipo incorrecto. Reemplazar la batería exclusivamente con el mismo tipo o el equivalente recomendado por el fabricante. Desechar las baterías gastadas según las instrucciones del fabricante.

ATTENTION

Il existe un risque d'explosion si la batterie est remplacée par un type incorrect. Ne la remplacer que par une pile de type semblable ou équivalent, recommandée par le fabricant. Jeter les piles usagées conformément aux instructions du fabricant.

אזהרה!

קיימת סכנת פיצוץ אם הסוללה תוחלף בסוג שגוי. יש להחליף את הסוללה בסוג התואם מחברת יצרן מומלצת. סילוק הסוללות המשומשות יש לבצע לפי הוראות היצרן.

هناك خطر الانفجار إذا تم استبدال البطارية بنوع غير صحيح

استبدال البطارية

فقط بنفس النوع أو ما يعادلها مما أوصت به الشركة المصنعة

جخلص من البطاريات المسحمة وفقاً لتعليمات الشركة الصانعة

경고!

배터리를 잘못된 종류로 교체하면 폭발의 위험이 있습니다. 기존 배터리와 동일하거나 제조사에서 권장하는 동등한 종류의 배터리로만 교체해야 합니다. 제조사의 안내에 따라 사용된 배터리를 처리하여 주십시오.

WAARSCHUWING

Er bestaat explosiegevaar als de batterij wordt vervangen door een verkeerd type. Vervang de batterij slechts met hetzelfde of een equivalent type die door de fabrikant aanbevolen wordt. Gebruikte batterijen dienen overeenkomstig fabrieksvoorschriften afgevoerd te worden.

Redundant Power Supplies

Warning! This unit might have more than one power supply connection. All connections must be removed to de-energize the unit.

冗長電源装置

このユニットは複数の電源装置が接続されている場合があります。

ユニットの電源を切るためには、すべての接続を取り外さなければなりません。

警告

此部件连接的电源可能不止一个，必须将所有电源断开才能停止给该部件供电。

警告

此装置连接的电源可能不只一个，必须切断所有电源才能停止对该装置的供电。

Warnung

Dieses Gerät kann mehr als eine Stromzufuhr haben. Um sicherzustellen, dass der Einheit kein Strom zugeführt wird, müssen alle Verbindungen entfernt werden.

¡Advertencia!

Puede que esta unidad tenga más de una conexión para fuentes de alimentación. Para cortar por completo el suministro de energía, deben desconectarse todas las conexiones.

Attention

Cette unité peut avoir plus d'une connexion d'alimentation. Pour supprimer toute tension et tout courant électrique de l'unité, toutes les connexions d'alimentation doivent être débranchées.

אם קיים יותר מספק אחד

אזהרה!

ליחידה יש יותר מחיבור אחד של ספק. יש להסיר את כל החיבורים על מנת לרוקן

את היחידה.

قد يكون لهذا الجهاز عدة اتصالات بوحدات امداد الطاقة .

يجب إزالة كافة الاتصالات لعزل الوحدة عن الكهرباء

경고!

이 장치에는 한 개 이상의 전원 공급 단자가 연결되어 있을 수 있습니다. 이 장치에 전원을 차단하기 위해서는 모든 연결 단자를 제거해야만 합니다.

Waarschuwing

Deze eenheid kan meer dan één stroomtoevoeraansluiting bevatten. Alle aansluitingen dienen verwijderd te worden om het apparaat stroomloos te maken.

Backplane Voltage



Warning! Hazardous voltage or energy is present on the backplane when the system is operating. Use caution when servicing.

バックプレーンの電圧

システムの稼働中は危険な電圧または電力が、バックプレーン上にかかっています。

修理する際には注意ください。

警告

当系统正在进行时，背板上有很危险的电压或能量，进行维修时务必小心。

警告

當系統正在進行時，背板上有危險的電壓或能量，進行維修時務必小心。

Warnung

Wenn das System in Betrieb ist, treten auf der Rückwandplatine gefährliche Spannungen oder Energien auf. Vorsicht bei der Wartung.

¡Advertencia!

Cuando el sistema está en funcionamiento, el voltaje del plano trasero es peligroso. Tenga cuidado cuando lo revise.

Attention

Lorsque le système est en fonctionnement, des tensions électriques circulent sur le fond de panier. Prendre des précautions lors de la maintenance.

מתח בפנל האחורי

אזהרה!

קיימת סכנת מתח בפנל האחורי בזמן תפעול המערכת. יש להיזהר במהלך

העבודה.

هناك خطر من التيار الكهربائي أو الطاقة المخزنة على اللوحة

عندما يكون النظام يعمل كه حذرا عند خدمة هذا الجهاز

경고!

시스템이 동작 중일 때 후면판 (Backplane)에는 위험한 전압이나 에너지가 발생 합니다. 서비스 작업 시 주의하십시오.

Waarschuwing

Een gevaarlijke spanning of energie is aanwezig op de backplane wanneer het systeem in gebruik is. Voorzichtigheid is geboden tijdens het onderhoud.

Comply with Local and National Electrical Codes



Warning! Installation of the equipment must comply with local and national electrical codes.

地方および国の電気規格に準拠

機器の取り付けはその地方および国の電気規格に準拠する必要があります。

警告

设备安装必须符合本地与本国电气法规。

警告

設備安裝必須符合本地與本國電氣法規。

Warnung

Die Installation der Geräte muss den Sicherheitsstandards entsprechen.

¡Advertencia!

La instalacion del equipo debe cumplir con las normas de electricidad locales y nacionales.

Attention

L'équipement doit être installé conformément aux normes électriques nationales et locales.

תיאום חוקי החשמל הארצי

אזהרה!

התקנת הציוד חייבת להיות תואמת לחוקי החשמל המקומיים והארציים.

تركيب المعدات الكهربائية يجب أن يمتثل للقوانين المحلية والنظمية المتعلقة

بالكهرباء

경고!

현 지역 및 국가의 전기 규정에 따라 장비를 설치해야 합니다.

Waarschuwing

Bij installatie van de apparatuur moet worden voldaan aan de lokale en nationale elektriciteitsvoorschriften.

Product Disposal



Warning! Ultimate disposal of this product should be handled according to all national laws and regulations.

製品の廃棄

この製品を廃棄処分する場合、国の関係する全ての法律・条例に従い処理する必要があります。

警告

本产品的废弃处理应根据所有国家的法律和规章进行。

警告

本產品的廢棄處理應根據所有國家的法律和規章進行。

Warnung

Die Entsorgung dieses Produkts sollte gemäß allen Bestimmungen und Gesetzen des Landes erfolgen.

¡Advertencia!

Al deshacerse por completo de este producto debe seguir todas las leyes y reglamentos nacionales.

Attention

La mise au rebut ou le recyclage de ce produit sont généralement soumis à des lois et/ou directives de respect de l'environnement. Renseignez-vous auprès de l'organisme compétent.

סילוק המוצר

אזהרה!

סילוק סופי של מוצר זה חייב להיות בהתאם להנחיות וחוקי המדינה.

عند التخلص النهائي من هذا المنتج ينبغي التعامل معه وفقا لجميع القوانين واللوائح الوطنية

경고!

이 제품은 해당 국가의 관련 법규 및 규정에 따라 폐기되어야 합니다.

Waarschuwing

De uiteindelijke verwijdering van dit product dient te geschieden in overeenstemming met alle nationale wetten en reglementen.

Fan Warning



Warning! Hazardous moving parts. Keep away from moving fan blades. The fans might still be turning when you remove the fan assembly from the chassis. Keep fingers, screwdrivers, and other objects away from the openings in the fan assembly's housing



ファンの警告

警告！ 回転部品に注意。運転中は回転部(羽根)に触れないでください。シャーシから冷却ファン装置を取り外した際、ファンがまだ回転している可能性があります。ファンの開口部に、指、ドライバー、およびその他のものを近づけないで下さい。

警告!

警告! 危险的可移动性零件。请务必与转动的风扇叶片保持距离。当您从机架移除风扇装置, 风扇可能仍在转动。小心不要将手指、螺丝起子和其他物品太靠近风扇

警告

危險的可移動性零件。請務必與轉動的風扇葉片保持距離。當您從機架移除風扇裝置, 風扇可能仍在轉動。小心不要將手指、螺絲起子和其他物品太靠近風扇。

Warnung

Gefährlich Bewegende Teile. Von den bewegenden Lüfterblätter fern halten. Die Lüfter drehen sich u. U. noch, wenn die Lüfterbaugruppe aus dem Chassis genommen wird. Halten Sie Finger, Schraubendreher und andere Gegenstände von den Öffnungen des Lüftergehäuses entfernt.

¡Advertencia!

Riesgo de piezas móviles. Mantener alejado de las aspas del ventilador. Los ventiladores podran dar vuelta cuando usted quite el montaje del ventilador del chasis. Mantenga los dedos, los destornilladores y todos los objetos lejos de las aberturas del ventilador.

Attention

Pieces mobiles dangereuses. Se tenir a l'écart des lames du ventilateur Il est possible que les ventilateurs soient toujours en rotation lorsque vous retirerez le bloc ventilateur du châssis. Prenez garde à ce que doigts, tournevis et autres objets soient éloignés du logement du bloc ventilateur.

אזהרה!

חלקים נעים מסוכנים. התרחק מלהבי המאוורר בפעולהכאשר מסירים את חלקי המאוורר מהמארז, יתכן והמאווררים עדיין עובדים. יש להרחיק למרחק בטוח את האצבעות וכלי עבודה שונים מהפתחים בתוך המאוורר

تحذير! أجزاء متحركة خطيرة. ابتعد عن شفرات المروحة المتحركة. من الممكن أن المراوح لا تزال تدور عند إزالة كتلة المروحة من الهيكل يجب إبقاء الأصابع ومفكات البراغي وغيرها من الأشياء بعيدا عن الفتحات في كتلة المروحة.

경고!

움직이는 위험한 부품. 회전하는 송풍 날개에 접근하지 마세요. 새시로부터 팬 조립품을 제거할 때 팬은 여전히 회전하고 있을 수 있습니다. 팬 조립품 외관의 열려있는 부분들로부터 손가락 및 스크류드라이버, 다른 물체들이 가까이 하지 않도록 배치해 주십시오.

Waarschuwing

Gevaarlijk bewegende onderdelen. Houd voldoende afstand tot de bewegende ventilatorbladen. Het is mogelijk dat de ventilator nog draait tijdens het verwijderen van het ventilatorsamenstel uit het chassis. Houd uw vingers, schroevendraaiers en eventuele andere voorwerpen uit de buurt van de openingen in de ventilatorbehuizing.

Power Cable and AC Adapter



Warning! When installing the product, use the provided or designated connection cables, power cables and AC adaptors. Using any other cables and adaptors could cause a malfunction or a fire. Electrical Appliance and Material Safety Law prohibits the use of UL or CSA -certified cables (that have UL/CSA shown on the cord) for any other electrical devices than products designated by Supermicro only.

電源コードとACアダプター

製品を設置する場合、提供または指定および購入された接続ケーブル、電源コードとACアダプターを該当する地域の条例や安全基準に適合するコードサイズやプラグと共に使用下さい。他のケーブルやアダプタを使用すると故障や火災の原因になることがあります。

電気用品安全法は、ULまたはCSA認定のケーブル(UL/CSAマークがコードに表記)をSupermicroが指定する製品以外に使用することを禁止しています。

警告

安裝此產品時,請使用本身提供的或指定的或採購的連接線,電源線和電源適配器,包含遵照當地法規和安全要求的合規的電源線尺寸和插頭.使用其它線材或適配器可能會引起故障或火災。除了 Supermicro 所指定的產品,電氣用品和材料安全法律規定禁止使用未經 UL 或 CSA 認證的線材。(線材上會顯示 UL/CSA 符號)。

警告

安裝此產品時,請使用本身提供的或指定的或採購的連接線,電源線和電源適配器,包含遵照當地法規和安全要求的合規的電源線尺寸和插頭.使用其它線材或適配器可能會引起故障或火災。除了 Supermicro 所指定的產品,電氣用品和材料安全法律規定禁止使用未經 UL 或 CSA 認證的線材。(線材上會顯示 UL/CSA 符號)。

Warnung

Nutzen Sie beim Installieren des Produkts ausschließlich die von uns zur Verfügung gestellten Verbindungskabeln, Stromkabeln und/oder Adapter, die Ihre örtlichen Sicherheitsstandards einhalten. Der Gebrauch von anderen Kabeln und Adapter können Fehlfunktionen oder Feuer verursachen. Die Richtlinien untersagen das Nutzen von UL oder CAS zertifizierten Kabeln (mit UL/CSA gekennzeichnet), an Geräten oder Produkten die nicht mit Supermicro gekennzeichnet sind.

¡Advertencia!

Cuando instale el producto, utilice la conexión provista o designada o procure cables, Cables de alimentación y adaptadores de CA que cumplan con los códigos locales y los requisitos de seguridad, incluyendo el tamaño adecuado del cable y el enchufe. El uso de otros cables y adaptadores podría causar un mal funcionamiento o un incendio. La Ley de Seguridad de Aparatos Eléctricos y de Materiales prohíbe El uso de cables certificados por UL o CSA (que tienen el certificado UL / CSA en el código) para cualquier otros dispositivos eléctricos que los productos designados únicamente por Supermicro.

Attention

Lors de l'installation du produit, utilisez les câbles de connexion fournis ou désigné ou achetez des câbles, câbles de puissance et adaptateurs respectant les normes locales et les conditions de sécurité y compris les tailles de câbles et les prises électriques appropriées. L'utilisation d'autres câbles et adaptateurs peut provoquer un dysfonctionnement ou un incendie. Appareils électroménagers et la Loi sur la Sécurité Matériel interdit l'utilisation de câbles certifiés- UL ou CSA (qui ont UL ou CSA indiqué sur le code) pour tous les autres appareils électriques sauf les produits désignés par Supermicro seulement.

AC ימאתמו םיילמשח םילבכ

הרהזא!

ךרוצל ומאתוה וא ושכרנ רשא AC םימאתמו םיקפס, םילבכב שמתשהל שי, רצומה תא םיניקתמ רשאכ לכב שומיש . עקתהו לבכה לש הנוכנ הדימ ללוכ, תוימוקמה תוחיטבה תושירדל ומאתוה רשאו, הנקתהה למשחה ירישכמב שומישה יקוחל סאתהב . ילמשח רצק וא הלקתל םורגל לולע, רחא גוסמ סאתמ וא לבכ לש דוק םהילע עיפומ רשאכ) CSA- ב וא UL - ב םיכסומה םילבכב שמתשהל רוסיא םייק, תוחיטבה יקוחו דבלב Supermicro י"ע סאתוה רשא רצומב קר אלא, רחא ילמשח רצומ לכ רובע (UL/CSA).

תאלבאקלא ׁארשב مق وأ ءددمحلا وأ ءرفوتملا تاليصوتلا مادختساب مق ،جتتملا بيكرت دنع

كلذ يف امب ءيلحملا ءمالسلا تابلطتمو نيناوقب ماز تلالا عم ددرتملا رايتلا تالوحمو ءيناوبرهكلا

قيرح وأ لطح يف ببستي دق برخأ تالوحمو تالباك يا مادختسا .ميلسلا سباقلاو لصوملا مجح .

CSA وأ UL لبق نم ءدمتعملا تالباكلا مادختسا تادعملاو ءيناوبرهكلا ءز هجالل ءمالسلا نوناق رظحي

Supermicro لبق نم ءددمحلاو ءينعملا تاجتملا ريغ برخأ تادعم يا عم (UL/CSA) ءمالع لمحت يتلاو .

전원 케이블 및 AC 어댑터

경고! 제품을 설치할 때 현지 코드 및 적절한 굵기의 코드와 플러그를 포함한 안전 요구 사항을 준수하여 제공되거나 지정된 연결 혹은 구매 케이블, 전원 케이블 및 AC 어댑터를 사용하십시오.

다른 케이블이나 어댑터를 사용하면 오작동이나 화재가 발생할 수 있습니다. 전기 용품 안전법은 UL 또는 CSA 인증 케이블 (코드에 UL / CSA가 표시된 케이블)을 Supermicro 가 지정한 제품 이외의 전기 장치에 사용하는 것을 금지합니다.

Stroomkabel en AC-Adapter

Waarschuwing! Bij het aansluiten van het Product uitsluitend gebruik maken van de geleverde Kabels of een andere geschikte aan te schaffen Aansluitmethode, deze moet altijd voldoen aan de lokale voorschriften en veiligheidsnormen, inclusief de juiste kabeldikte en stekker. Het gebruik van niet geschikte Kabels en/of Adapters kan een storing of brand veroorzaken. Wetgeving voor Elektrische apparatuur en Materiaalveiligheid verbied het gebruik van UL of CSA -gecertificeerde Kabels (met UL/CSA in de code) voor elke andere toepassing dan de door Supermicro hiervoor beoogde Producten.

Appendix C:

System Specifications

Processors

Intel® Core™ Ultra 9/7/5 Processors

Single Socket V1 (LGA-1851) supported, up to 125 W TDP

Chipset

Intel W880

BIOS

AMI 32 MB

Memory

Four DDR5, ECC/Non-ECC UDIMM slots, up to 192 GB of memory with speeds of up to 5600 MT/s (1DPC)

Storage Drives

Internal drive bays: Two 3.5" drive bays and six 2.5" drive bays

Two M.2 M-Key NVMe slots (one Gen5 from the CPU, 2280; one Gen4 from PCH supports 2280, 22110)

One SlimSAS x8 connector supports two optional PCIe Gen4 NVMe SSDs

PCI Expansion Slots

Two PCIe 5.0 x16 (16/NA or 8/8)

One PCIe 4.0 x4 from the CPU

Input/Output

Front:

One USB 3.2 Gen 2 port (20 Gb, Type-C)

Two USB 3.2 Gen 1 ports (5 Gb, Type-A)

One audio jack

Rear:

One DisplayPort 2.1

One HDMI 2.1

One Thunderbolt 4 port (40 Gb, Type-C)

Three USB 3.2 Gen 2x1 ports (10 Gb, Type-A)

One USB 3.2 Gen 2x2 port (20 Gb, Type-C)

One Intel Ethernet i219-LM (1 GbE LAN) (for AMT/vPro)

One Intel Ethernet i226-LM (2.5 GbE LAN port)

One HD Audio 7.1 channel connector with SPDIF optical

Motherboard

X14SAE; 12" x 9.6" (30.5 x 24.4 cm)

Chassis

CSE-GS3A, Mid-tower, (DxWxH) 430 x 205 x 450 mm

System Cooling

One 120-mm rear exhaust fan

Three 120-mm front cooling fans

Power Supply

1000 W Multi-Output 80Plus Gold power supply

Operating Environment

Operating Temperature: 10°C ~ 35°C (50°F ~ 95°F)

Non-operating Temperature: -40°C to 60°C (-40°F to 140°F)

Operating Relative Humidity: 8% to 90% (non-condensing)

Non-operating Relative Humidity: 5% to 95% (non-condensing)

Regulatory Compliance

FCC, ICES, CE, UKCA, VCCI, RCM, NRTL, CB

Certified Safety Models

GS3A-10; GS3A-S10X14

Applied Directives, Standards**Directives:**

EMC/EMI: 2014/30/EU (EMC Directive)
Electromagnetic Compatibility Regulations 2016
FCC Part 15 Subpart B
ICES-003
VCCI-CISPR 32
AS/NZS CISPR 32
BS/EN55032
BS/EN55035
CISPR 32
CISPR 35
BS/EN 61000-3-2
BS/EN 61000-3-3
BS/EN 61000-4-2
EN/BS 61000-4-3
EN/BS 61000-4-4
EN/BS 61000-4-5
EN/BS 61000-4-6
EN/BS 61000-4-8
EN/BS 61000-4-11

Environment:

Delegated Directive (EU) 2015/863
Directive 2011/65/EU (RoHS)
REACH Regulation EC 1907/2006
WEEE Directive 2012/19/EU
California Proposition 65

Product Safety:

2014/35/EU (LVD Directive)
UL/CSA 62368-1 (USA and Canada)
Electrical Equipment (Safety) Regulations 2016
IEC/BS/EN 62368-1

Perchlorate Warning

California Best Management Practices Regulations for Perchlorate Materials: This Perchlorate warning applies only to products containing CR (Manganese Dioxide) Lithium coin cells. Perchlorate Material-special handling may apply. See

<https://www.dtsc.ca.gov/hazardouswaste/perchlorate>

この装置は、クラスBの機械です。この装置は、住宅環境で使用することを目的としていますが、この装置がラジオやテレビジョン受信機に近接使用されると、受信障害を引き起こすことがあります。

取扱説明書に従って正しい取り扱いをしてください。

VCCI – B